

# Wind energy & power

- Energy : resource (wind origin and potential)
- Power : electricity generation through turbines

# Wind Energy – 1. Resources

# Learning objectives

- explain the different active forces that cause 'wind'  
(pressure gradient; Coriolis; centrifugal; surface roughness)
- describe the wind speed (probability) distribution at an exploitation site

# Origin & gross potential of wind power

Large-scale movement of air mass in the atmosphere, created primarily by differential solar heating of the Earth's atmosphere;

= **secondary solar** energy

~**42%** of the incident **solar** energy on Earth's surface (=itself 51% of extra-terrestrial solar radiation ( $5.5 \cdot 10^{24}$  J/yr)) is converted to convection, or **kinetic wind energy**.

~**30%** of this is available in a **1 km layer** above ground level.

Suppose we would harness **1%** of this energy on land areas (**30%** of the planet's surface).

(We'll see that efficiency is ~**40%**, and the load factor ~**20%**.)

=> plugging in all those numbers give a power potential of :

**0.42\*0.3\*0.3\*0.01\*0.40\*0.20\*51%** of  $5.5 \cdot 10^{24}$  J/yr =  $8.5 \cdot 10^{19}$  J/yr = 23600 TWh<sub>el</sub>/yr

~ of the same order as the current world electricity consumption (30'000 TWh<sub>el</sub>)

Rem: wind electricity production in 2025 was ~3000 TWh<sub>el</sub> ! (1300 GW installed)

# Origin : $\Delta T \Rightarrow \Delta P$

The sunrays cover a greater area at the **poles** than at the **equator**  
→ lower energy density is received at ground level at the poles ⇒ lower heating ⇒ lower T

This generates pressure gradients that set air in motion.

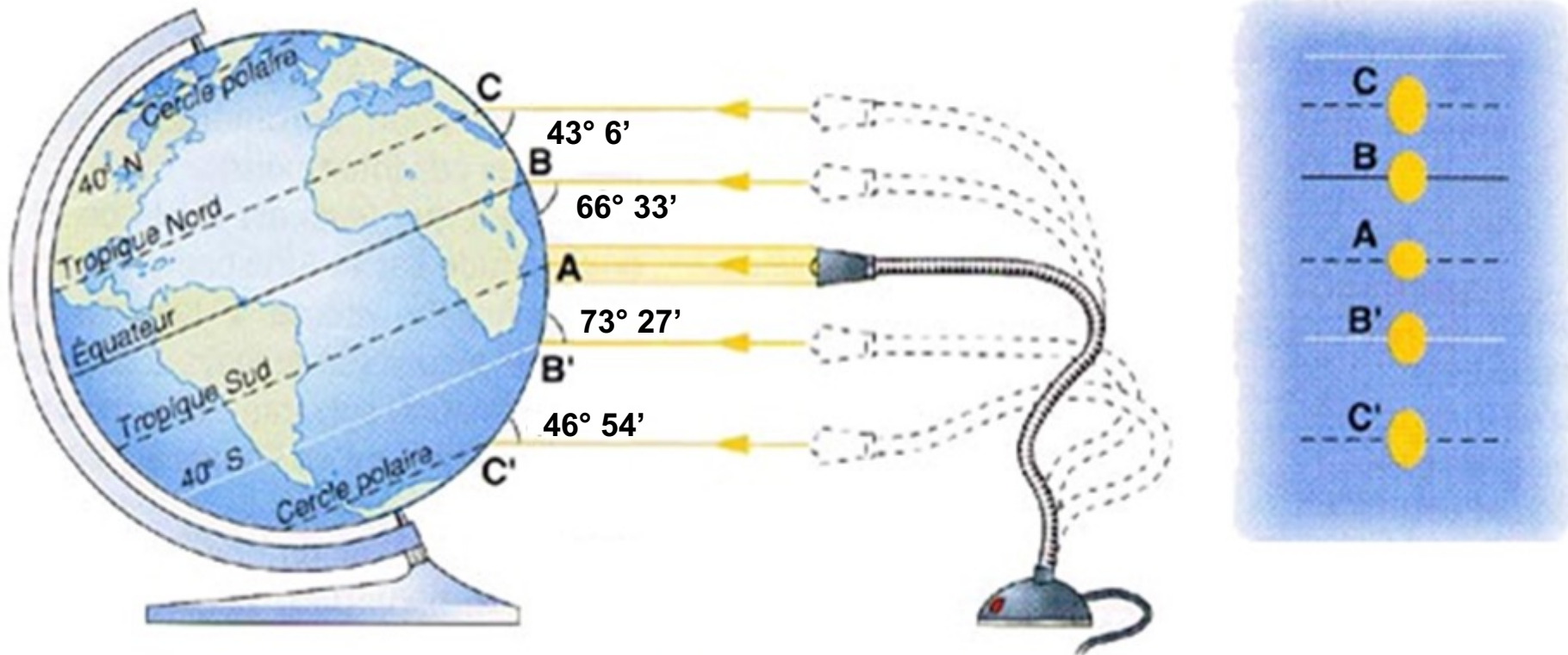

# 1<sup>st</sup> approximation model of the air circulation

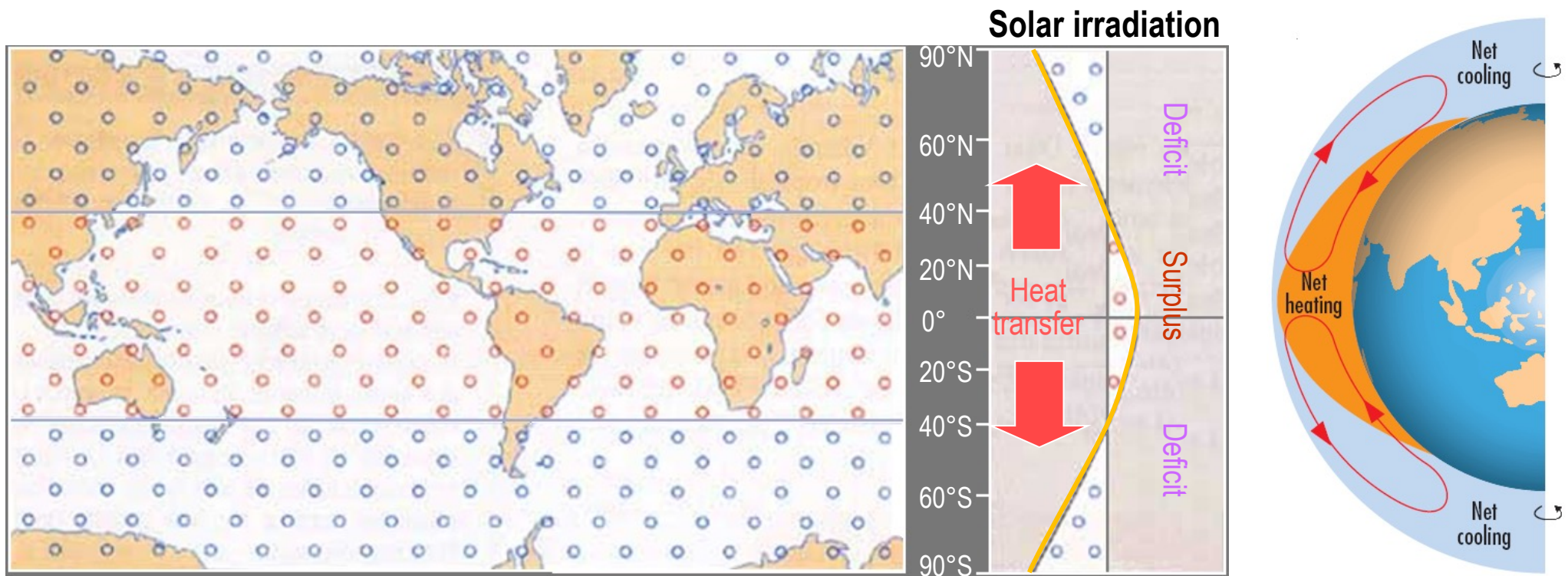

<http://www.youtube.com/watch?v=DHrapzHPCSA&feature=related>

... oversimplistic, because it doesn't take into account the effect of the **terrestrial rotation** in particular

# Terrestrial rotation effect

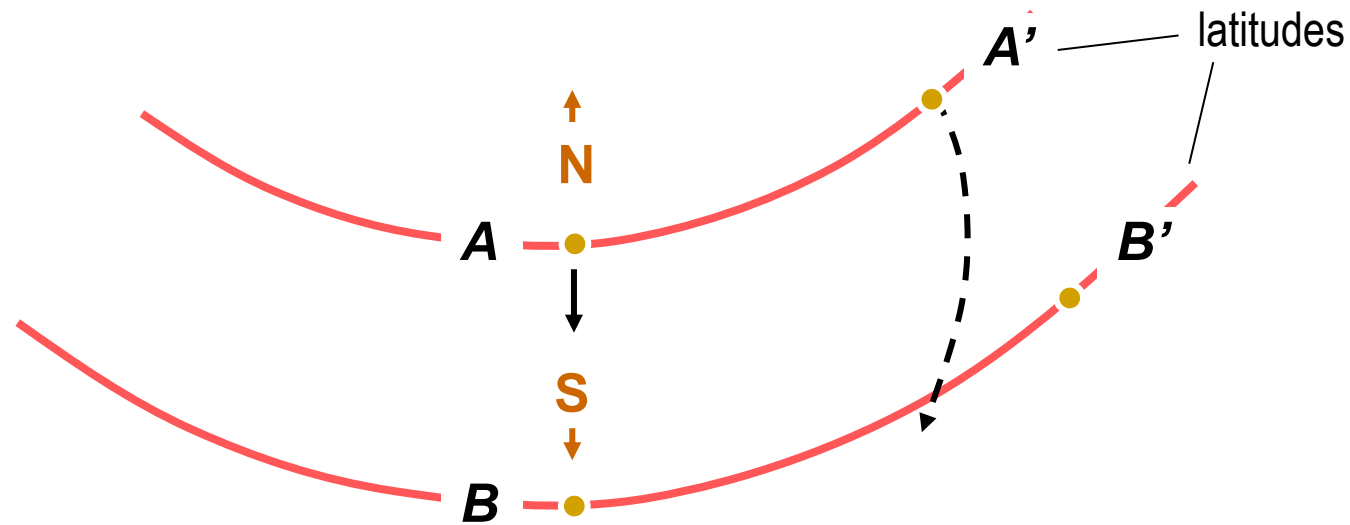

With air moving south from *A* to *B*, the speed of the air will remain constant with respect to the ground (ignoring air friction), but the direction will change, because of the earth's rotation under this air.

# Reminder of rotation axes definition

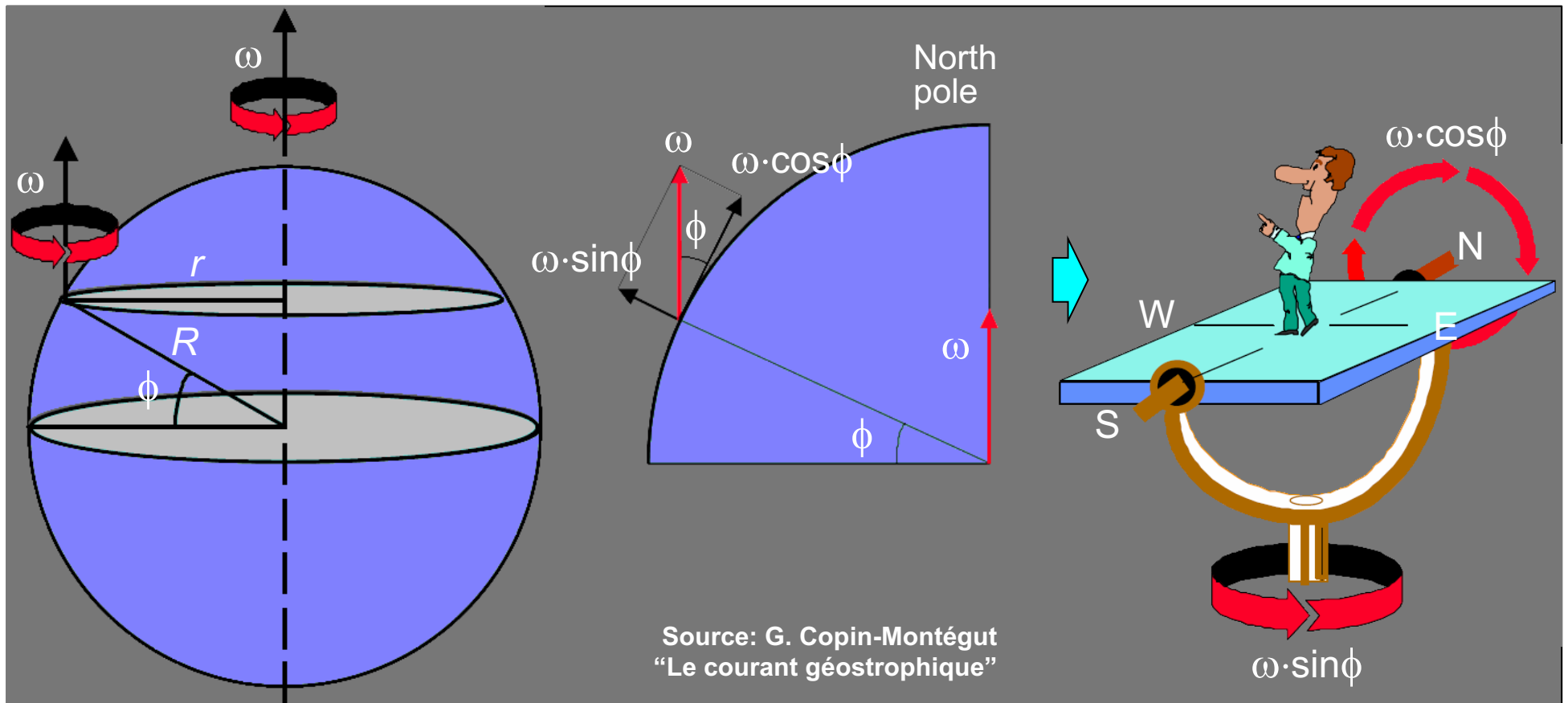

# Terrestrial rotation

Point P rotates on itself with the terrestrial angular speed  $\omega$ ; viewed from P, it behaves like a center of rotation itself, around which its environment turns with the same angular speed.

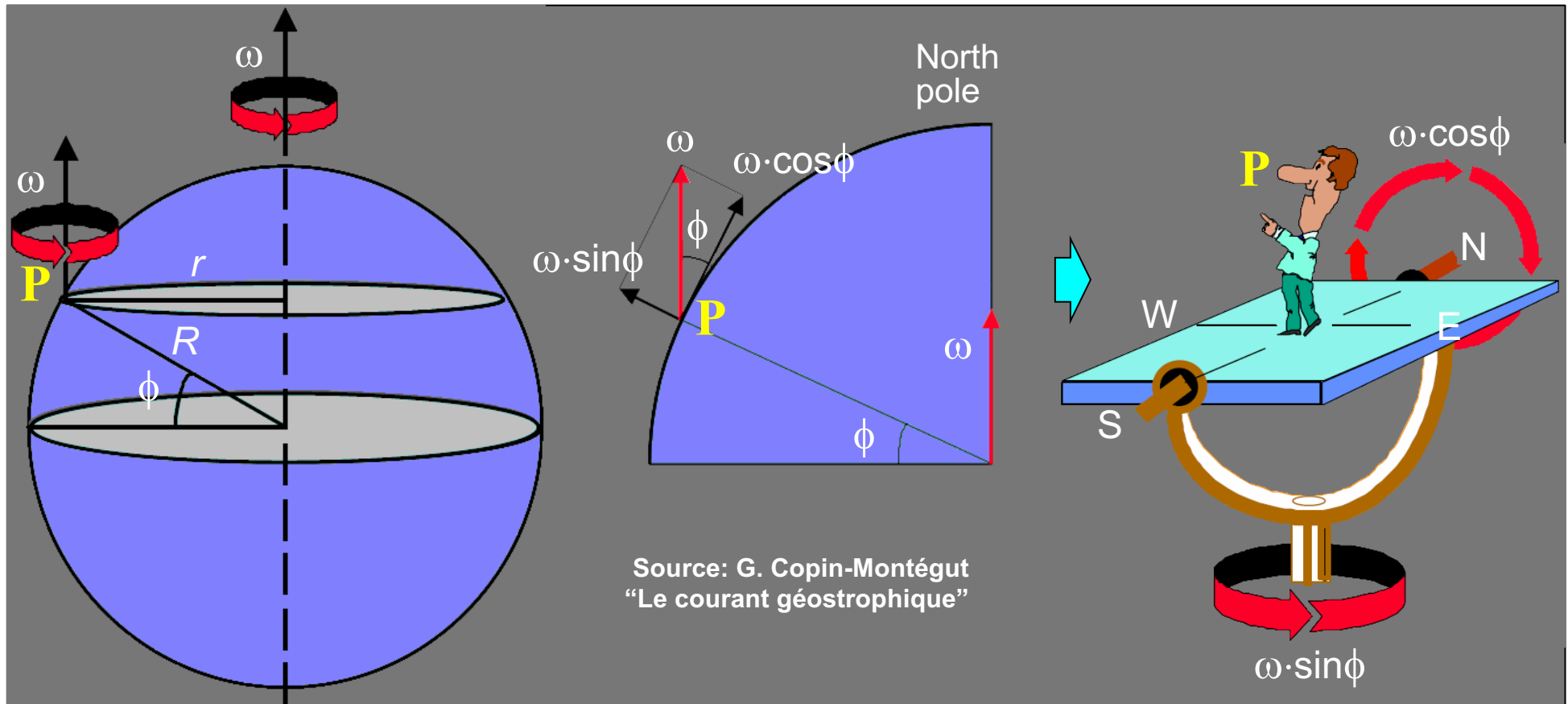

linear speed of object or observer  
at point P at latitude  $\phi$ :

$$v = \omega \cdot r = \omega \cdot R \cdot \cos \phi$$

For an observer in point P (at latitude  $\phi$ ), the observed rotation will be seen as a combination of

- the rotation around a **local vertical** axis ( $\omega \cdot \sin \phi$ ), and
- the rotation around a **local horizontal** north-south axis ( $\omega \cdot \cos \phi$ )

# Coriolis force: example

(horizontal displacement  $v$  in N-S direction)

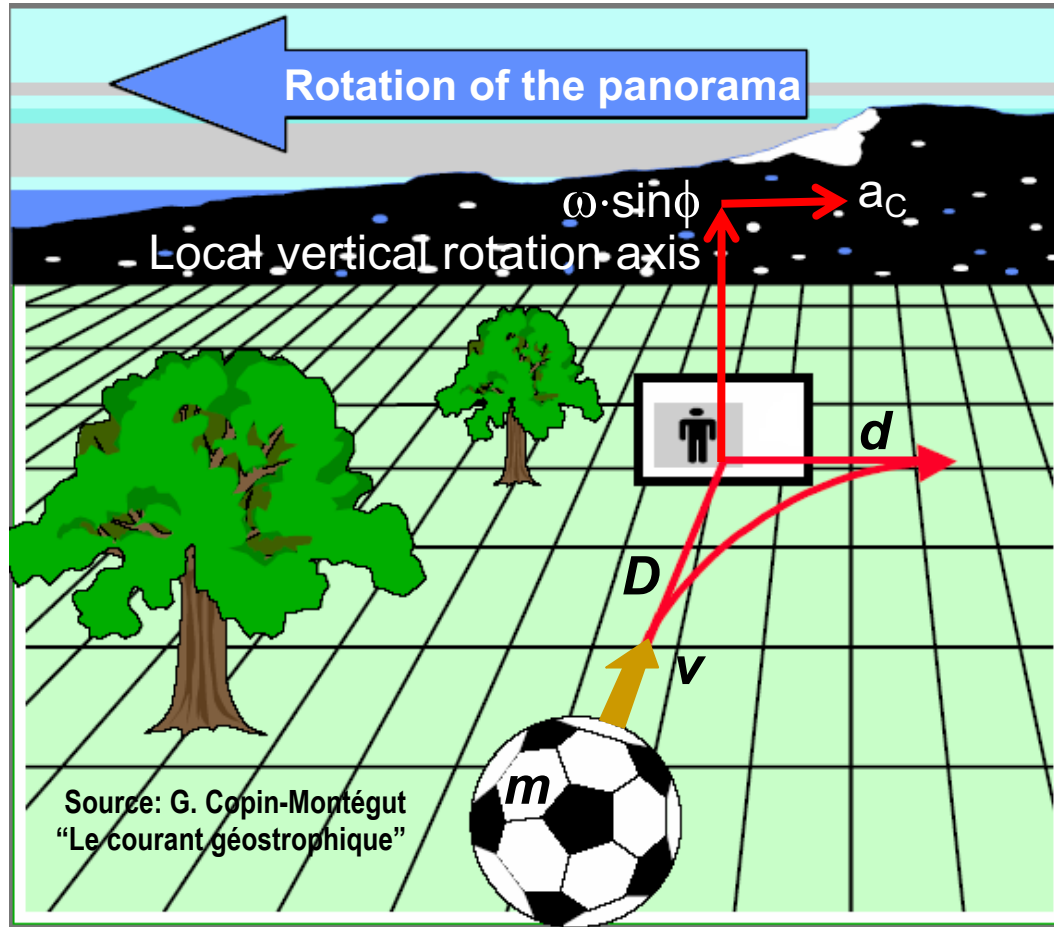

**Coriolis force:**

$$F_C = m \cdot 2v \cdot \omega \cdot \sin \phi$$

1. Travel time of the ball from shooter to target (north  $\rightarrow$  south):  $\Delta t = D/v$
2. Deviation  $d$  of the ball from target:  
=  $\Delta t$  times Earth's rotational speed (the panorama rotates around the **local vertical axis**  $\omega \sin \phi$  in this case)

$$d = D \cdot \omega \cdot \sin \phi \cdot \Delta t$$

$$= v \cdot \omega \cdot \sin \phi \cdot \Delta t^2$$

3. Introducing acceleration  $a$ :

$$d = \int_0^{\Delta t} v \, dt = \int_0^{\Delta t} a \cdot t \, dt = a \cdot \Delta t^2 / 2$$

4. Combining 2. and 3. we have:

$$\Rightarrow d = v \omega \sin \phi \Delta t^2 = \frac{1}{2} a_c \Delta t^2$$



5. **Coriolis** acceleration:

$$a_C = 2v \cdot \omega \cdot \sin \phi$$

! In 3-D, the Coriolis acceleration  $a_C$  is in fact a **vector product**  $\mathbf{v} \times \boldsymbol{\omega}$  (maximal when both vectors are perpendicular ( $\sin=1$ ))

# General outcome of the Coriolis effect:

**deviation to the right of the trajectory in the Northern hemisphere**

in other words:  
the Coriolis force (or acceleration) acts at an angle  $90^\circ$  to the right of the trajectory

**deviation to the left of the trajectory in the Southern hemisphere**

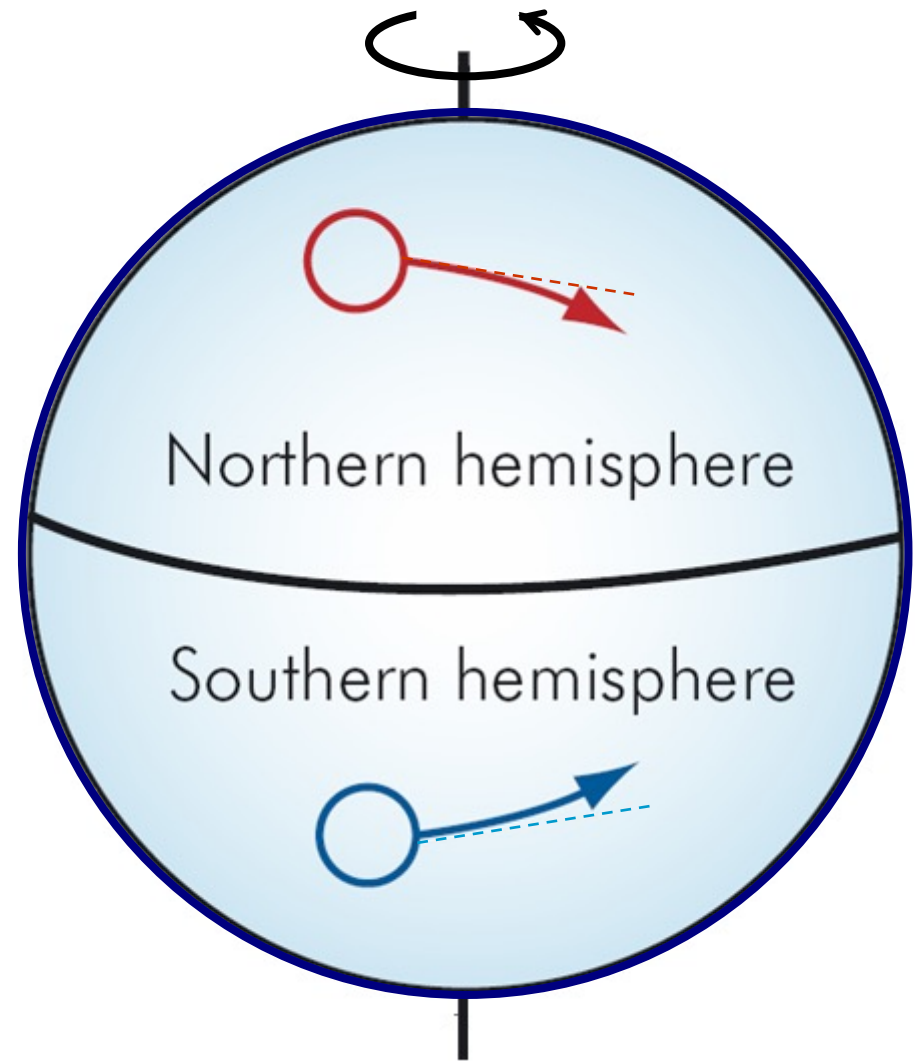

# The Coriolis effect breaks up global air circulation

<http://www.youtube.com/watch?v=DHrapzHPCSA&feature=related>

Source: Wichita.edu  
"Planetary atmospheres"

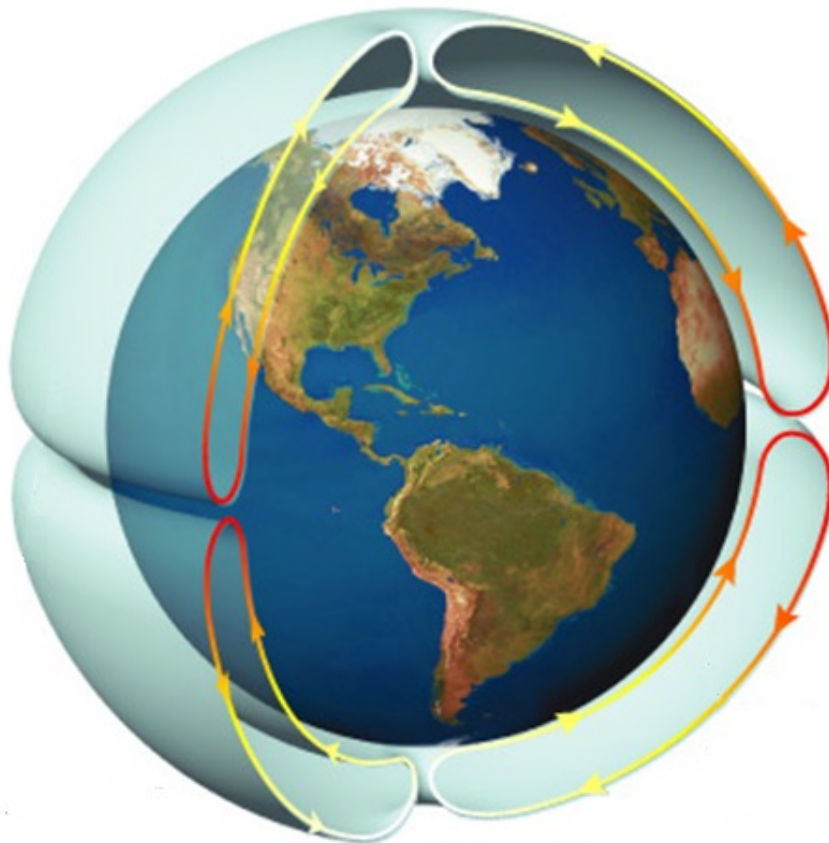

Simplistic global  
circulation model

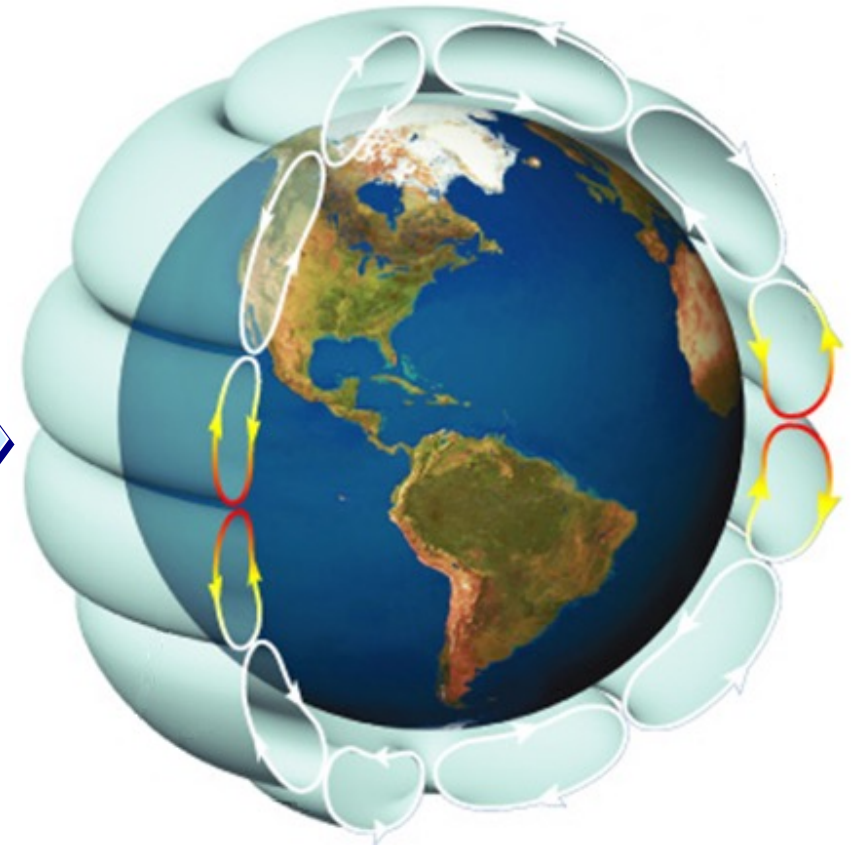

More realistic global  
circulation model  
=> 'convection cells'

# Global circulation model

The terrestrial rotation (surface speed 1670 km/h at the equator, decreasing to zero at the poles) influences air circulation such as to create convection cells (3 per hemisphere).

The airflow from the equator to the poles is deflected towards the *east* and the return flow from the poles to the equator is deflected towards the *west*, producing the so-called *Trade Winds* (“*alizés*”).

1. Hadley Cells
2. Ferrel Cells
3. Polar Cells

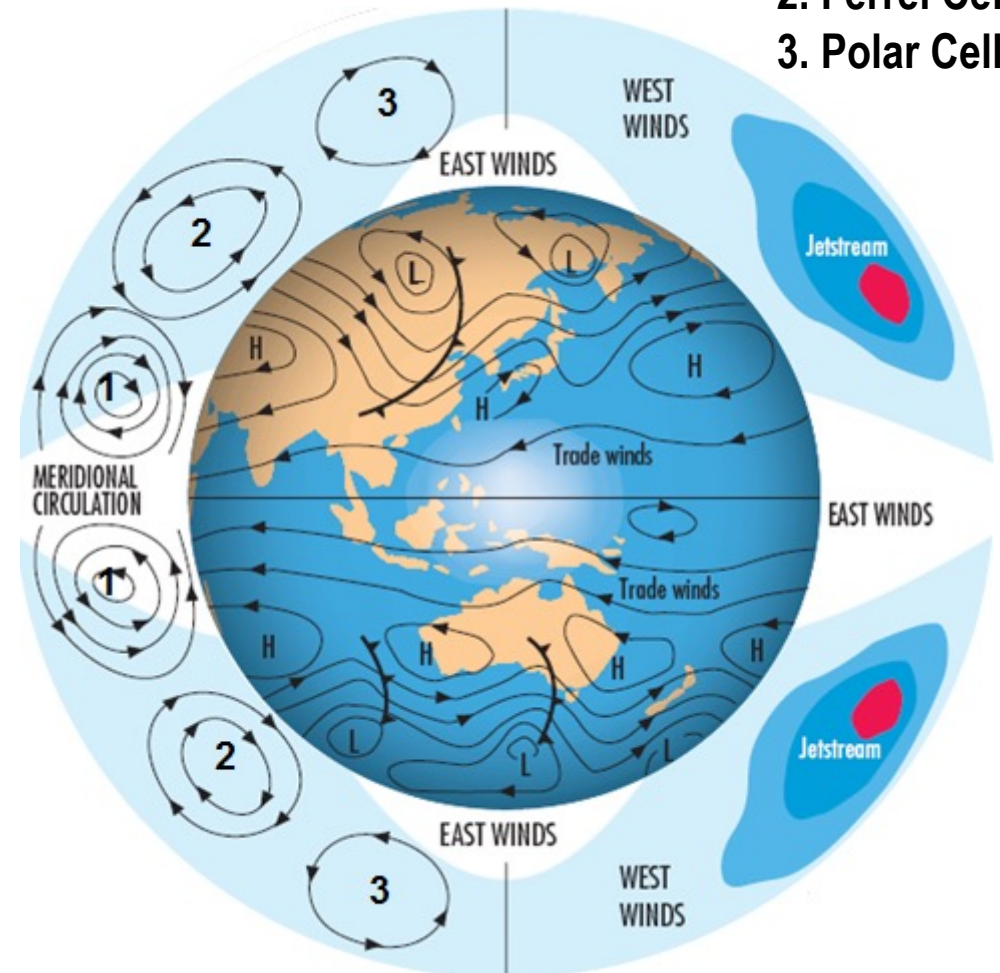

# Wind 'cells' and dominant winds

1. Hadley Cells
2. Ferrel Cells
3. Polar Cells

## Coriolis effect:

- Strong at the poles ( $\sin\phi \approx 1$ )
- Weak at the equator ( $\sin\phi \approx 0$ )

## Dominant winds

Latitude	90-60°N	60-30°N	30-0°N
Direction	NE	SW	NE
Latitude	0-30°S	30-60°S	60-90°S
Direction	SE	NW	SE

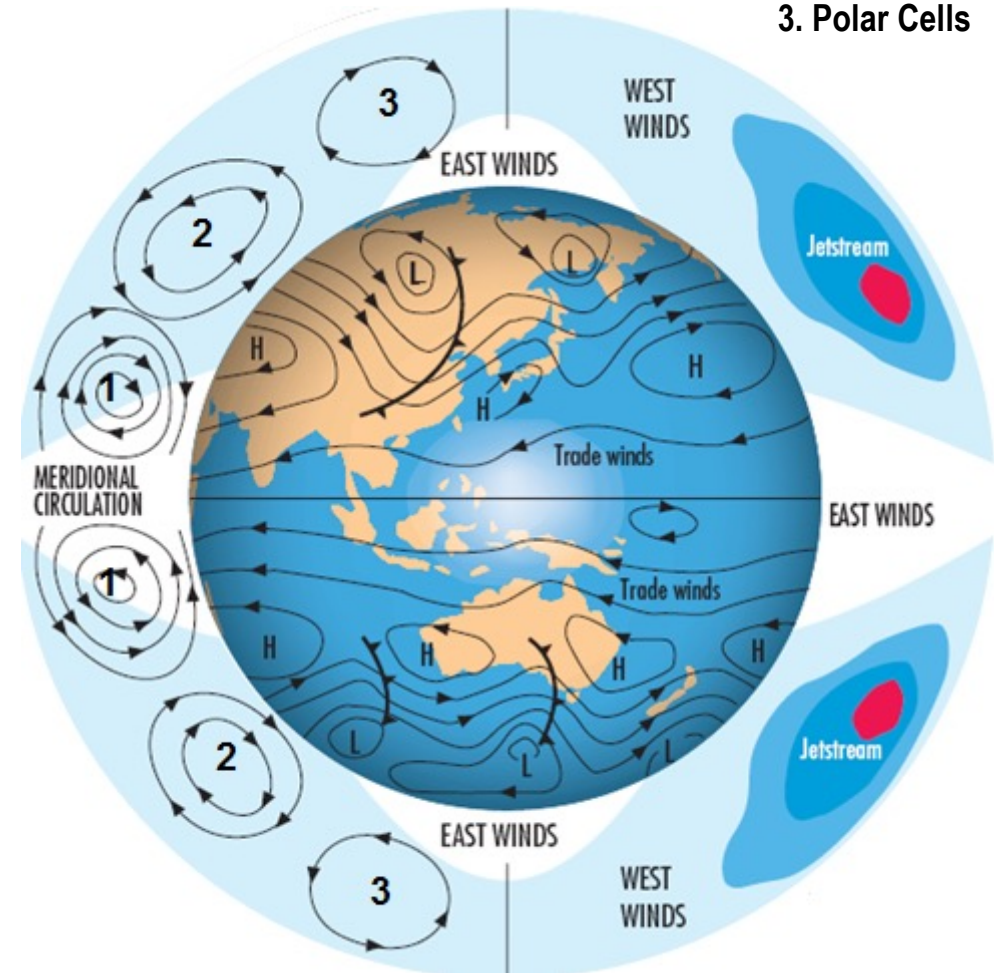

# 'Jet streams'

The most regular and persistent winds are found at an altitude of  $\approx 10$  km ("jet streams") (cf. the circumterrestrial flight of the hot air balloon "Breitling Orbiter 3" exploited these winds).

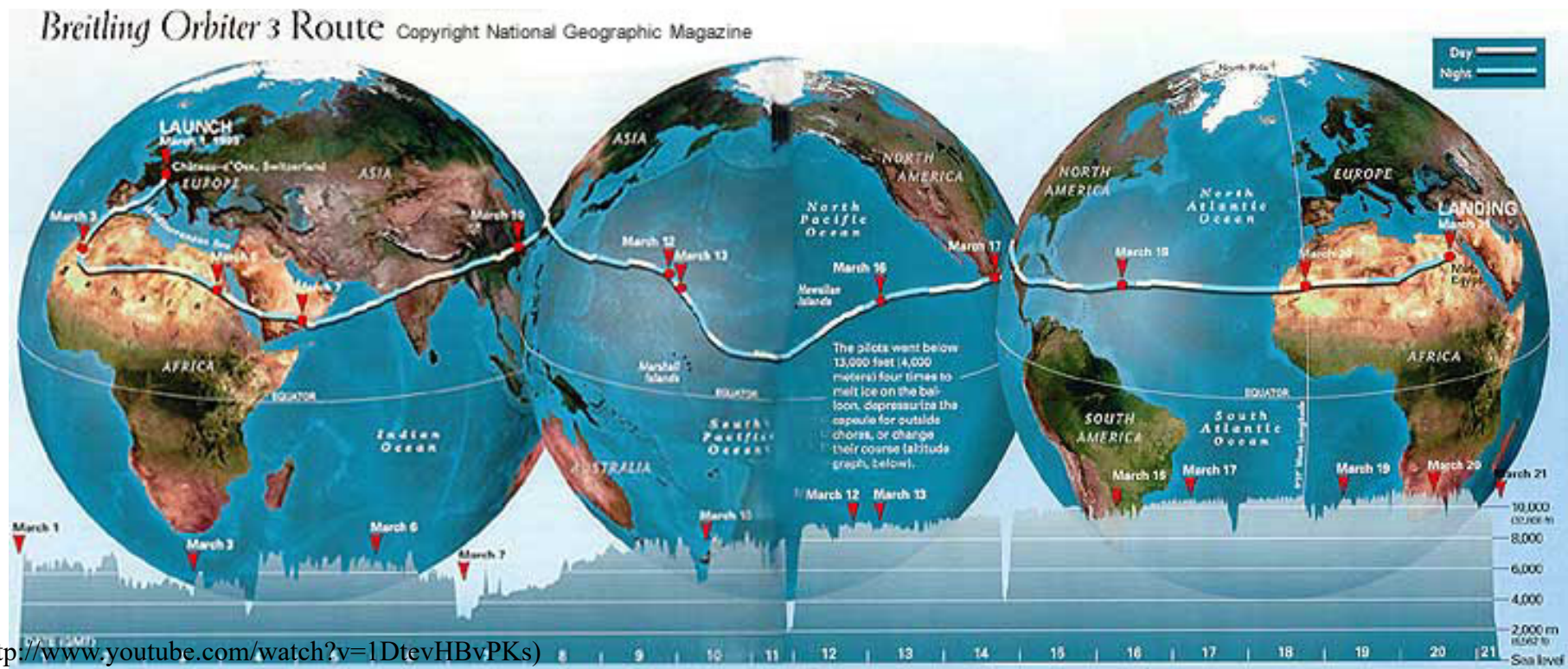
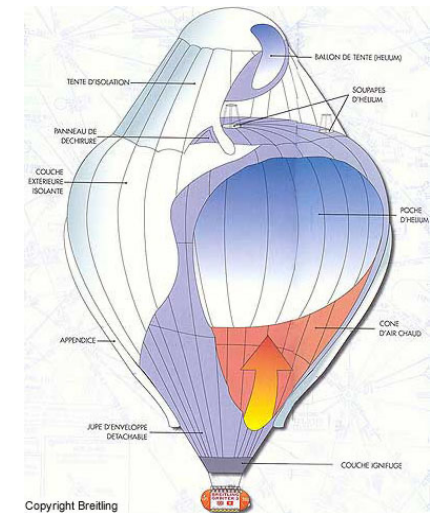

(<http://www.youtube.com/watch?v=1DtevHBvPKs>)

# Convection cells → high & low pressure zones

The areas of the globe where air is descending are zones of high pressure.  
Where air is ascending, low-pressure zones are formed.

This horizontal pressure gradient drives the flow of air from high to low pressure  
→ this determines the acceleration and initial direction of the wind motion.

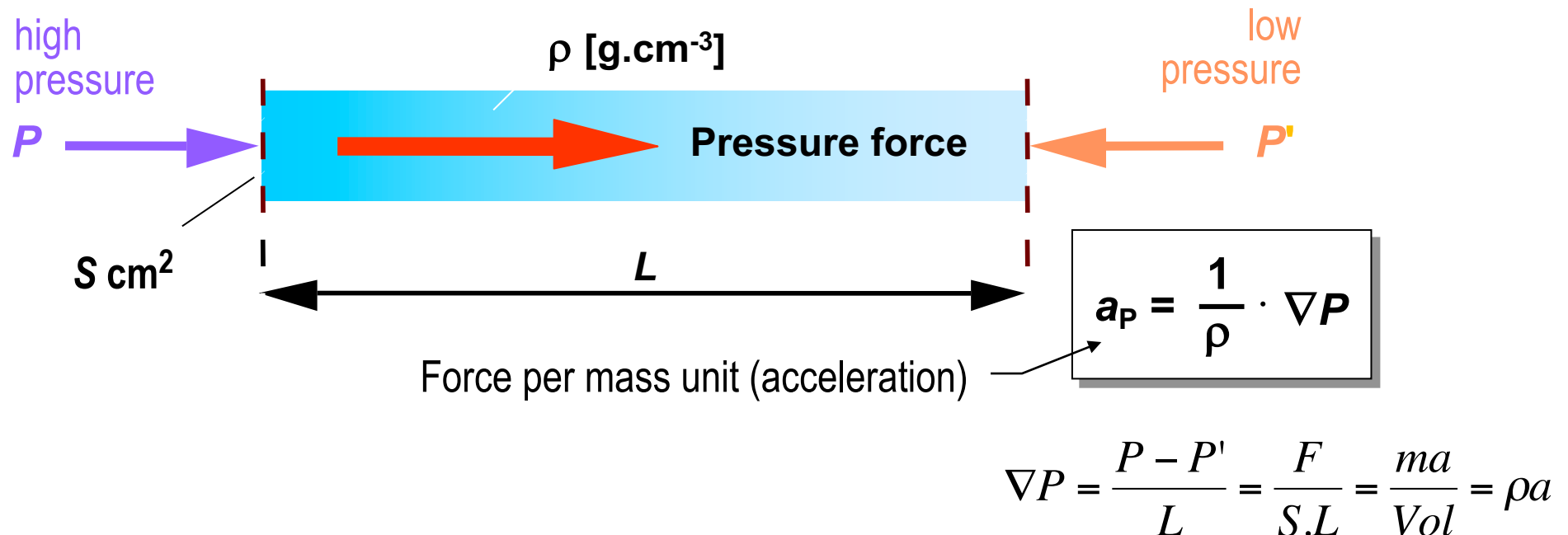

# Pressure force / Coriolis force balance

As soon as wind motion is established, the deflective Coriolis force is activated.

In equilibrium, for straight isobars, the **Coriolis** force balances the **pressure gradient** force and the flow becomes parallel to the isobars

$$a_c = 2v \cdot \omega \cdot \sin \phi \quad a_p = \frac{1}{\rho} \nabla P$$

Stationary case (force equilibrium) :

$$v_g = \frac{\nabla P}{2 \cdot \rho \cdot \omega \cdot \sin \phi}$$

**geostrophic wind**

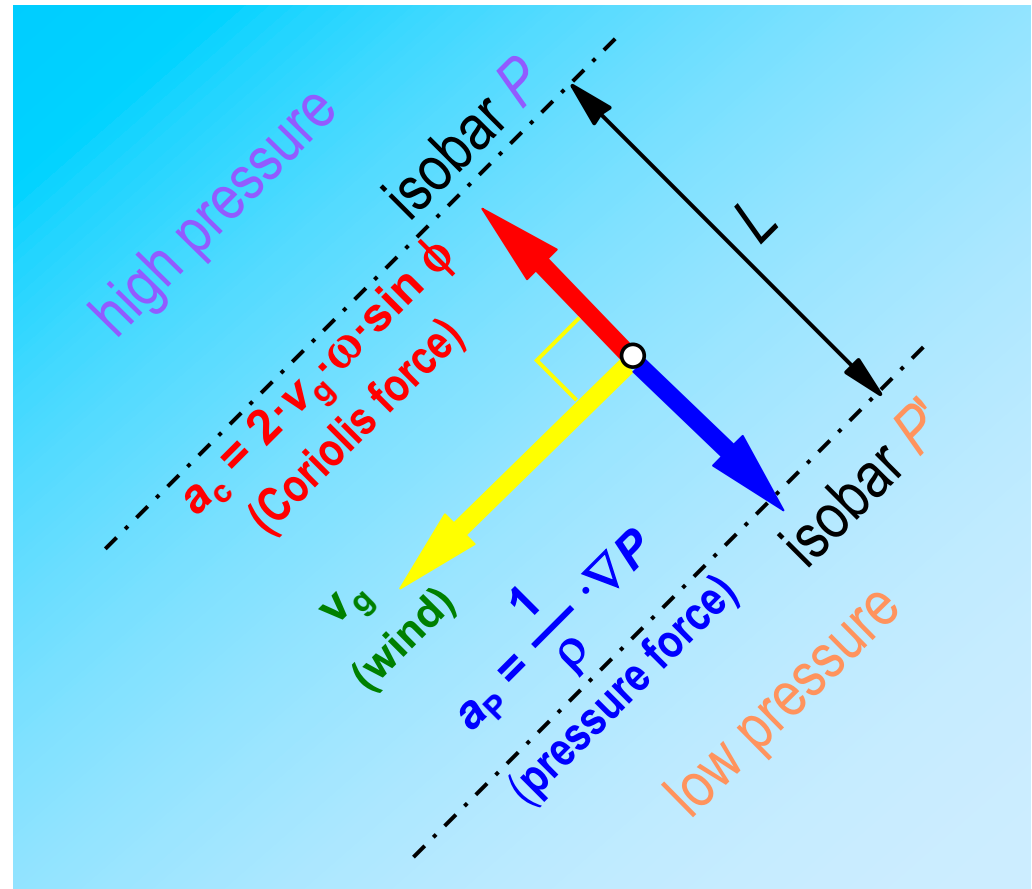

Remember that the Coriolis force (or acceleration) acts at an angle 90° to the right of the trajectory

# → Geostrophic wind

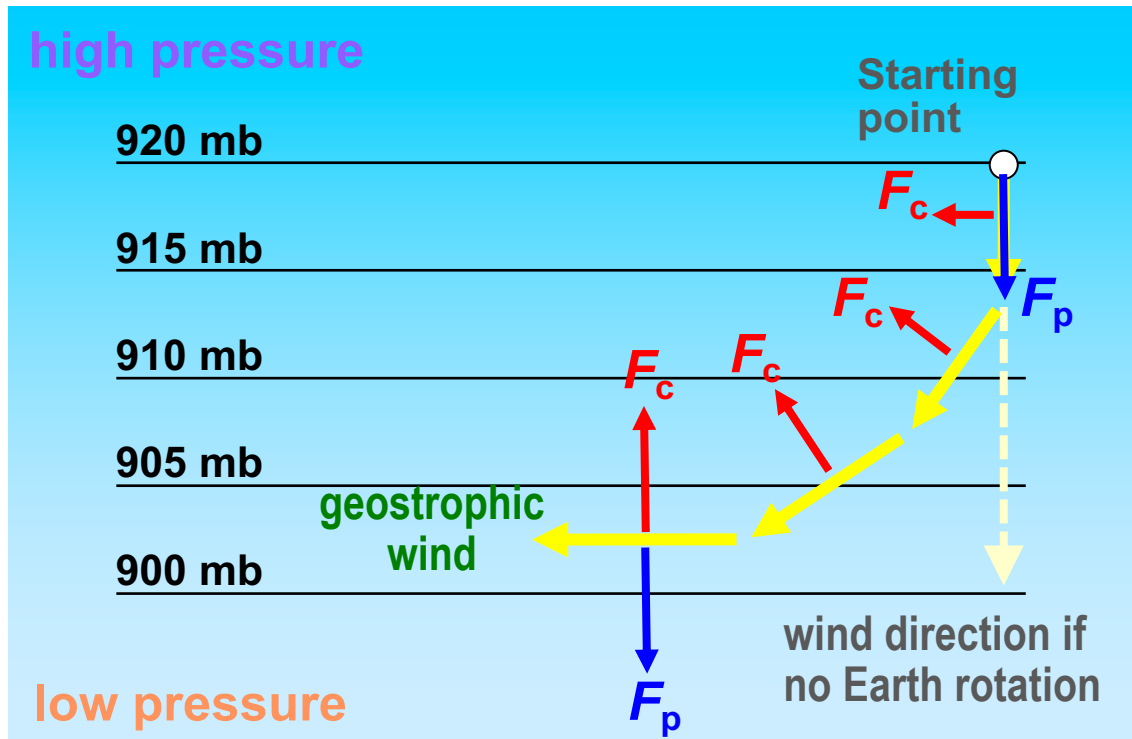

In this model of wind flow in the Northern Hemisphere, wind begins as a flow of air perpendicular to the isobars under the primary influence of the pressure gradient force ( $F_p$ ); as the movement begins, the Coriolis force ( $F_c$ ) influences the moving air causing it to deflect to the right.

The deflection continues until the pressure gradient and Coriolis forces are opposite and in balance with each other → geostrophic wind

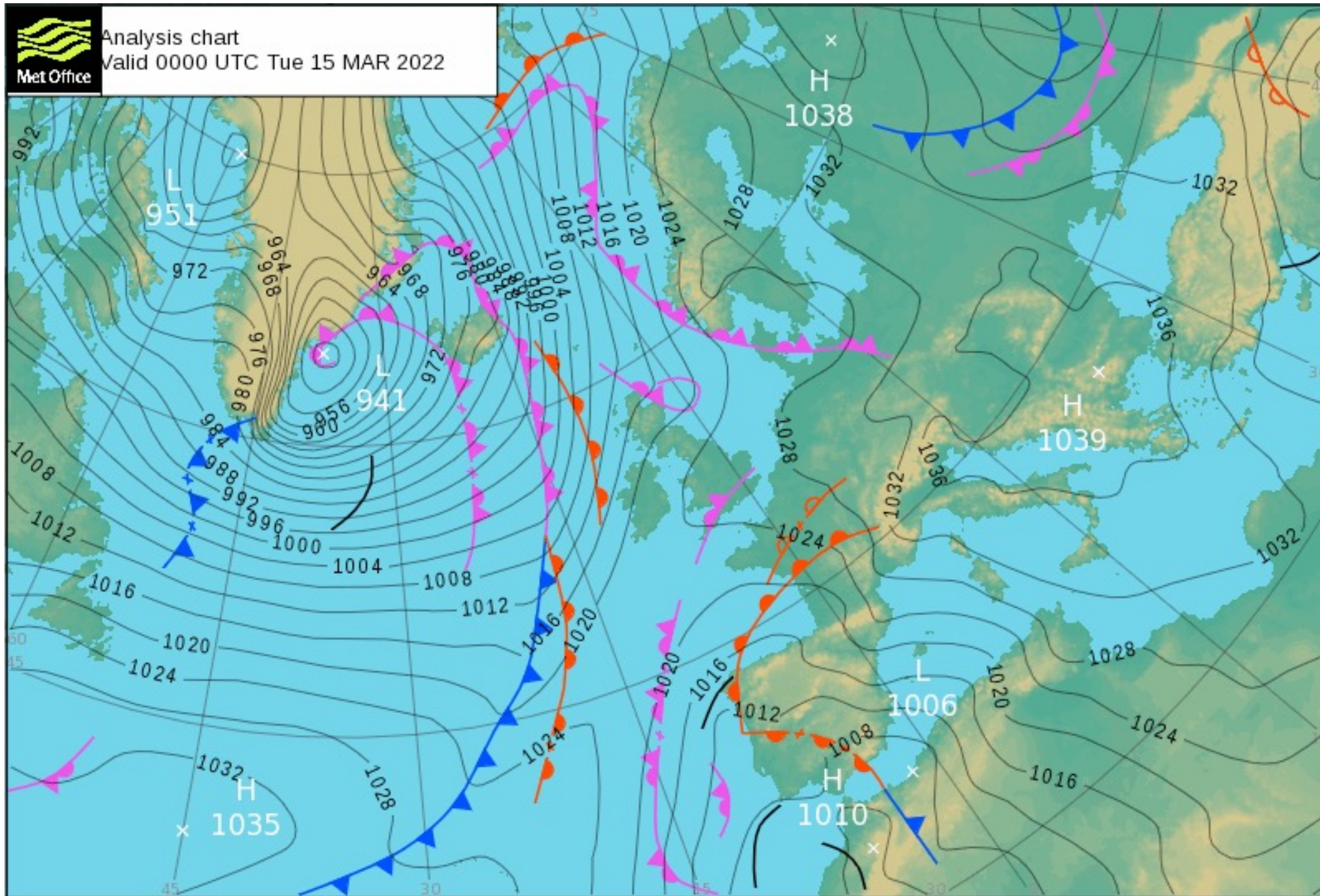

# Numerical example:

Earth's angular speed  $\omega = 1$  rotation per day  $= 2 \cdot \pi / 24$  h  
 $= 6.28 \text{ rad} / (24 \times 3600 \text{ seconds}) = 0.00007272 \text{ rad/s}$

Say we have a pressure difference of 10 mbar over 1000 km distance (cf. the previous map):  
10 mbar = 1000 Pa  
 $\Rightarrow$  the pressure gradient is  $1000 \text{ Pa} / 1000 \text{ km} = 1000 / 1'000'000 \text{ m} = 0.001$

So the geostrophic wind speed, with the formula 
$$v_g = \frac{\nabla P}{2 \cdot \rho \cdot \omega \cdot \sin \phi}$$

equals,

at  $45^\circ$  latitude ( $\phi$ ) and with air density  $\rho$   $1.22 \text{ kg/m}^3$  (sea level):

$$v_g = 0.001 / (2 * 1.22 * 0.00007272 * \sin (45^\circ)) = 8 \text{ m/s}$$

# A 3<sup>rd</sup> force, centrifugal force $F_R$ , adds to the pressure $F_p$ (1<sup>st</sup>) force & Coriolis $F_c$ (2<sup>nd</sup>) force

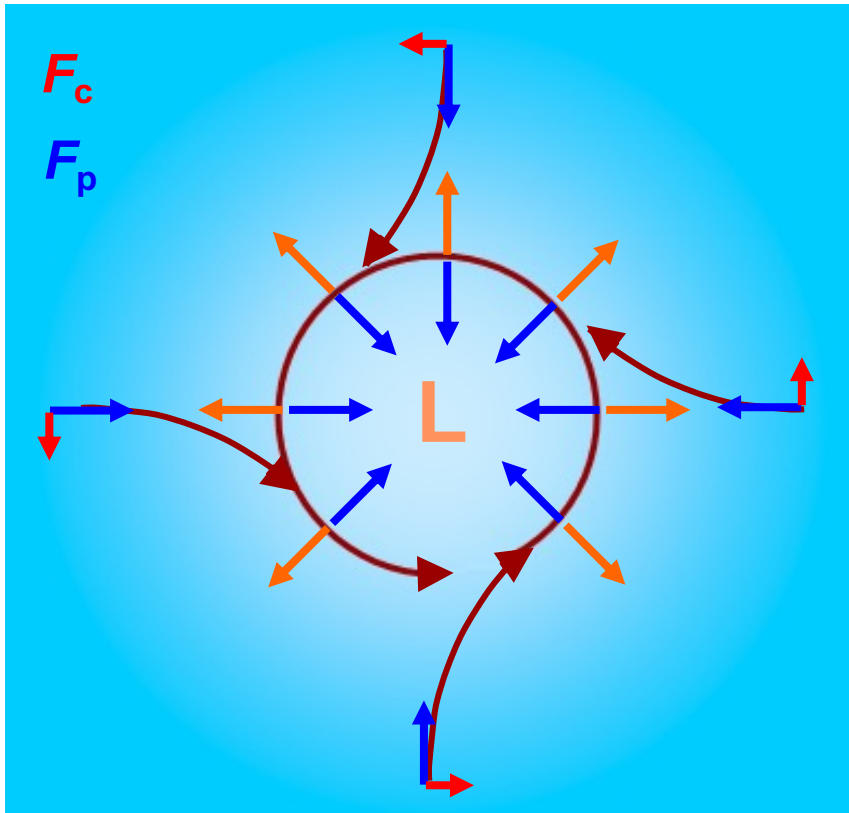

Mostly, isobars are not straight but curved  
→ this causes **centrifugal forces** to be taken into account.

Winds in this case become **gradient winds**

The rotary direction of mid-latitude cyclones (northern hemisphere) is anti-clockwise.

Schematic representation of the air flow around a low-pressure area (cyclonic flow) in the Northern hemisphere

# Gradient wind: 3 force components

$$F_c = F_p - F_R$$

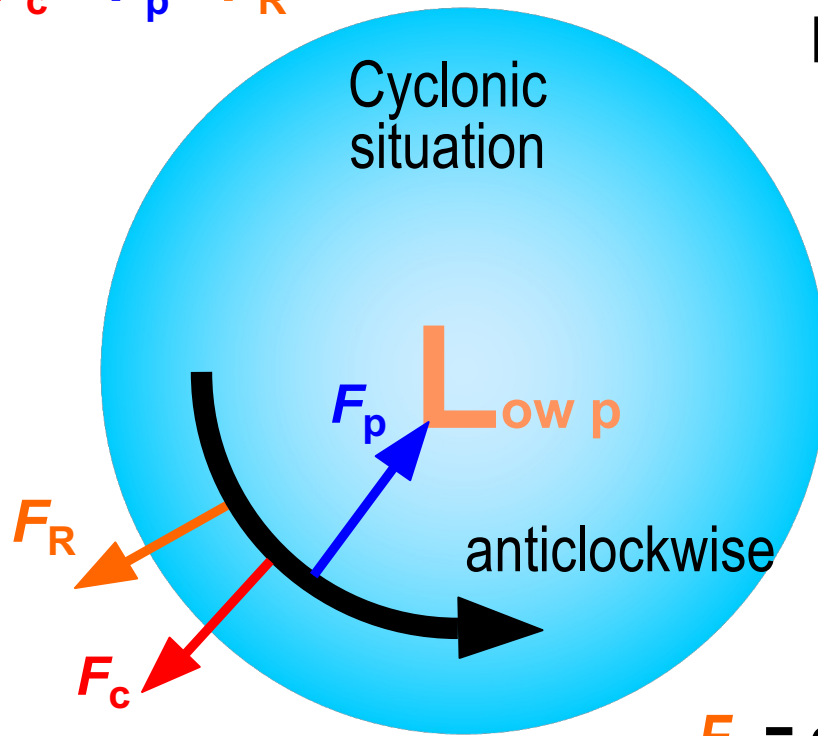

Northern hemisphere

$$F_c = F_p + F_R$$

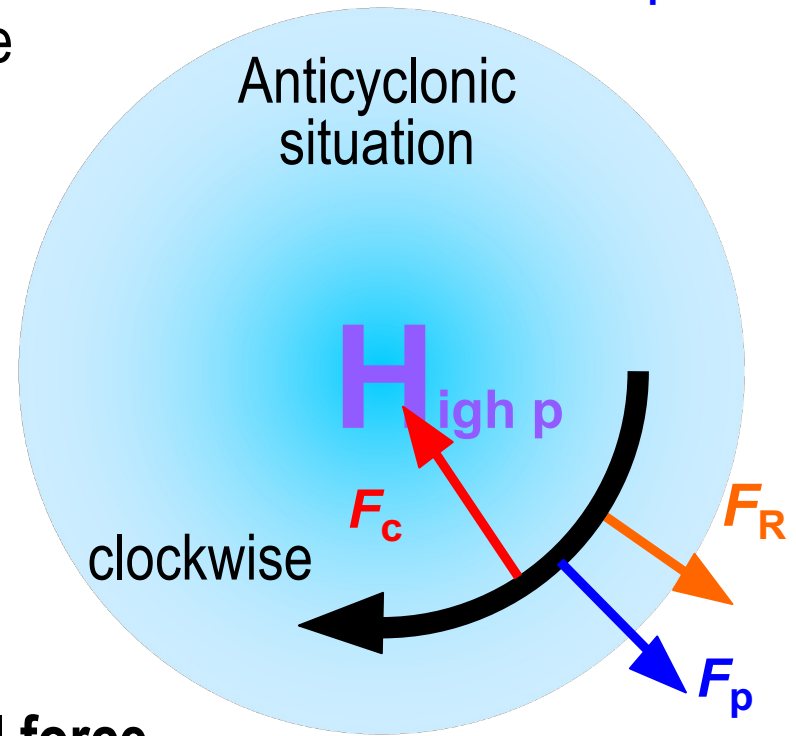

$F_R$  = centrifugal force

# Gradient wind result

$$v_{gradient} = v_{geostrophic} \ominus \frac{v_{gradient}}{2R\omega \sin \phi}$$

$$v_{gradient} = v_{geostrophic} \oplus \frac{v_{gradient}}{2R\omega \sin \phi}$$

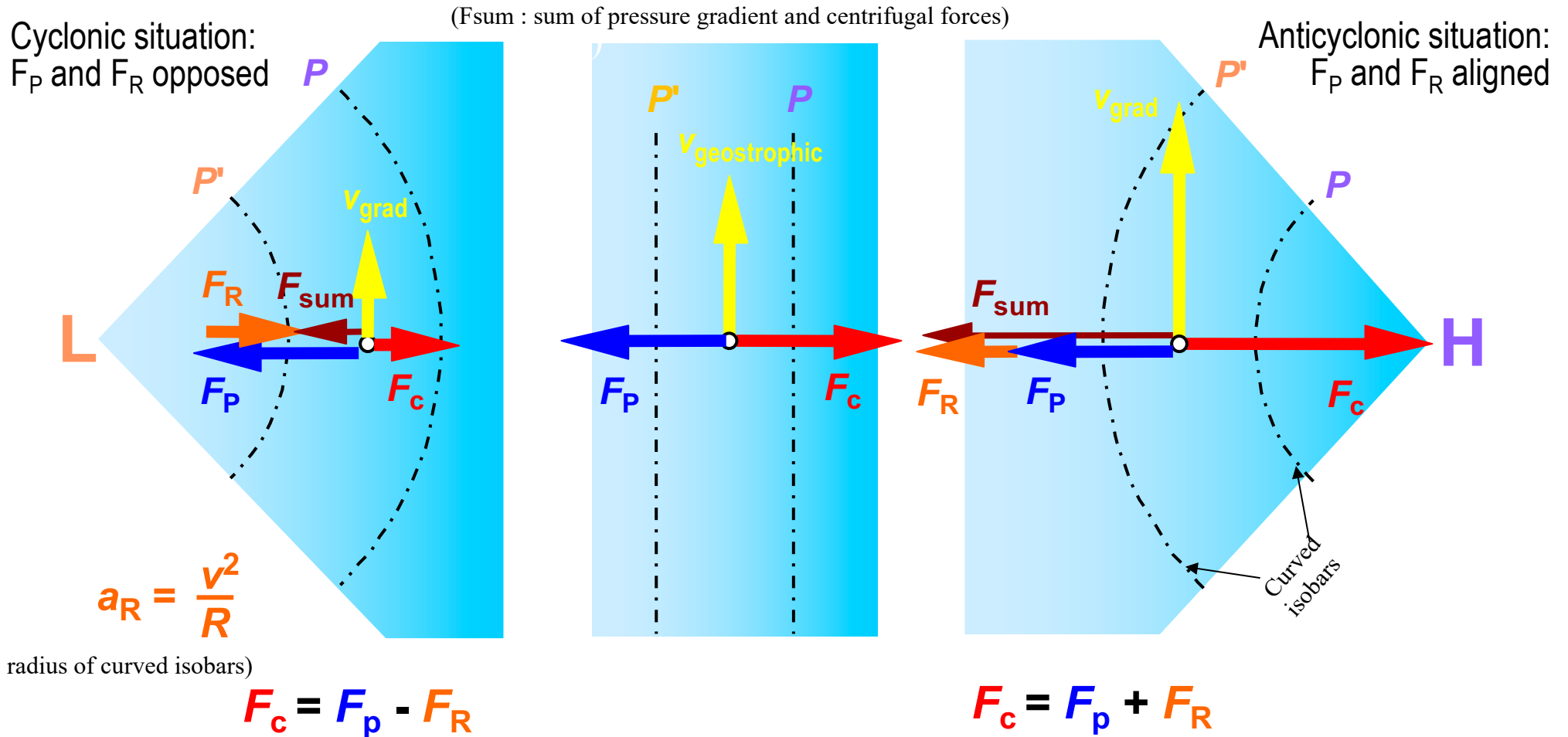

# Earth surface roughness effect

In low altitudes, the wind speed and direction become more and more influenced by frictional forces on the Earth's surface.

This region is known as the *planetary boundary layer*; its height varies from a few 100 m at night to a max of 2 km on the most convective days.

The lower layers of air retard those above them until the shear forces (forces parallel to the ground) are gradually reduced to zero.

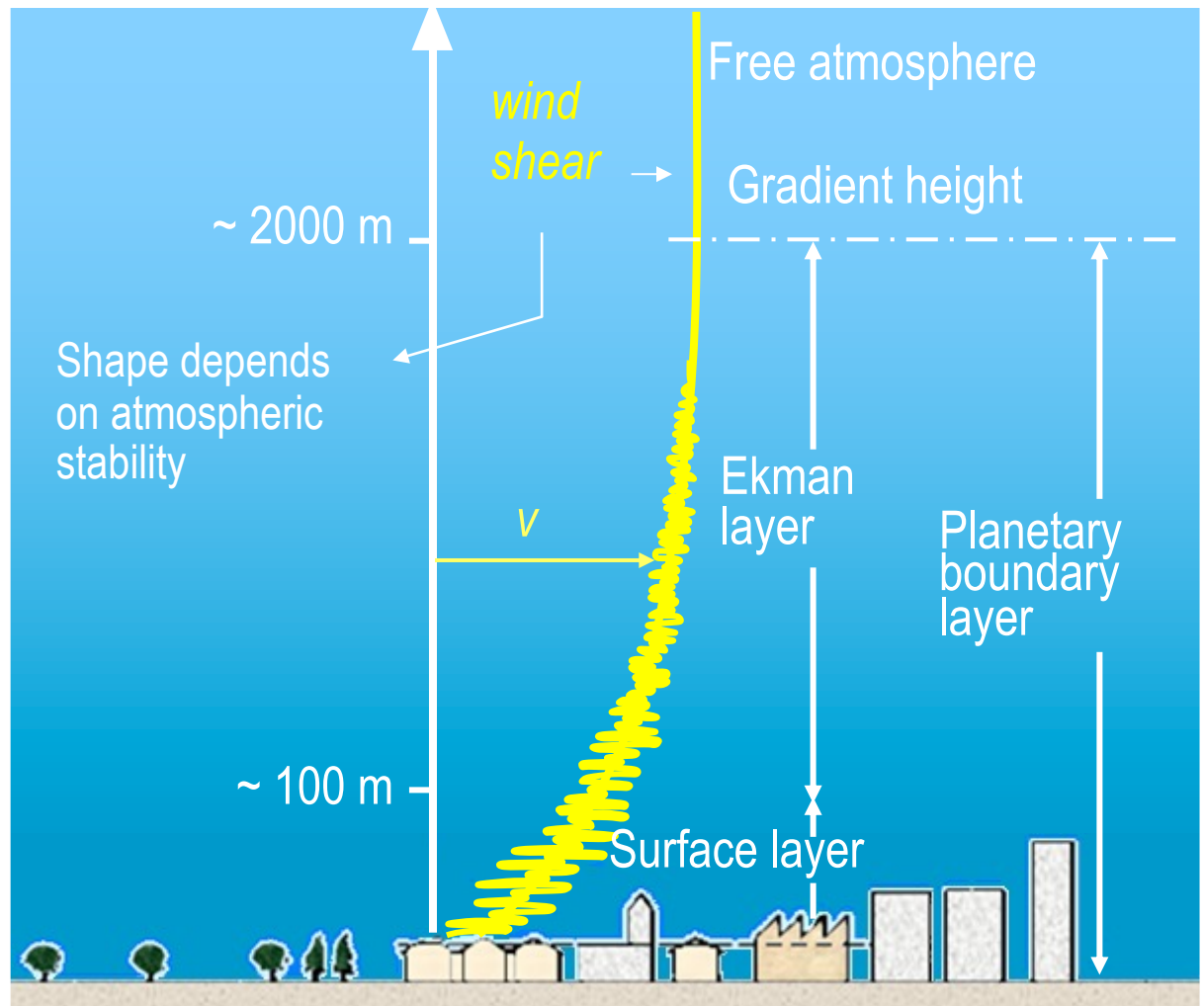

# Representations of the horizontal components of the wind velocity

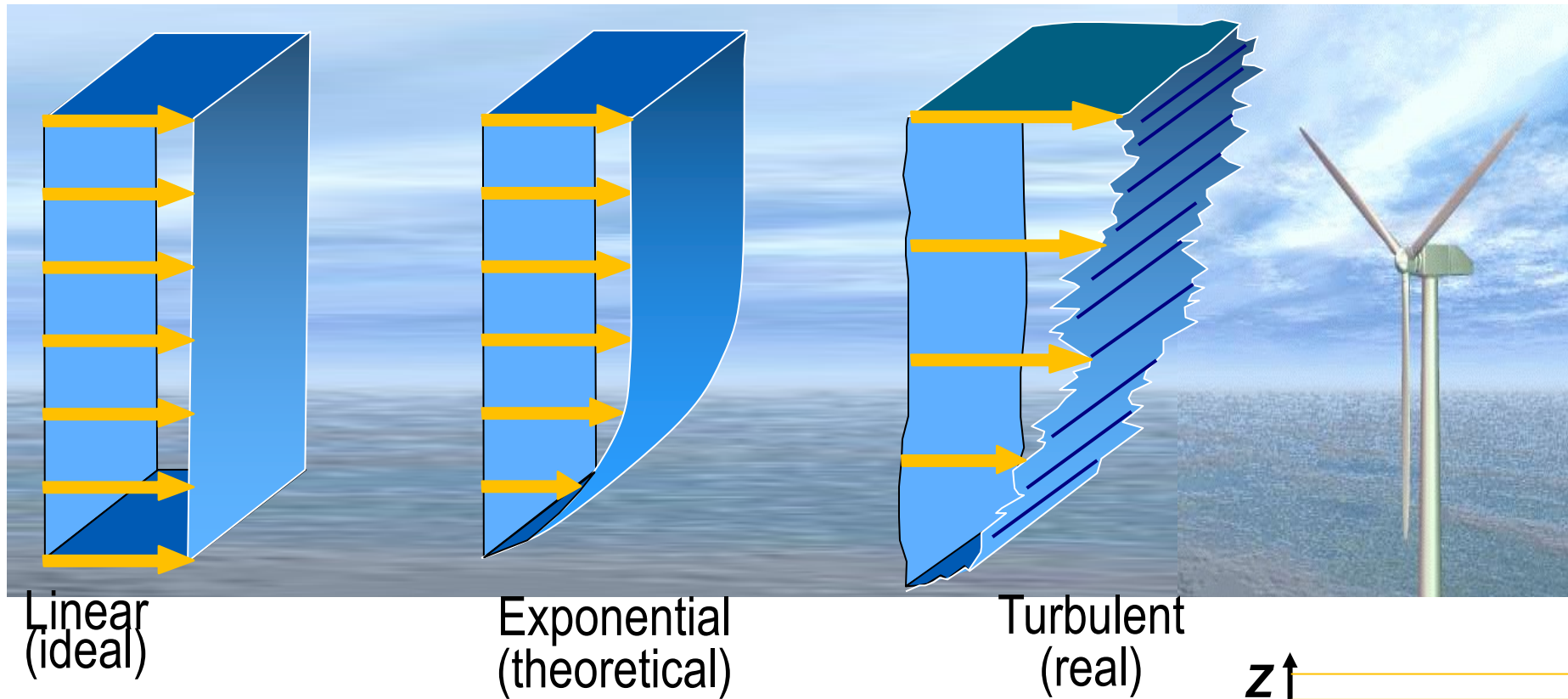

For a neutrally stable atmosphere (= the usual conditions for the higher wind speeds associated with wind turbine operation):

$$v(Z) = \frac{v^*}{k} \cdot \ln\left(\frac{Z}{Z_0}\right) \quad Z \gg Z_0$$

constant (~0.4)

surface roughness length

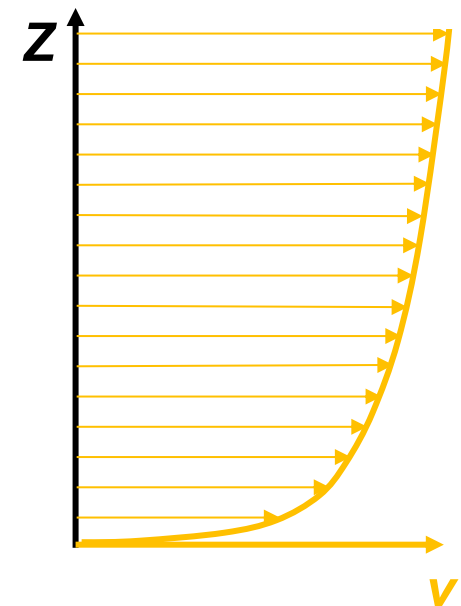

# Evaluating wind speed close to the ground

$$v(Z) = \frac{v^*}{k} \cdot \ln\left(\frac{Z}{Z_0}\right) \quad Z \gg Z_0$$

$v^*$  is the *friction velocity* (proportional to the square root of the turbulent shear stress), assumed constant in the lower boundary layer; since  $v^*$  is difficult to evaluate, the logarithmic law is usually rewritten in terms of a reference wind speed  $v(Z_r)$ , at reference height  $Z_r$ :

$$v(Z) = v(Z_r) \cdot \left( \frac{\ln(Z/Z_0)}{\ln(Z_r/Z_0)} \right) \quad Z \gg Z_0$$

This equation is valid up to heights of about 100 m, which is sufficient for application to most current wind turbines.

# Surface roughness length $Z_0$

Type of terrain	Typical value of $Z_0$ [m]
Mud Flats, Ice	$10^{-5}$ to $3 \times 10^{-5}$
Calm Sea	$2 \times 10^{-4}$ to $3 \times 10^{-4}$
Sand	$2 \times 10^{-4}$ to $10^{-3}$
Mown Grass	0.001 to 0.01
Low Grass	0.01 to 0.04
Fallow Field	0.02 to 0.03
High Grass	0.04 to 0.1
Forest and Woodland	0.1 to 1
Built up area, Suburb	1 to 2
City	1 to 4

Approximation:

$$Z_0 \approx h/30$$

with  $h$  = average height  
of roughness elements

# Measuring roughness $Z_0$

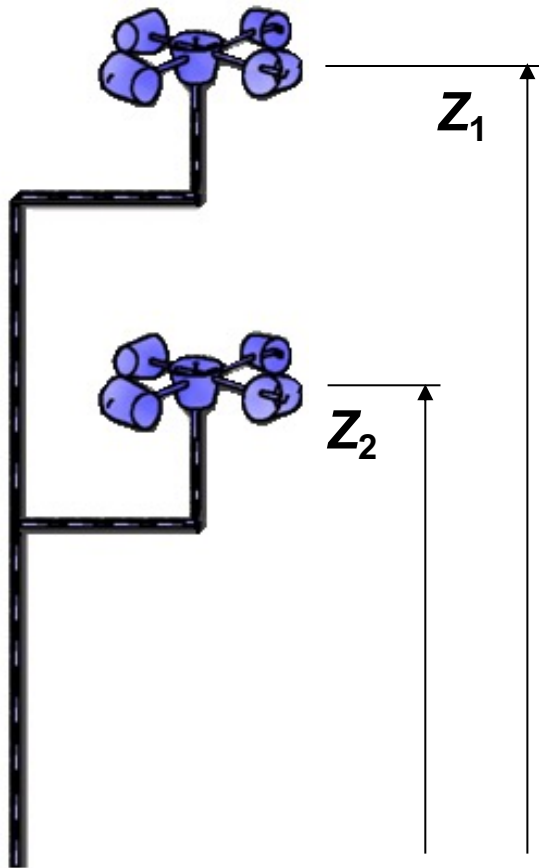

$$v(Z) = v(Z_r) \cdot \left( \frac{\ln(Z/Z_0)}{\ln(Z_r/Z_0)} \right) \quad Z \gg Z_0$$

The roughness length  $Z_0$  can be calculated directly if measurements are made simultaneously at two different heights,  $Z_1$  and  $Z_2$

Given that (with  $Z=Z_1$  and  $Z_r=Z_2$ ):

$$v(Z_1) \cdot \ln(Z_2/Z_0) = v(Z_2) \cdot \ln(Z_1/Z_0)$$

we get (expanding the logarithms):

$$\ln(Z_0) = \frac{v(Z_1) \cdot \ln(Z_2) - v(Z_2) \cdot \ln(Z_1)}{v(Z_1) - v(Z_2)}$$

# Anemometers

The measurement of wind **speeds** is done using a *cup anemometer* : a vertical axis and 3-4 cups that capture the wind; the rpm is registered electronically.

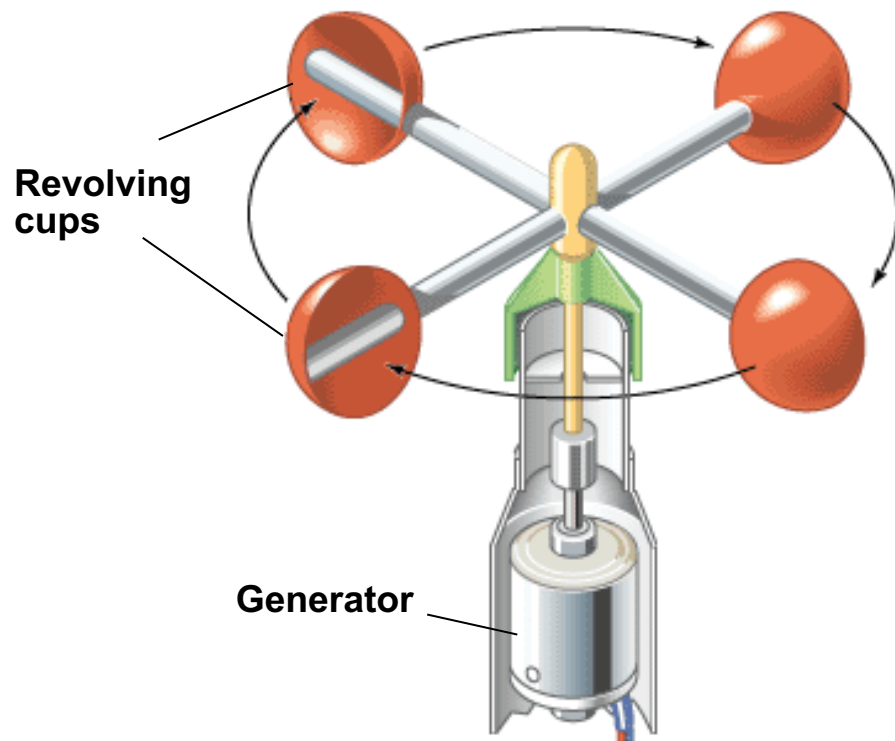

The anemometer is fitted with a wind vane to detect the wind **direction**; instead of cups, anemometers may be fitted with propellers.

Other types exist:  
*ultrasonic or laser anemometer,*  
*hot wire anemometer*

# Measuring wind

To be able to predict the performance of a wind turbine at a particular site, the developer must know the **characteristics** of this resource at the location in question

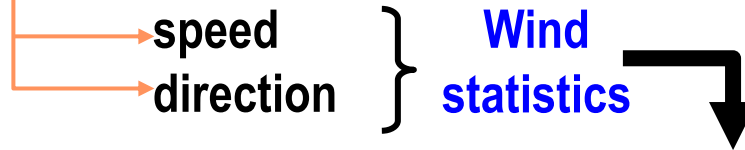

Speed variation time scales:

1. year
2. season
3. synoptic (= a passing weather system)
4. day
5. seconds (turbulence) →

Influences on:

- **Generation of energy forecasts** (scales 1 and 2)
- **Wind turbine design** (all scales)

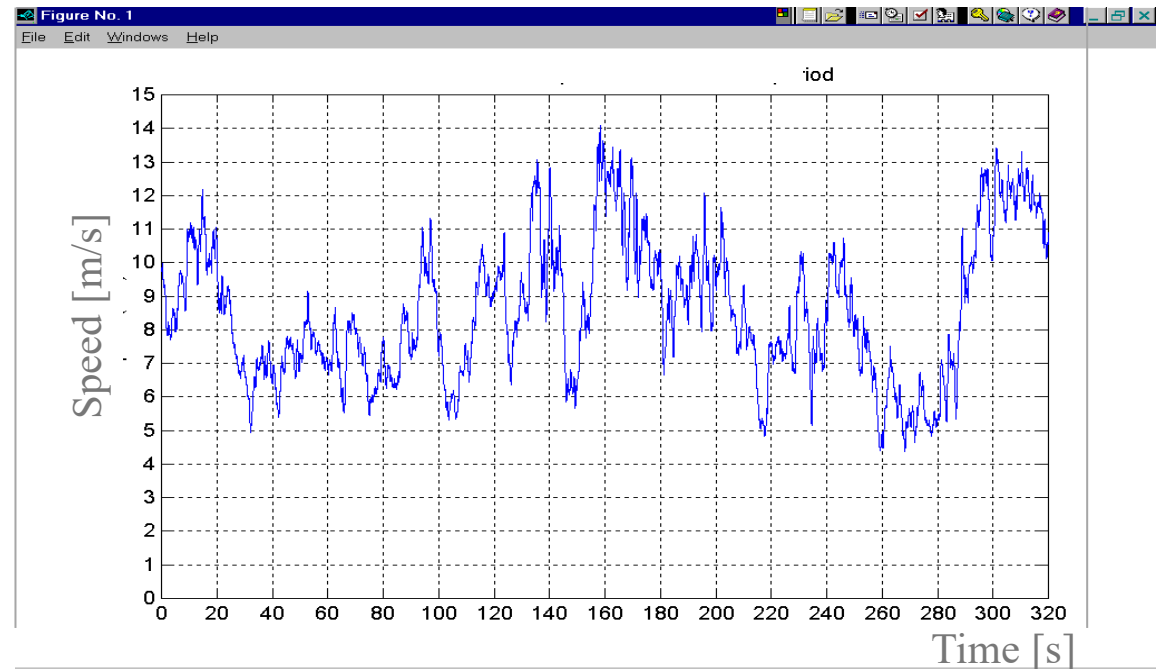

# 'Wind rose' diagram

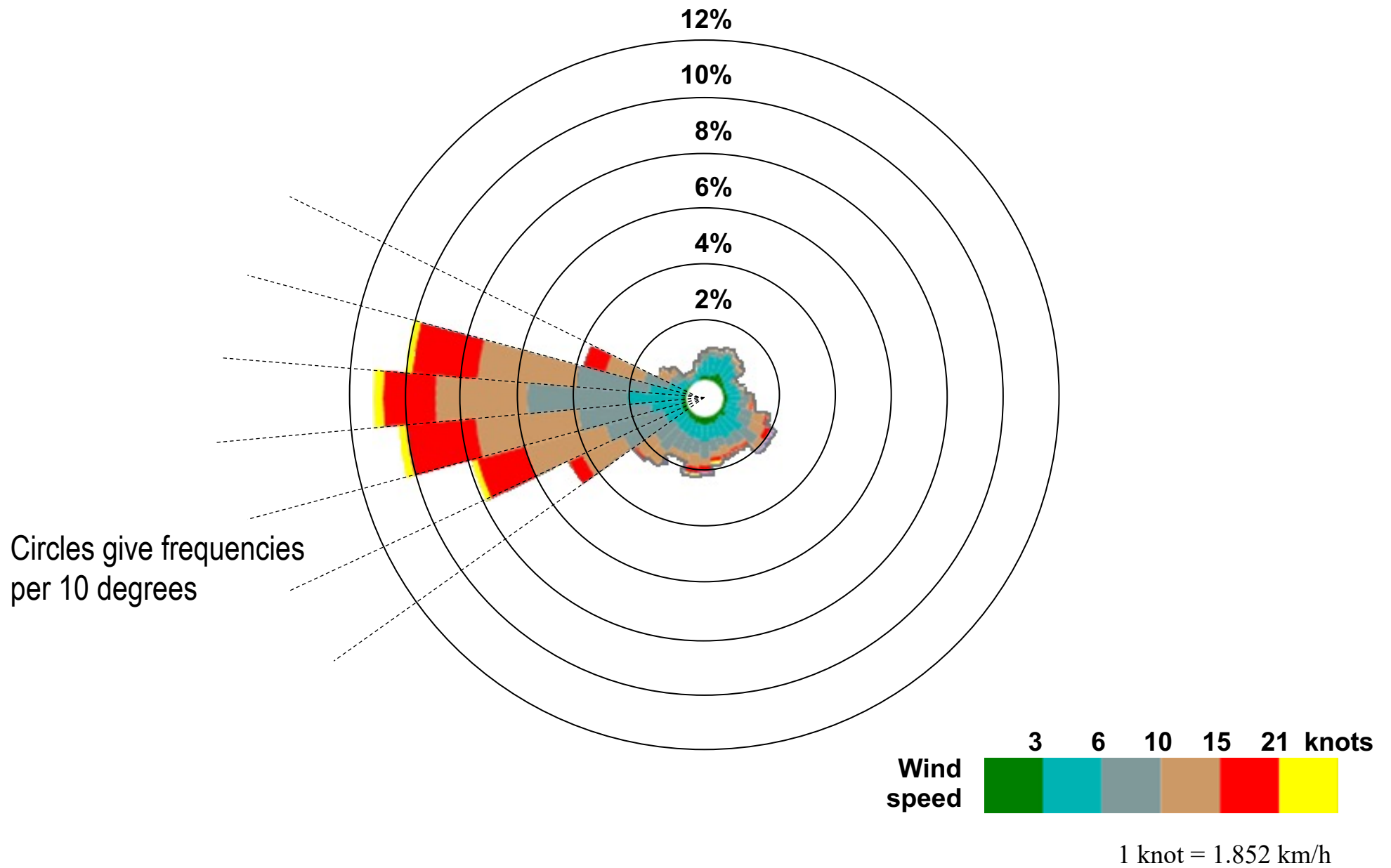

# Wind spectrum

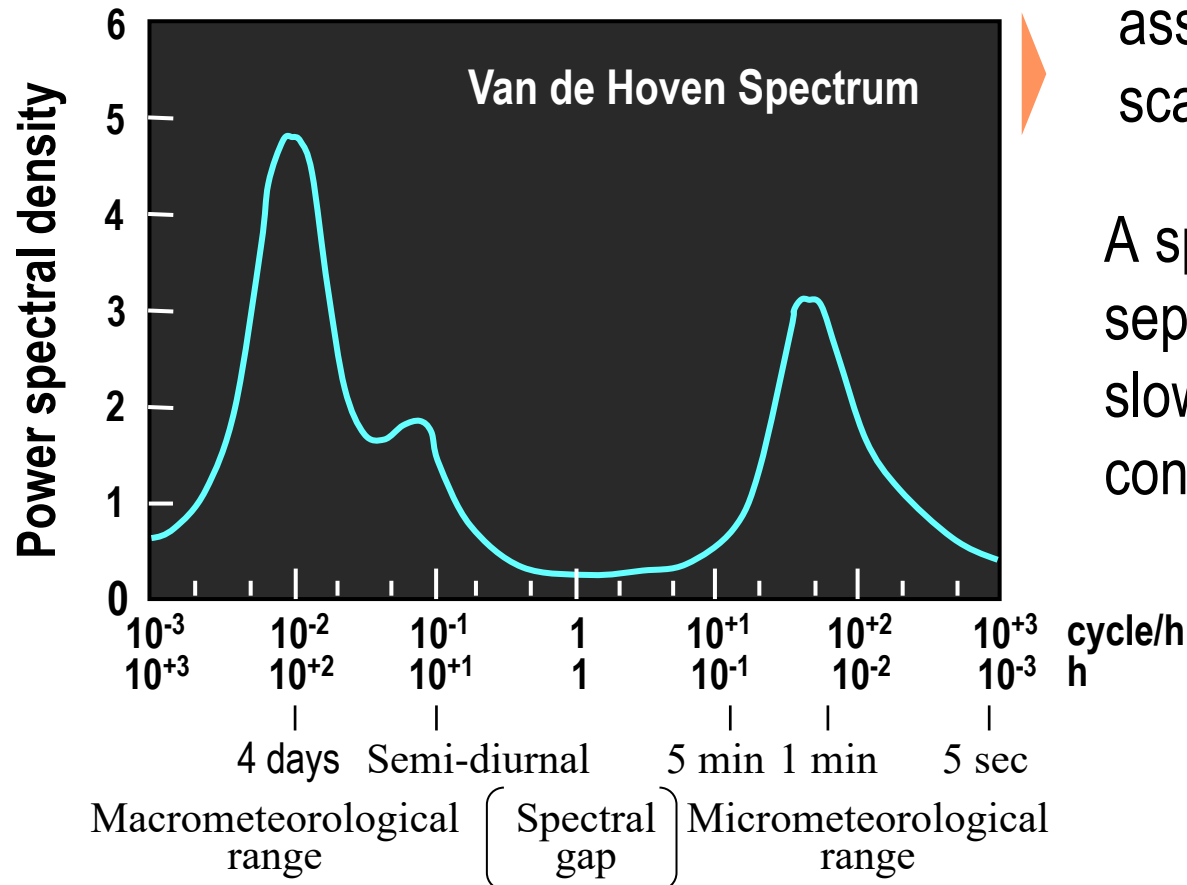

Variation in wind speed is associated with a particular time-scale or frequency.

A spectral gap, 10 minutes to 1 h, separates turbulent variation from slower variations ('steady conditions').

Time averaged wind speed values over an interval  $T$ :

$$\bar{v} = \frac{1}{T} \int_{t_0 - \frac{T}{2}}^{t_0 + \frac{T}{2}} v(t) dt$$

# → Wind speed distribution

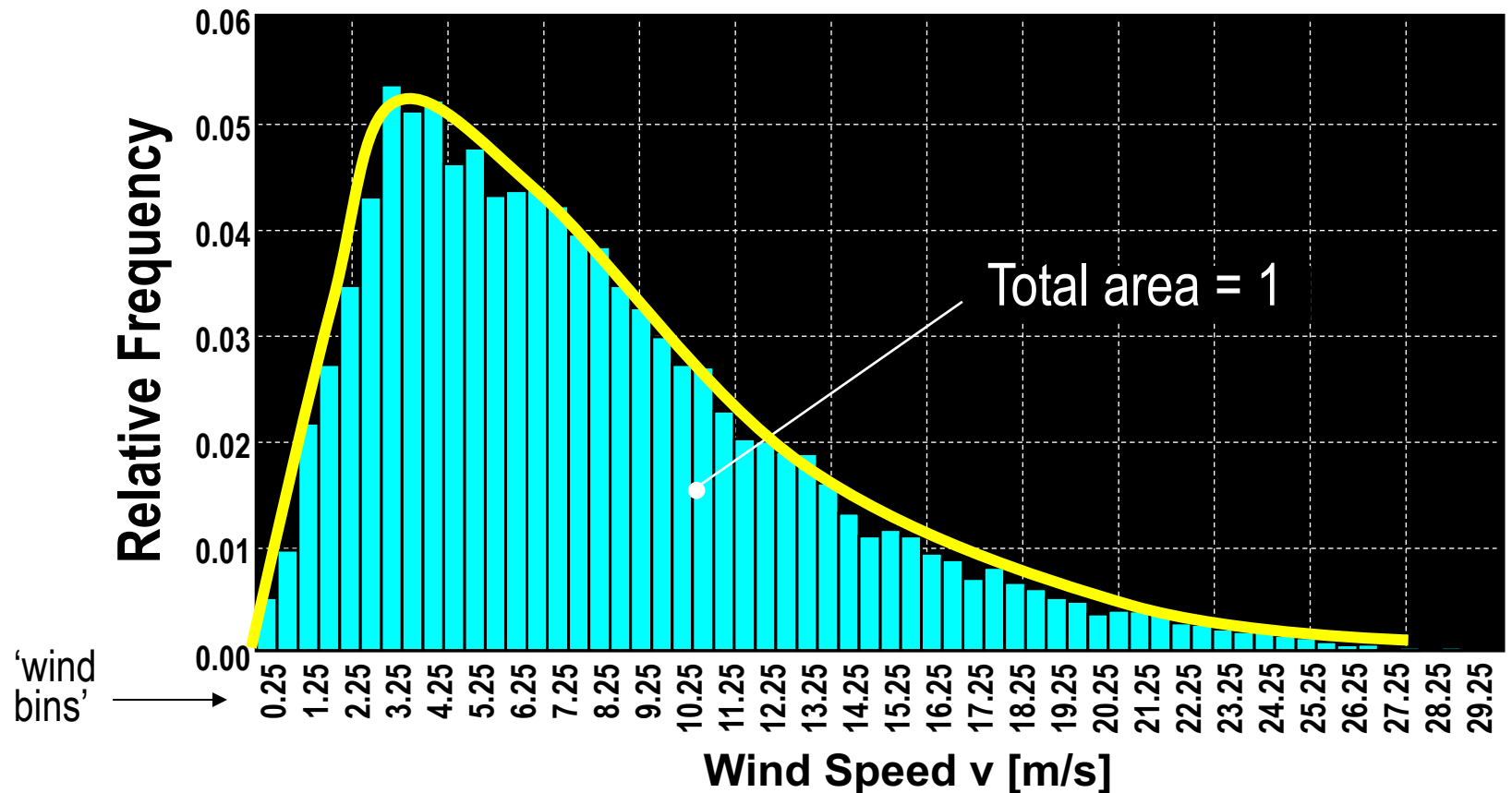

A suitable **probability** distribution for the wind speed  $v$  is required. The frequency distribution of wind speeds at most sites can be well represented by the two-parameter **Weibull** probability density function:

$$f(v) = \left(\frac{k}{c}\right) \cdot \left(\frac{v}{c}\right)^{k-1} \cdot \exp\left[-\left(\frac{v}{c}\right)^k\right]$$

**c: scale parameter**  
**k: shape parameter**

# Weibull distribution

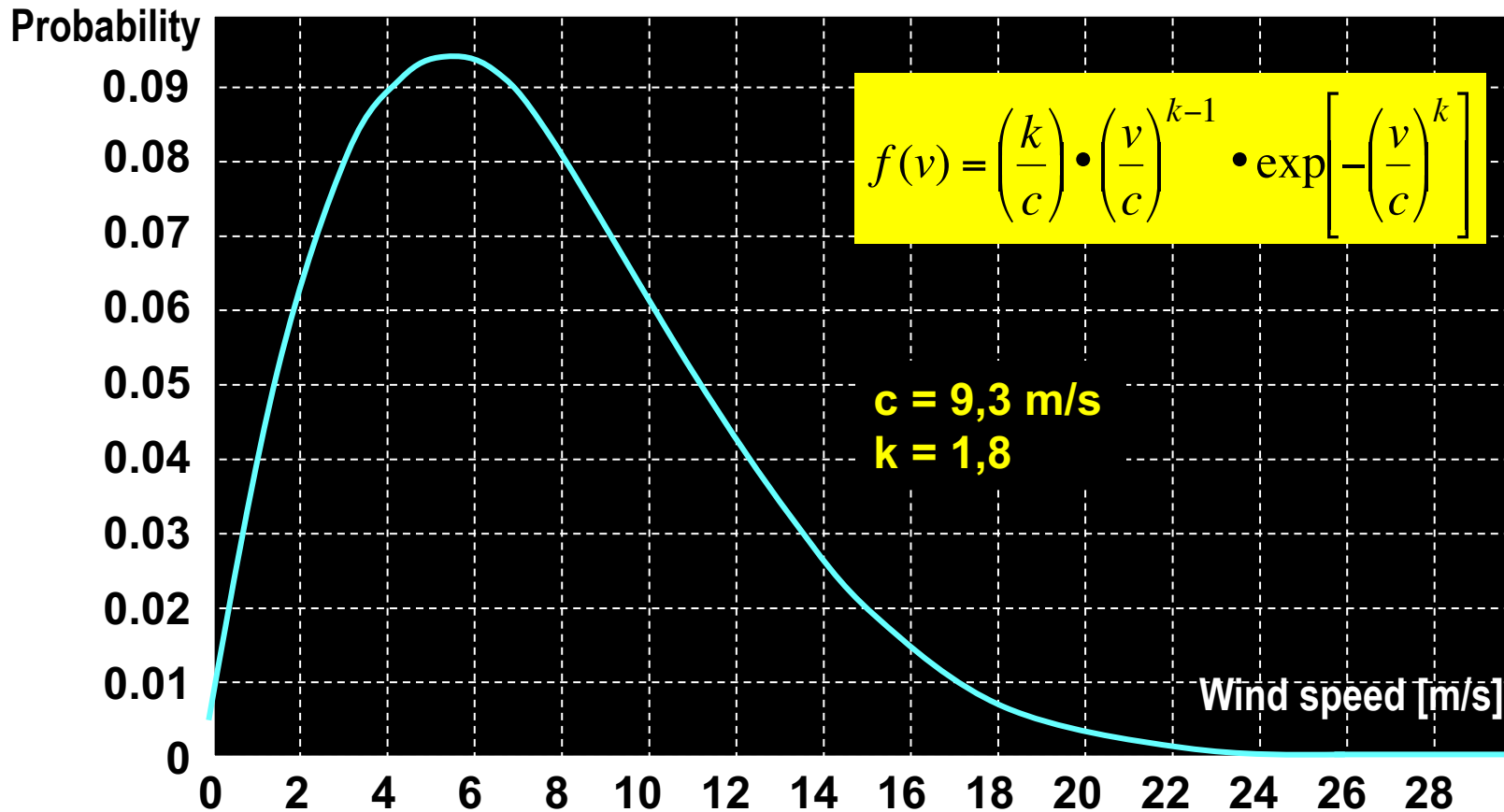

Average wind speed:

$$\bar{v} = c \cdot \Gamma\left(1 + \frac{1}{k}\right)$$

$$\Gamma(y) = \int_0^{\infty} \exp(-x) \cdot x^{(y-1)} dx$$

Gamma function

The **scale parameter  $c$**  is directly related to the **mean value of the wind speed  $v_{avg}$**  on the considered site (in the example graph: 63% of speeds are below 9.3 m/s, 37% are above).

The **shape parameter  $k$**  is related to the **variance** of the wind speed:

$$\sigma^2 = c^2 \left[ \left(1 + \frac{2}{k}\right) - \left(\Gamma\left(1 + \frac{1}{k}\right)\right)^2 \right]$$

# Effect of the shape parameter k

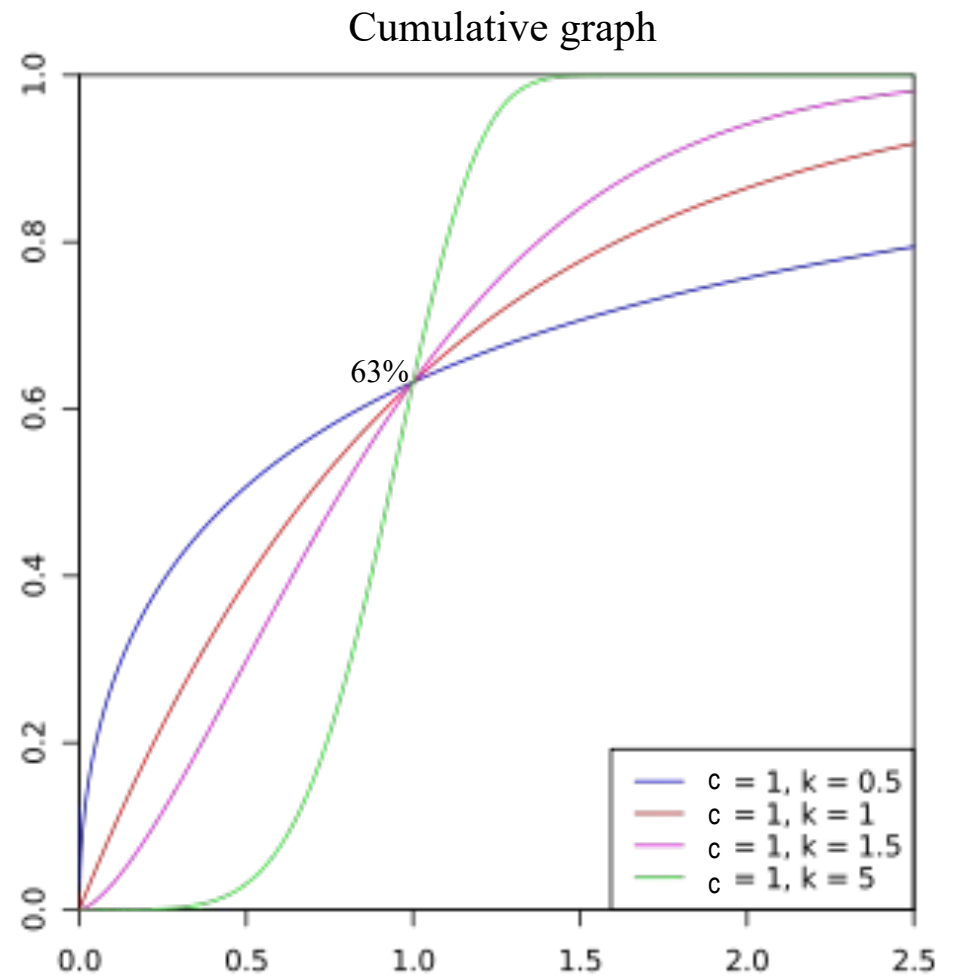
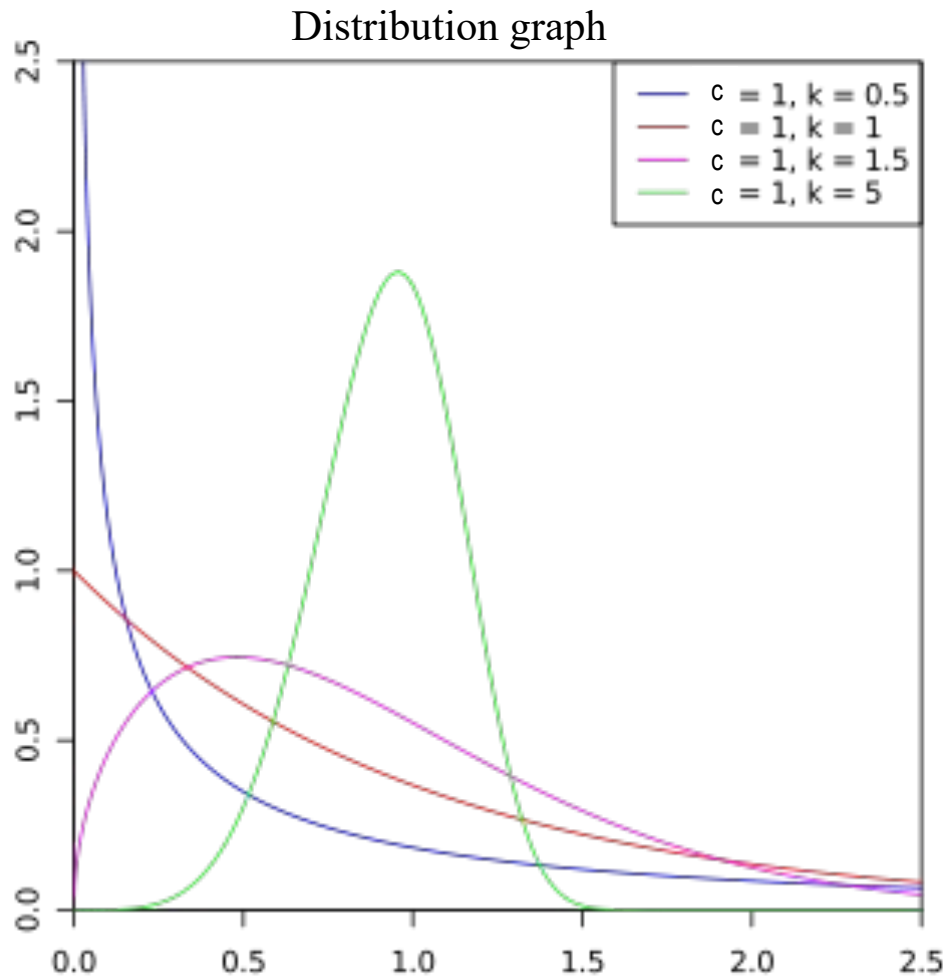

Typical values for k at wind sites = 2

# Estimation of Weibull parameters k and c

$$f(v) = \left(\frac{k}{c}\right) \cdot \left(\frac{v}{c}\right)^{k-1} \cdot \exp\left[-\left(\frac{v}{c}\right)^k\right]$$

↓ log

↓ log

$$\ln[-\ln(P)] = k(\ln(v^*) - \ln(c))$$

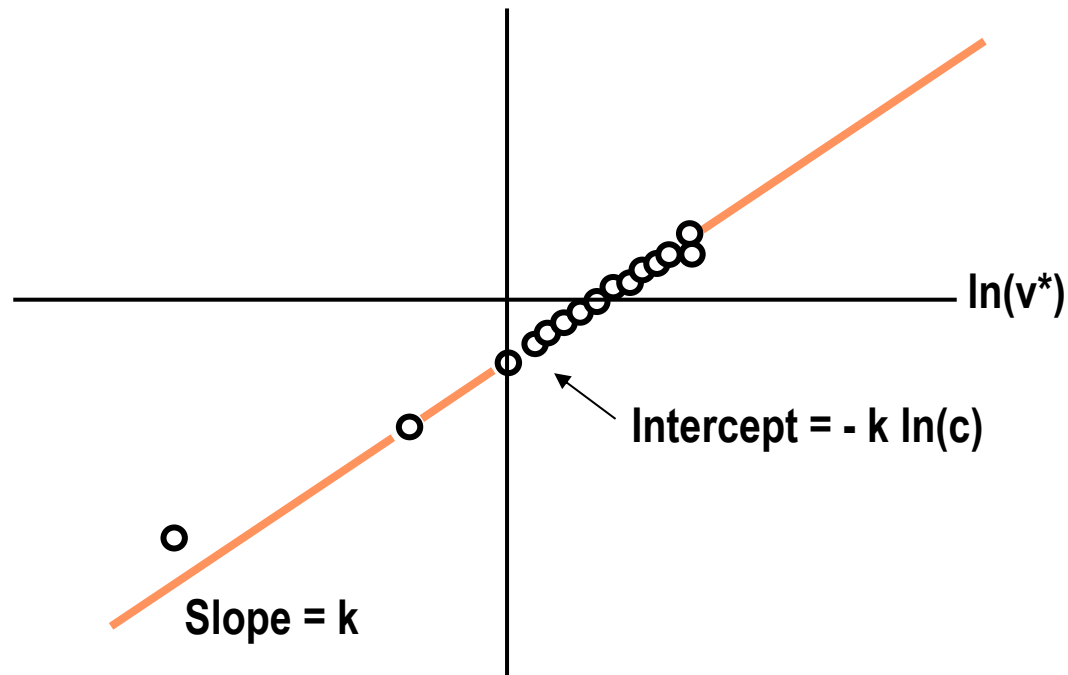

$$P = \text{probability for } (v > v^*) \\ = \exp[-(v^*/c)^k]$$

Alternatively, approximate formulas can be used:

for  $1.6 \leq k \leq 3.0$ :

$$c \approx \frac{2\bar{v}}{\sqrt{\pi}}$$

for  $1.8 \leq k \leq 2.3$ :

$$k \approx \frac{3}{2} \frac{c^3}{\langle v^3 \rangle} \sqrt{\pi}$$

# Wind power potential (Europe)

Exploitation is important in D, IT, ESP, DK,... Potential for further development exists in many European countries. Installed capacity increases >10%/yr.

Presently installed (2025): **300 GW**

Delivering **20%** of Europe's electricity (600 TWh<sub>el</sub> in 2025).

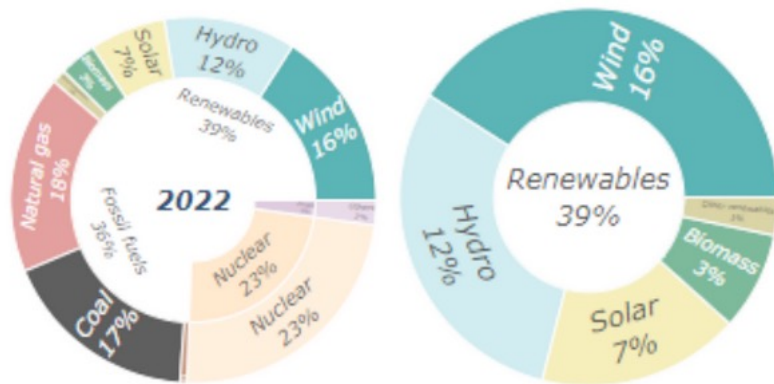





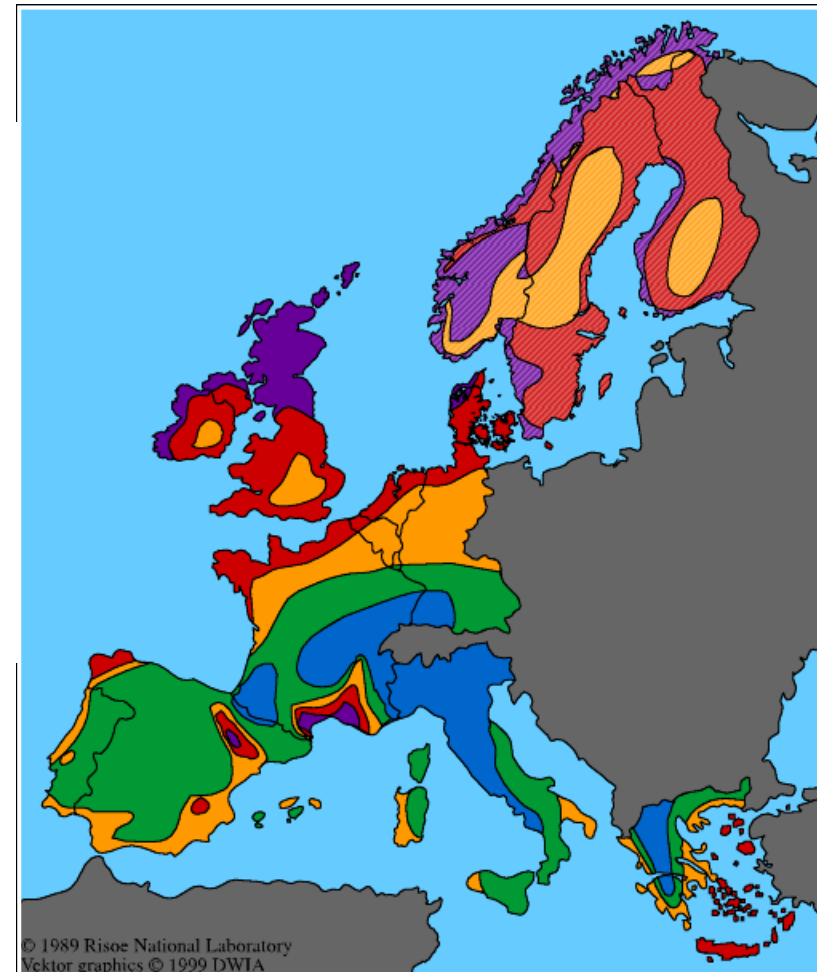

Figure6: Share of renewables in electricity supply in 2022; Source: ENER Chief Economist team, based on data from Fraunhofer, ENTSO-E

## Wind Resources at 50 metres above ground level for five different topographic conditions

	Sheltered terrain		Open plain		At sea coast		Open sea		Hills and ridges	
	[m·s <sup>-1</sup> ]	[W·m <sup>-2</sup> ]	[m·s <sup>-1</sup> ]	[W·m <sup>-2</sup> ]	[m·s <sup>-1</sup> ]	[W·m <sup>-2</sup> ]	[m·s <sup>-1</sup> ]	[W·m <sup>-2</sup> ]	[m·s <sup>-1</sup> ]	[W·m <sup>-2</sup> ]
	> 6.0	> 250	> 7.5	> 500	> 8.5	> 700	> 9.0	> 800	> 11.5	> 1800
	5.0-6.0	150-250	6.5-7.5	300-500	7.0-8.5	400-700	8.0-9.0	600-800	10.0-11.5	1200-1800
	4.5-5.0	100-150	5.5-6.5	200-300	6.0-7.0	250-400	7.0-8.0	400-600	8.5-10.0	700-1200
	3.5-4.5	50-100	4.5-5.5	100-200	5.0-6.0	150-250	5.5-7.0	200-400	7.0-8.5	400-700
	< 3.5	< 50	< 4.5	< 100	< 5.0	< 150	< 5.5	< 200	< 7.0	< 400



© 1989 Risoe National Laboratory  
Vektor graphics © 1999 DWIA

# Evolution 2000-2018 (EU power generation)

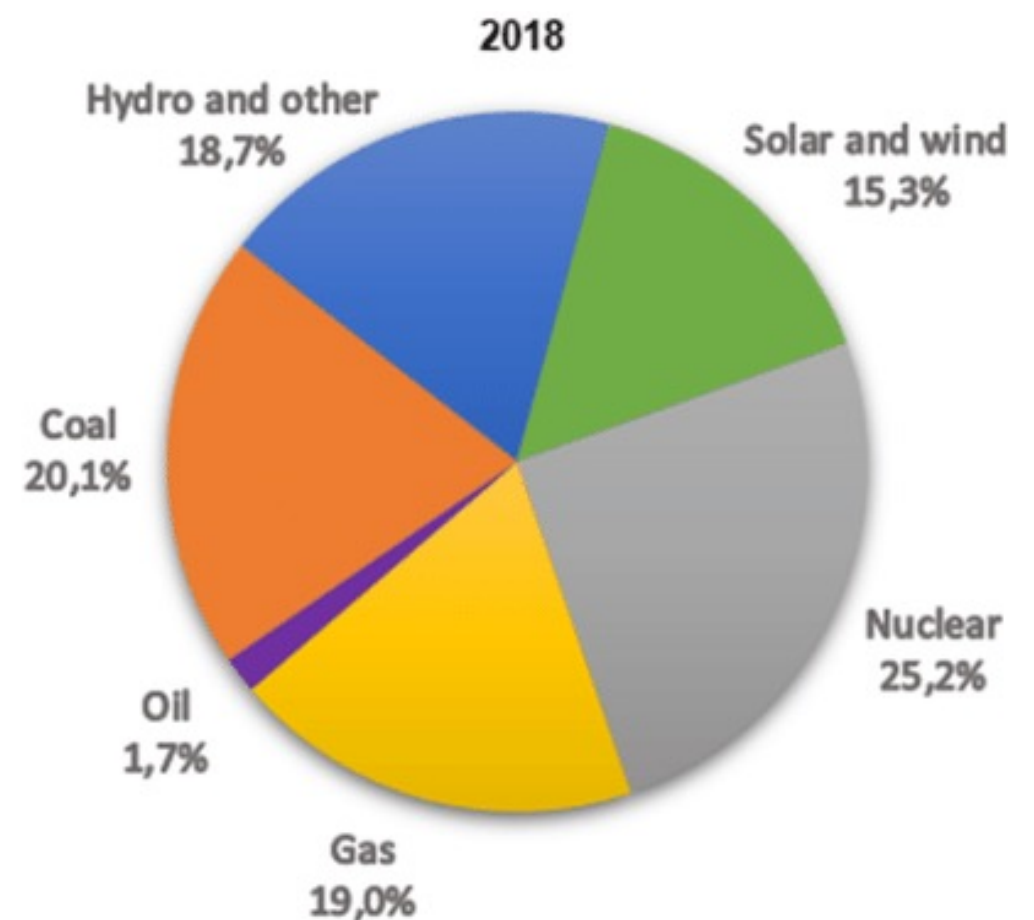
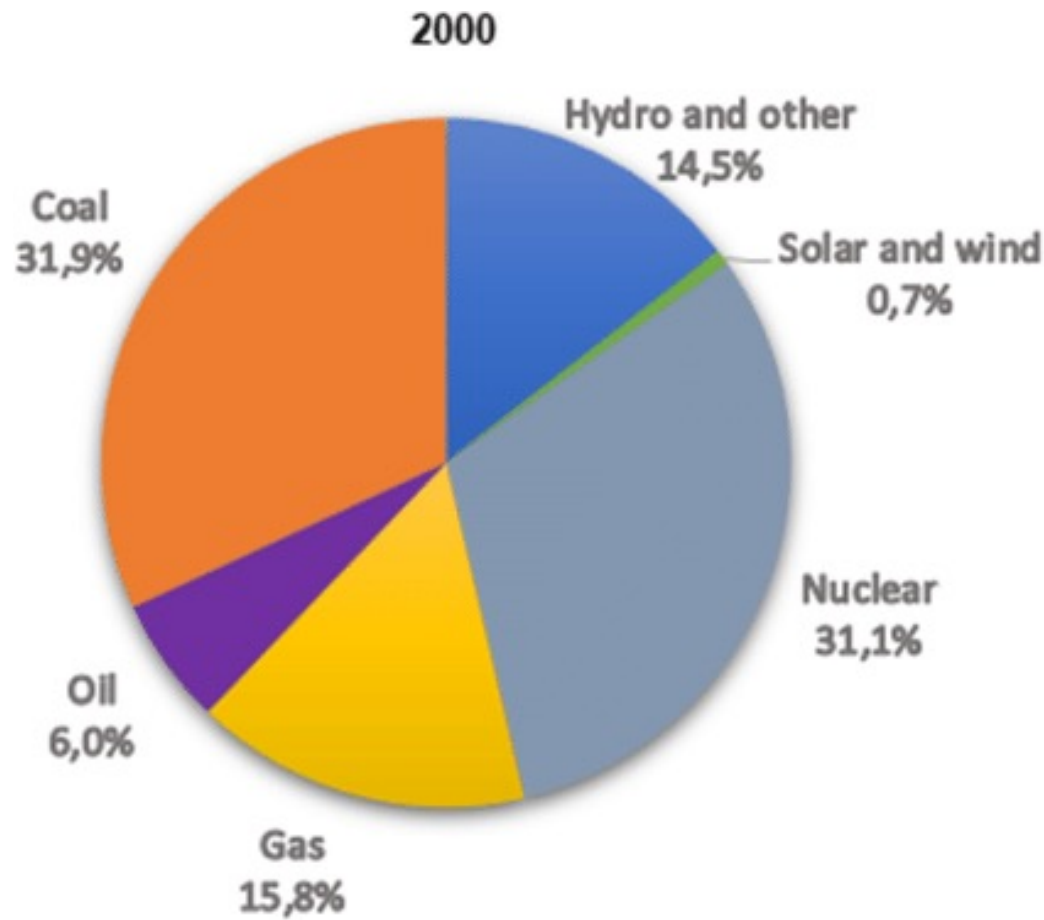

# Wind and solar PV rise in power

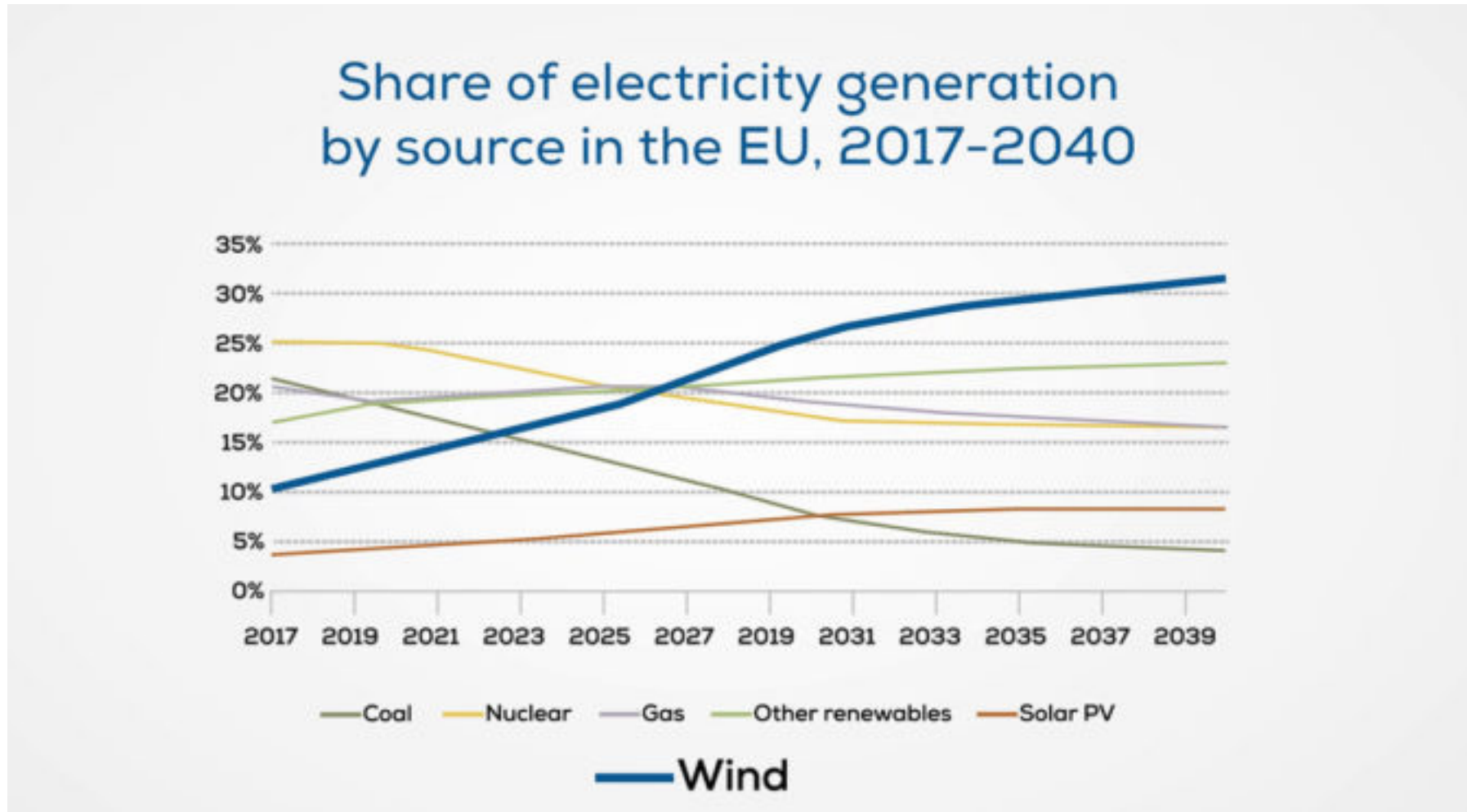

<https://www.evwind.es/2018/11/14/wind-energy-set-to-become-eus-largest-power-source-well-before-2030/65191>

# A continuous rise

Installed in 2025 : 1300 GW

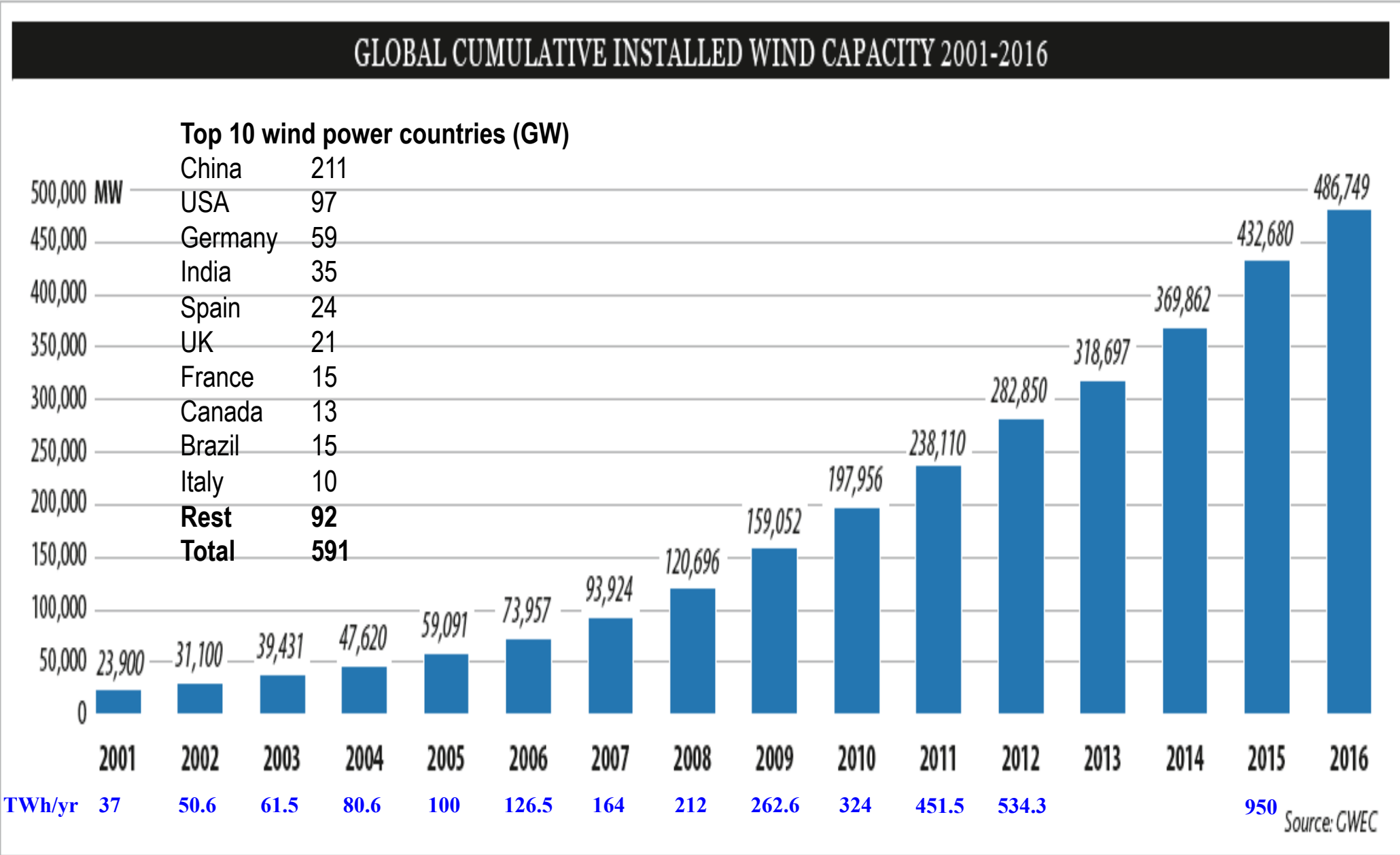

## Global Wind Power Forecast 2020-2030

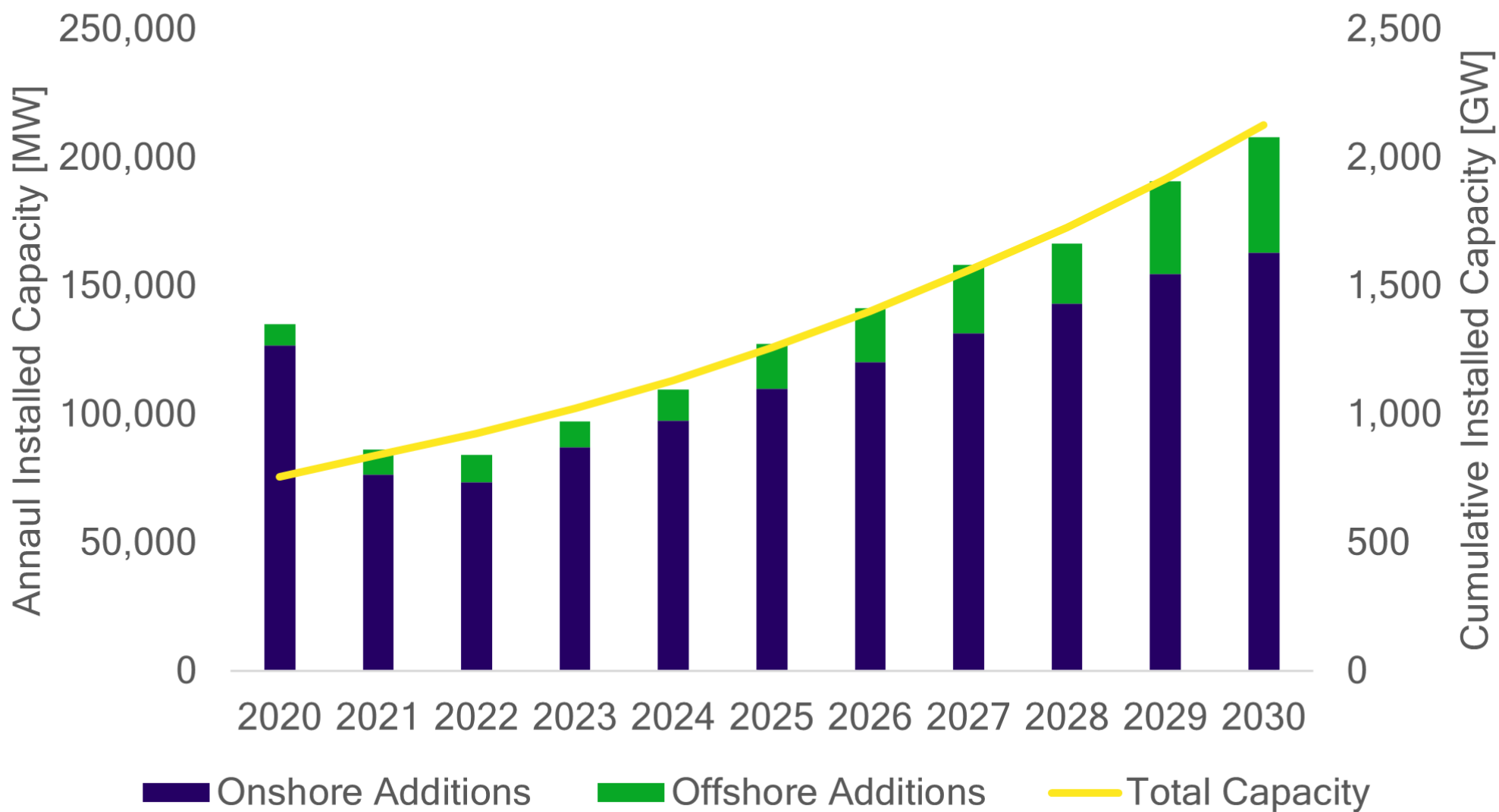

<https://www.enlit.world/library/wind-to-account-for-two-thirds-of-global-power-production-by-2030>

# At the Swiss scale:

Current : 0.16 TWhe (0.27%)

50 turbines

Low potential

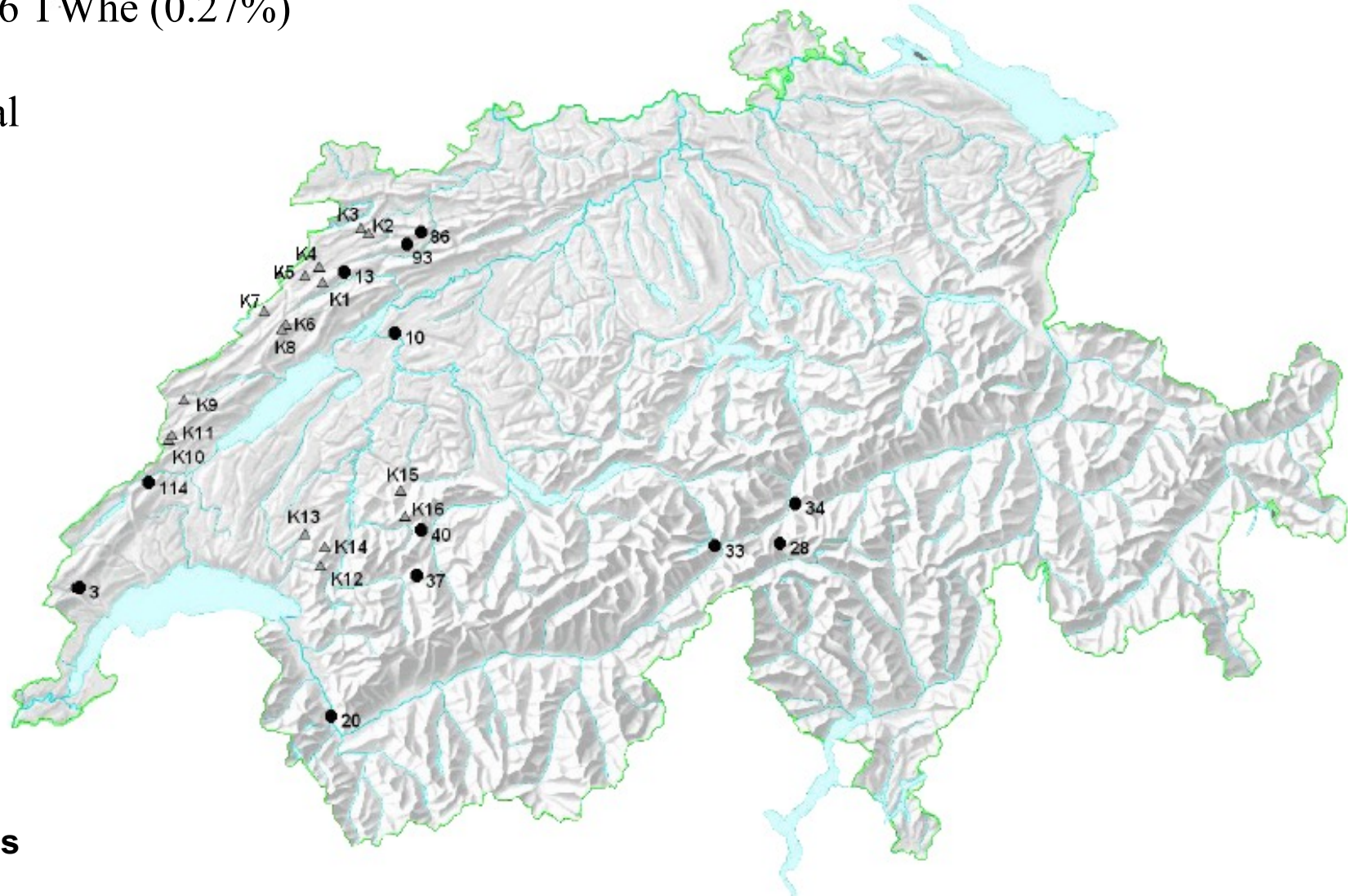

● Priority sites

△ Cantonal sites

# **Wind Energy - 2. Turbines & Technology**

# Learning objectives

- Derive the formula for wind power
- Explain the maximum power coefficient  $C_p$  (Betz, 59%)
- Discuss other turbine losses (wake, tip, drag)
- Explain wind turbine physics (lift/drag, torque-solidity,  $C_p$ - $\lambda$  curve)
- Explain turbine blade design (twist, chord, taper)
- Discuss the power operating range of a wind turbine and ways to regulate the power

# Kinetic power contained in the wind

Aim: compute the power  $\dot{W}_W$  in a wind of speed  $v_0$  flowing at right angles through an area  $A$

Air volume element swept in  $\Delta t$  :

$$V = A \cdot v_0 \cdot \Delta t$$

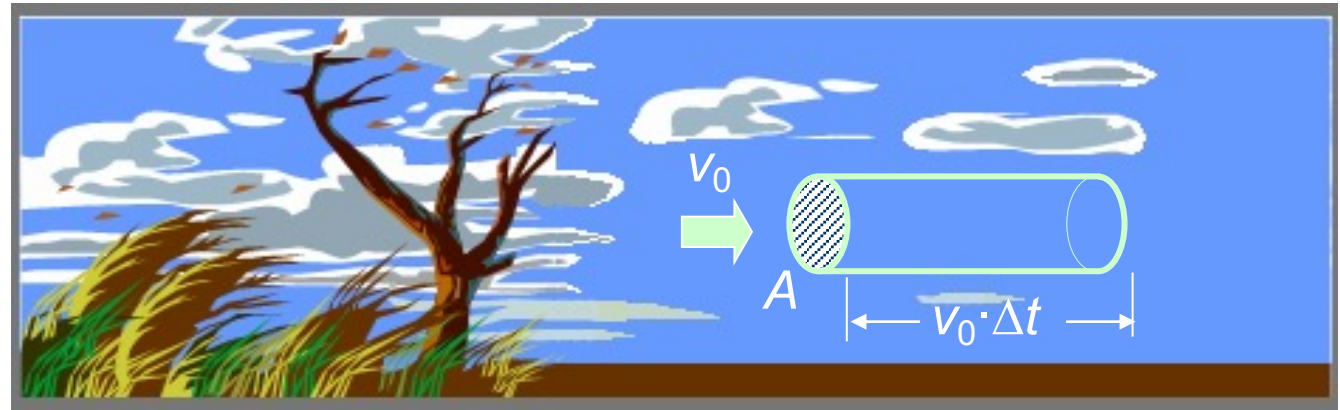

Kinetic energy of air:

$$W_{kin, air} = \frac{1}{2} m_{air} v_0^2 = \frac{1}{2} \rho_{air} V v_0^2 = \frac{1}{2} \rho_{air} A v_0 \Delta t v_0^2$$

In terms of Power:

$$\dot{W}_w = \frac{dW_w}{dt}$$

$$\dot{W}_{wind} = \frac{1}{2} \rho_{air} A v_0^3$$

EQUATION (1)

# ‘Actuator disc theory’ : placing a turbine in an air stream ‘tube’

The kinetic energy contained in the wind can (**only partly**) be extracted using *wind turbines* (quite different from *water turbines*!)

As a 1<sup>st</sup> approximation, only the **mass** of air which passes through the rotor disc is affected.

Air **mass conservation** in the stream-tube (continuity, in kg/s) :

$$\rho \cdot A_T \cdot v_T = \rho \cdot A_1 \cdot v_1 = \rho \cdot A_2 \cdot v_2$$

$$\rightarrow A_T \cdot v_T = A_1 \cdot v_1 = A_2 \cdot v_2$$

EQUATION (2)

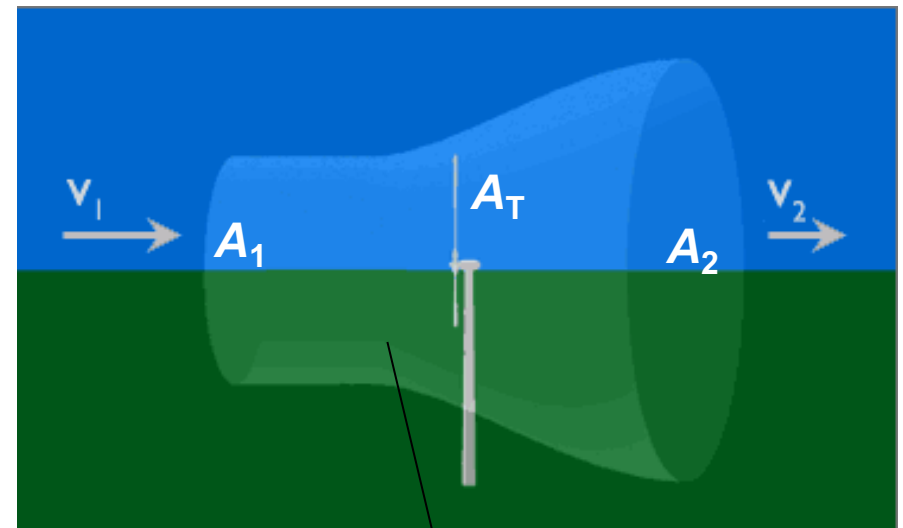

stream-tube

# Extracting energy from the wind: pressure and speed

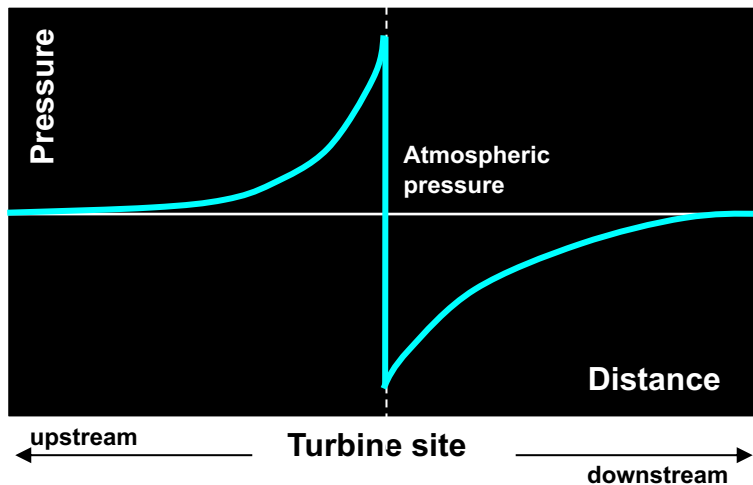

The turbine (or *aerogenerator*) first causes the **approaching air** to slow down gradually, which results in a **rise in the static pressure**.

**Across the turbine-swept surface** there is a **drop in static pressure** such that, on leaving, the air is below the atmospheric pressure level.

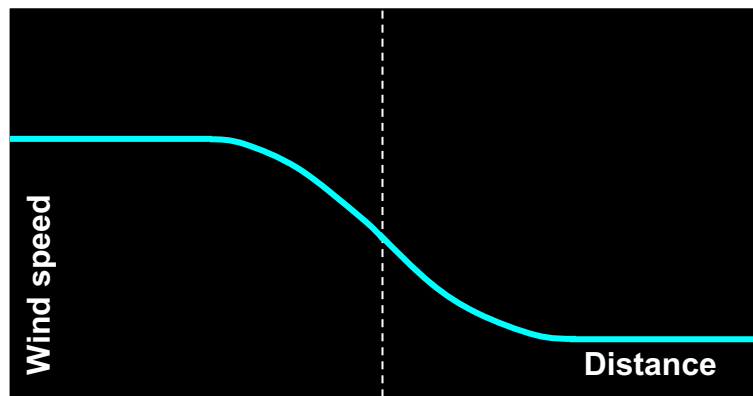

As the air proceeds **downstream**, the **pressure climbs back to the atmospheric** value causing a further slowing down of the wind.

↑ the kinetic energy is extracted only partially!

# Defining the control volume. Bernoulli equation

If the surface  $A_T$  is swept by the blades of a horizontal-axis wind turbine of diameter  $D$ , the disturbed air flux affects a volume (**control volume**) having a cross-section **significantly larger** than  $A_T$

1. Change of momentum  $d(mv)$  in  $dt$ :  $F = \text{force} = d(mv)/dt$ , and  $v_0 = \text{“free” wind speed}$  :

$$\cancel{F \cdot dt} = \underbrace{\rho \cdot A_T \cdot v_T \cdot dt}_{m \text{ (const)}} \cdot (v_1 - v_2) = \cancel{\rho \cdot A_T \cdot v_T \cdot dt} \cdot (v_0 - v_2)$$

deceleration force of the oncoming air stream (=change in momentum) against the turbine generates a pressure force on the turbine

$$v_{in} = v_{out} = v_T$$

2. Resultant of the pressure forces acting on the device  $\rightarrow F = A_T \cdot (P_{in} - P_{out})$

$$A_T \cdot (P_{in} - P_{out}) = \rho \cdot A_T \cdot v_T \cdot (v_0 - v_2)$$

EQUATION (3)

3. Bernoulli equation :

$$\frac{1}{2} \cdot \rho \cdot v_a^2 + P_a = \frac{1}{2} \cdot \rho \cdot v_b^2 + P_b$$

$$\left\{ \begin{array}{l} \text{upstream: } P_{in} - P_{atm} = \rho \frac{v_0^2 - v_T^2}{2} \\ \text{downstream: } P_{atm} - P_{out} = \rho \frac{v_T^2 - v_2^2}{2} \end{array} \right.$$

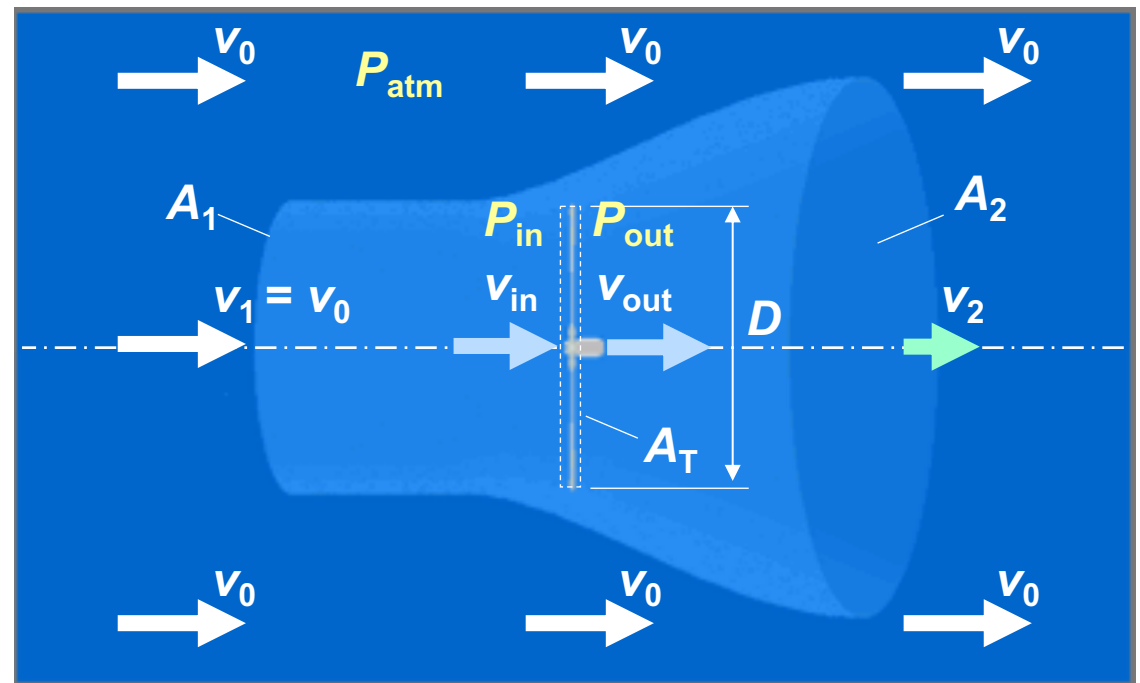

$$\rightarrow (P_{in} - P_{out}) = \frac{1}{2} \rho (v_0^2 - v_2^2) \quad \text{EQUATION (4)}$$

# Theoretical power extractable by the wind turbine

$$E_T = E_{kin,air}^{in} - E_{kin,air}^{out} = \frac{1}{2} m_{air} (v_0^2 - v_2^2)$$

$$\dot{W}_T = \frac{1}{2} \dot{m}_{air} (v_0^2 - v_2^2) = \frac{1}{2} \rho_{air} \underbrace{A_T v_T}_{A_2 \cdot v_2} (v_0^2 - v_2^2) \quad \text{(to eliminate } v_T)$$

*cf. EQUATION (2)  $A_T \cdot v_T = A_1 \cdot v_1 = A_2 \cdot v_2 \rightarrow v_T = A_2 v_2 / A_T$*

$$\dot{W}_T = \frac{1}{2} \rho_{air} A_T \frac{A_2}{A_T} v_2 (v_0^2 - v_2^2) \quad \rightarrow \text{multiply with } (v_0 / v_0) \text{ and isolate } (v_0)^2 \text{ to obtain :}$$

$$\dot{W}_T = \frac{1}{2} \rho_{air} A_T v_0^3 \frac{A_2}{A_T} \frac{v_2}{v_0} \left[ 1 - \left( \frac{v_2}{v_0} \right)^2 \right]$$

$$\dot{W}_T = \dot{W}_W \cdot C_P$$

Wind kinetic energy  
EQUATION (1)

Power Coefficient  $C_p (<1)$

How now to determine the value of the **power coefficient  $C_p$** , i.e. the ratio  $v_2 / v_0$  ?

The exit air speed  $v_2$  cannot go to zero, since a constant mass flow must be maintained within the stream tube; therefore we must have:  **$v_2 = x \cdot v_0$ , with  $0 < x < 1$**

# Determination of maximum $C_p$ (Betz Formula)

We find an expression for the ratio  $v_2 / v_0$  ( $=x$ ) with the help of EQUATIONS (3) and (4) higher:

EQUATION (3):

$$A_T \cdot \underbrace{(P_{in} - P_{out})}_{\substack{\text{EQUATION (4):} \\ P_{in} - P_{out}}} = \underbrace{\rho \cdot A_T \cdot v_T}_{A_2 \cdot v_2} \cdot (v_0 - v_2) \quad \Rightarrow \quad A_T \frac{1}{2} (v_0^2 - v_2^2) = A_2 v_2 (v_0 - v_2)$$

EQUATION (4):

$$P_{in} - P_{out} = \frac{1}{2} \rho (v_0^2 - v_2^2)$$

$$\frac{A_2}{A_T} = \frac{(v_0 + v_2)}{2v_2} = \frac{1+x}{2x}$$

$$\Rightarrow \dot{W}_T = \frac{1}{2} \rho_{air} A_T v_0^3 \frac{A_2}{A_T} \frac{v_2}{v_0} \left[ 1 - \left( \frac{v_2}{v_0} \right)^2 \right] = \frac{1}{2} \rho_{air} A_T v_0^3 \frac{1+x}{2x} \cdot x \cdot (1-x^2)$$

$\dot{W}_T$  reaches a maximum for  $(d\dot{W}_T/dx = 0)$  when  $x = 1/3$  !

→ **Betz formula :**

$$\dot{W}_T = \frac{1}{2} \rho_{air} A_T v_0^3 \cdot \left[ \frac{16}{27} \right] = 0.592 \dot{W}_W$$

**In theory, maximally 59% of the wind kinetic energy can be extracted by the turbine**

# Effective power coefficient $C_p$

$$C_P = \frac{\dot{W}_T}{\dot{W}_W} = \frac{\dot{W}_T}{\frac{1}{2} \rho_{air} A_T v_0^3} = \frac{(1+x)(1-x^2)}{2}$$

Betz limit :

$$C_p = 16/27 \approx 0.593$$

$$v_2(\text{out}) = v_1(\text{in})/3$$

$$v_T = 2v_1/3$$

$$A_2 = 3 A_1$$

$$A_T = 3 A_1 / 2$$

Practical values

$$0.35 \leq C_p < 0.5$$

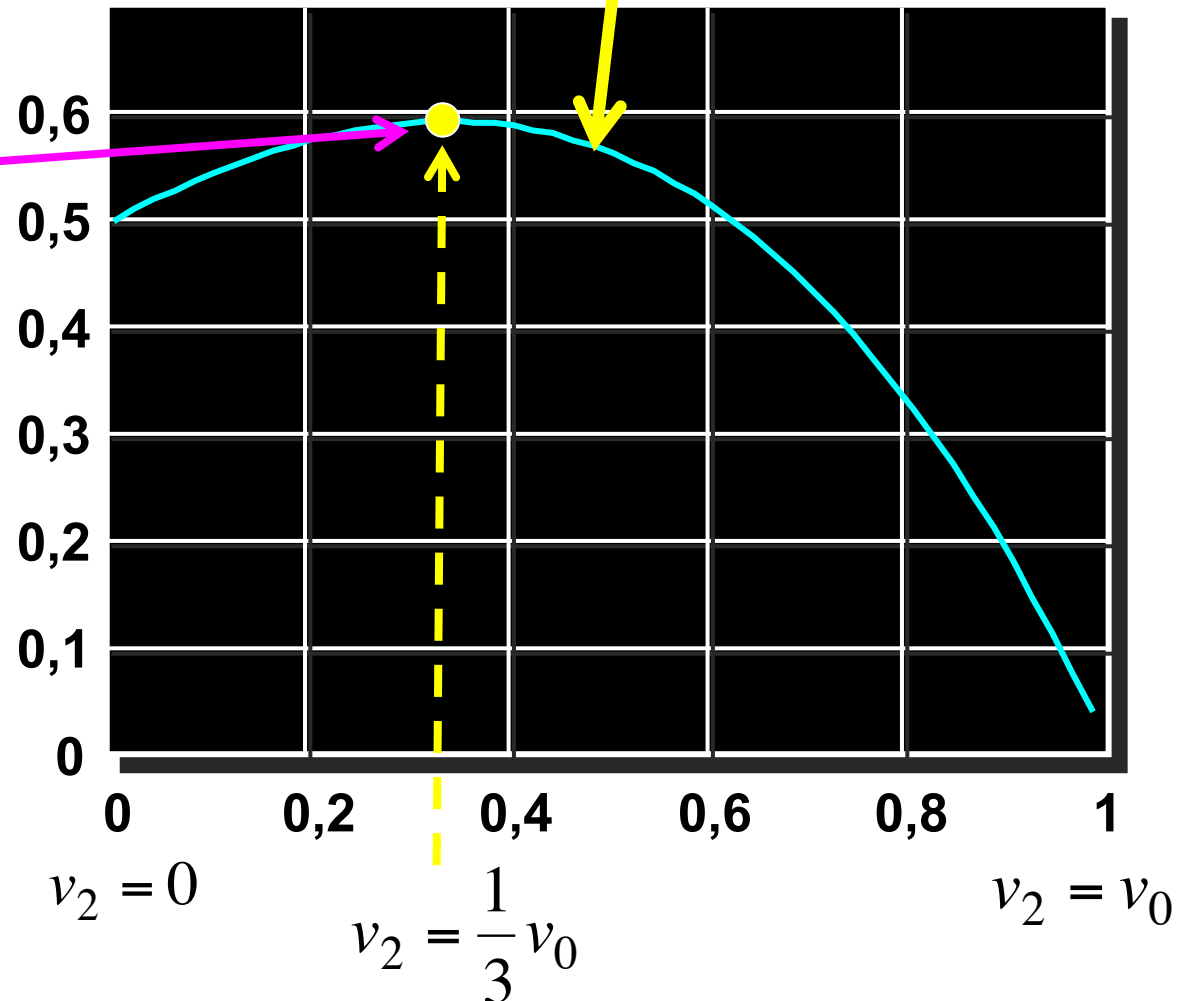

# Losses $C_p(\text{Betz}): 59\% \rightarrow C_p(\text{real}): \approx 40\%$

The 'actuator disc theory' does not account for the following losses, which represent  $\approx 1/3$  :

- ① **WAKE LOSS** (low  $v_0$ ) : the rotating turbine gives kinetic energy in form of a swirl (= a helical **vortex**) to incoming straight-moving air without tangential velocity.
- ② **TIP LOSS** (medium  $v_0$ ) : the blade tips themselves also create ('horseshoe') **vortices**. (can be seen as air 'overspill' between the high and low pressures below and above the blade; loss of lift)
- ③ **DRAG LOSS** (high  $v_0$ ): the blades rotating through air experience a **resistance** (drag force).

All these processes degrade the energy from the wind  $v_0$  which is not given to the turbine rotation.

# Wake loss



# Power goes as $v^3$

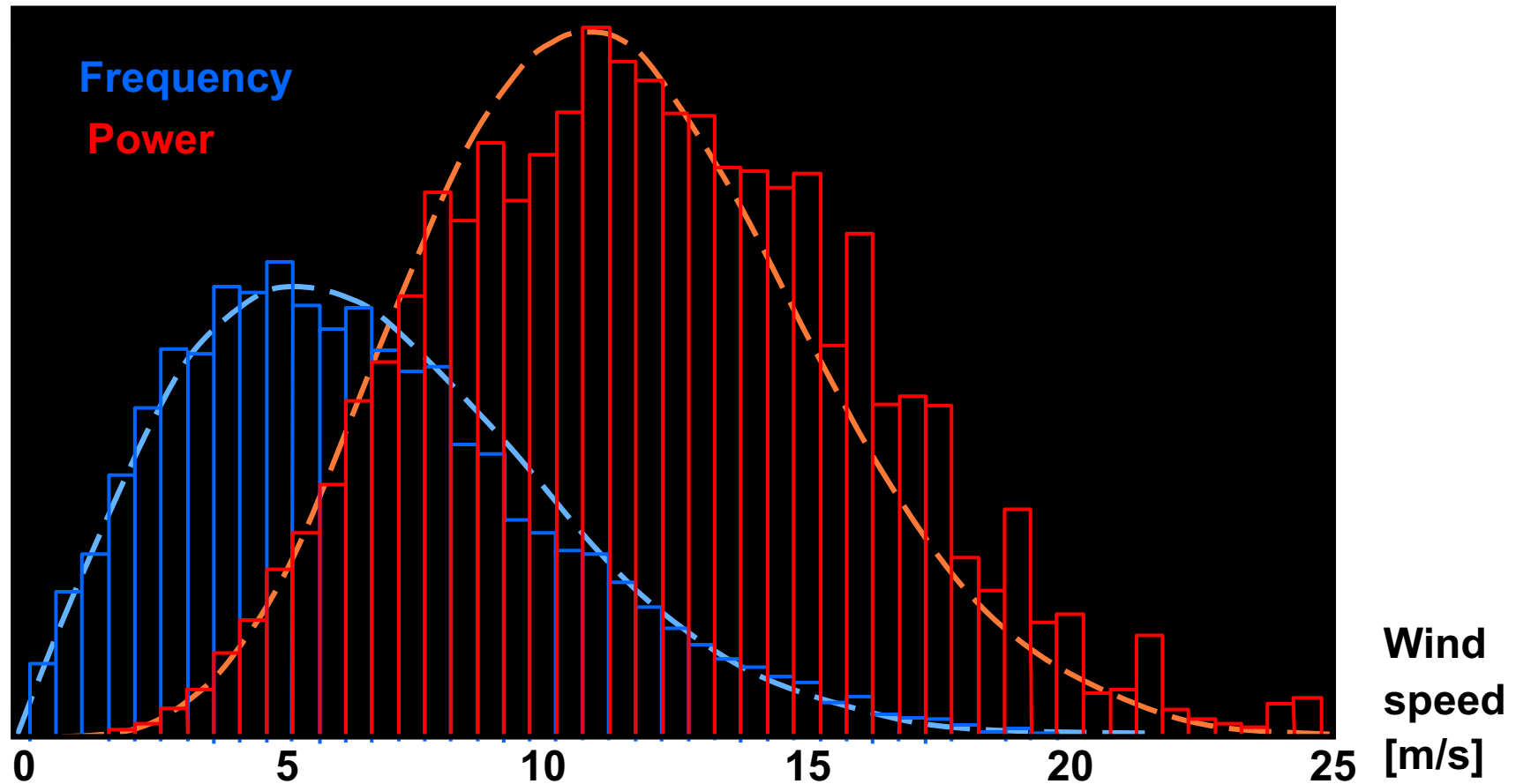

# Turbine size and power

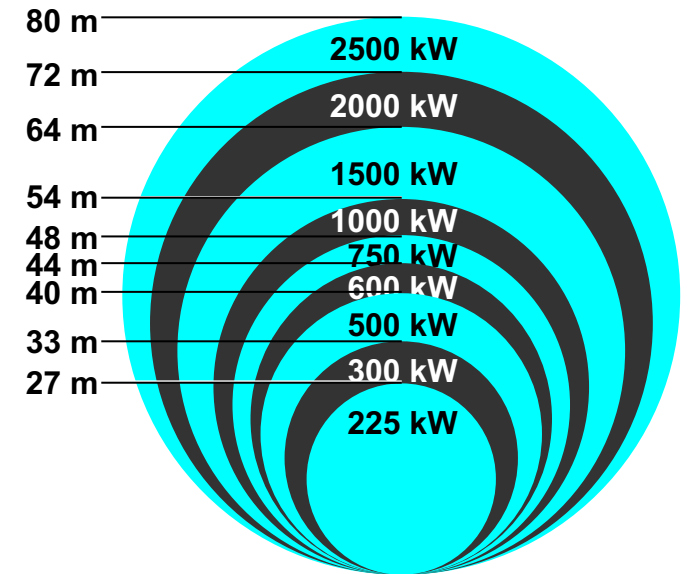
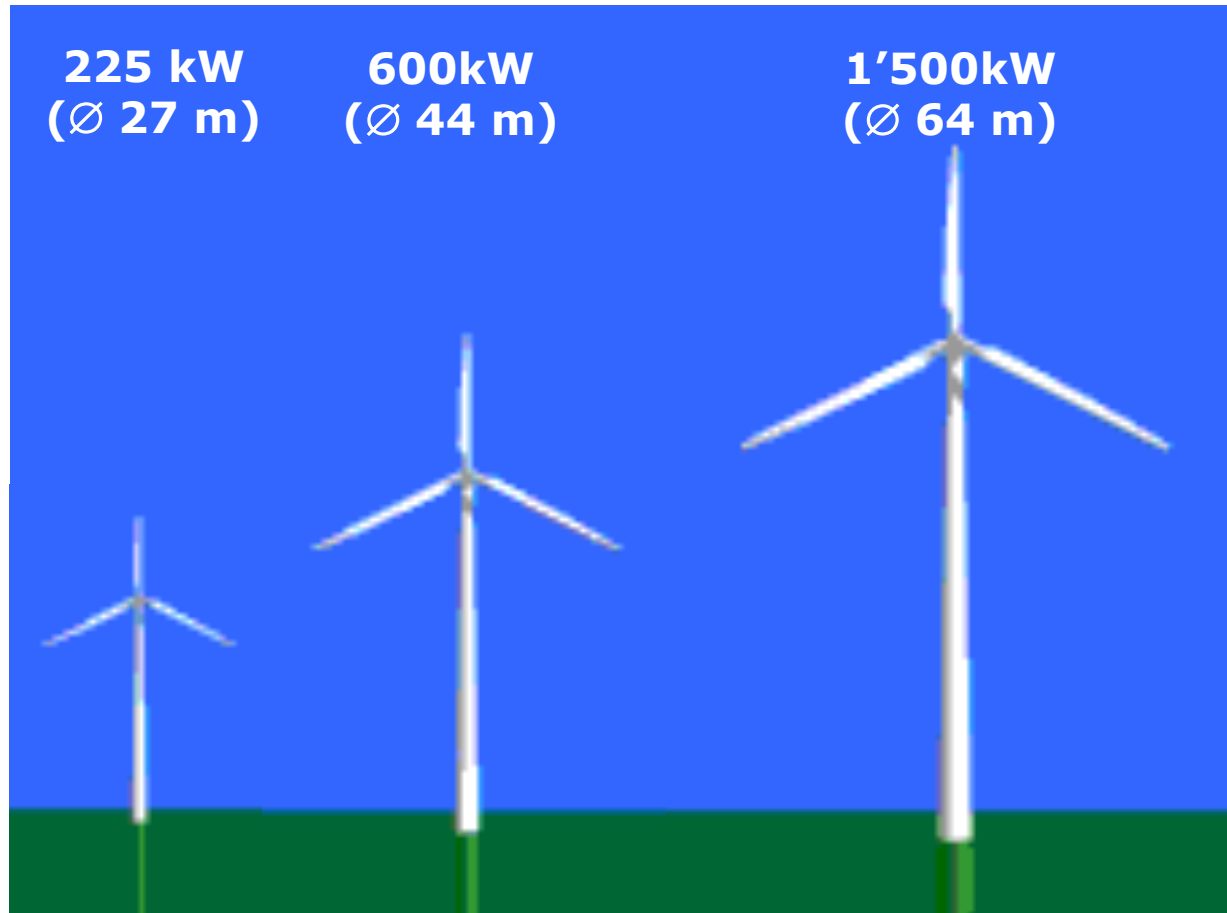

The diameter of a wind turbine increases with its rated power output

# Wind turbine velocity triangle (cf. hydro-turbines)

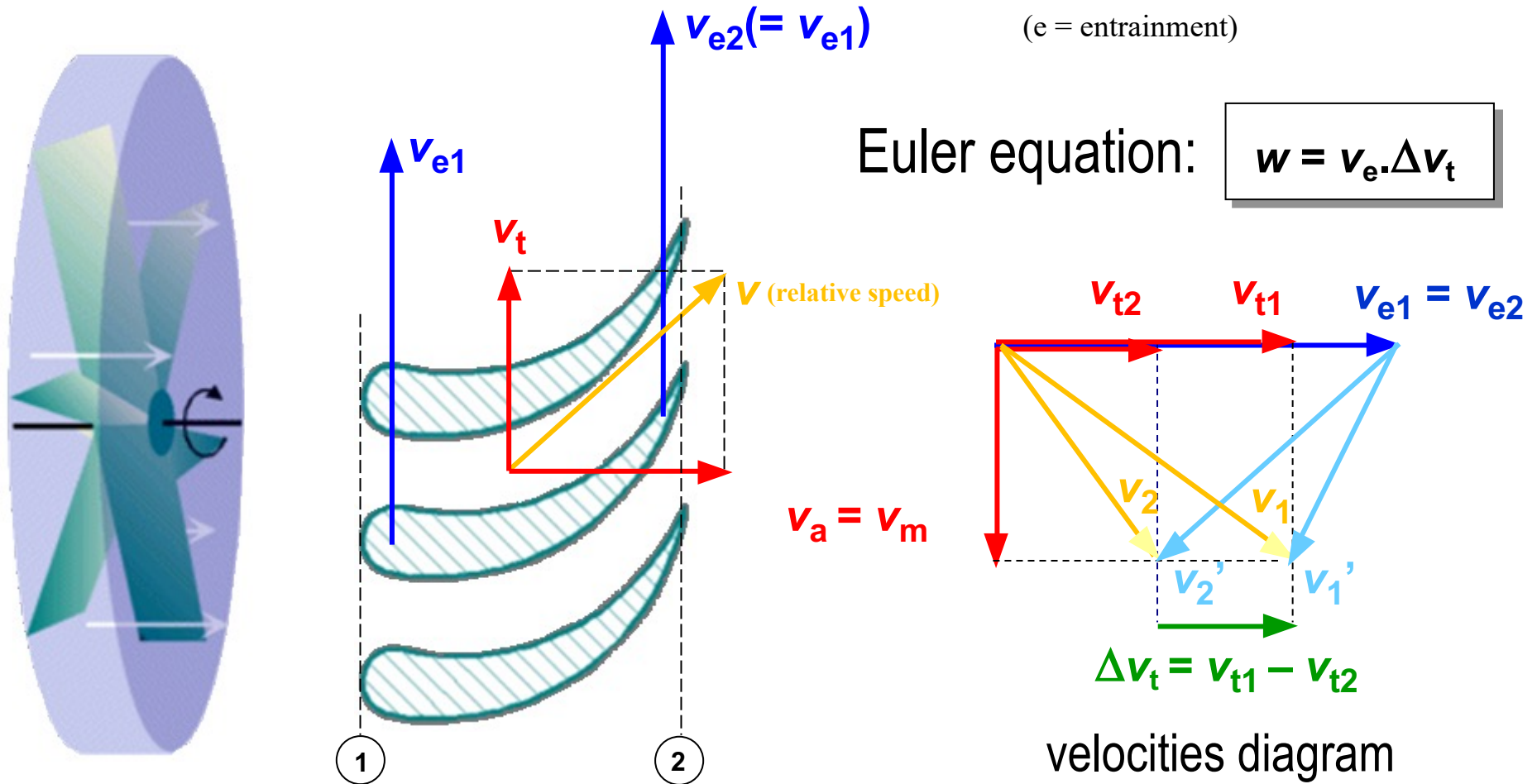

# Relative airfoil movement in the air

Blades shaped as airfoils are the most efficient to develop the necessary  $\Delta P$  across the disc formed by the rotating blades, to convert this into useful **torque**  $T$ .

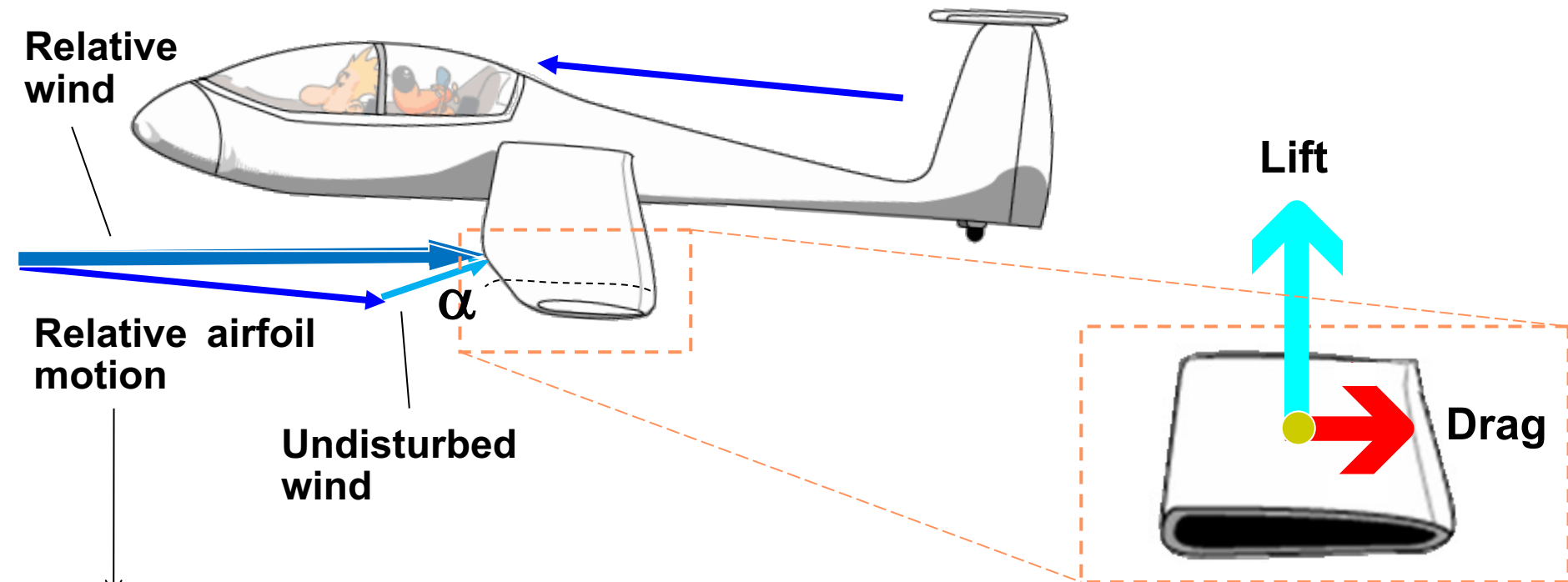

Air movement when regarding the wing (airfoil, blade) as *static*

An **angle of attack**  $\alpha$  is needed to produce LIFT.

The ratio LIFT  $L$  to DRAG  $D$ , at given  $\alpha$ , is to be maximized; this depends on the Reynolds number  $Re$  ( $Re$  is high for aircraft;  $Re$  is low for wind-turbines).

# Aerodynamic lift and drag

Air flowing over an aerofoil generates two forces :

*lift* and *drag*

Lift coeff. :  $K_L$   
 Drag coeff. :  $K_D$

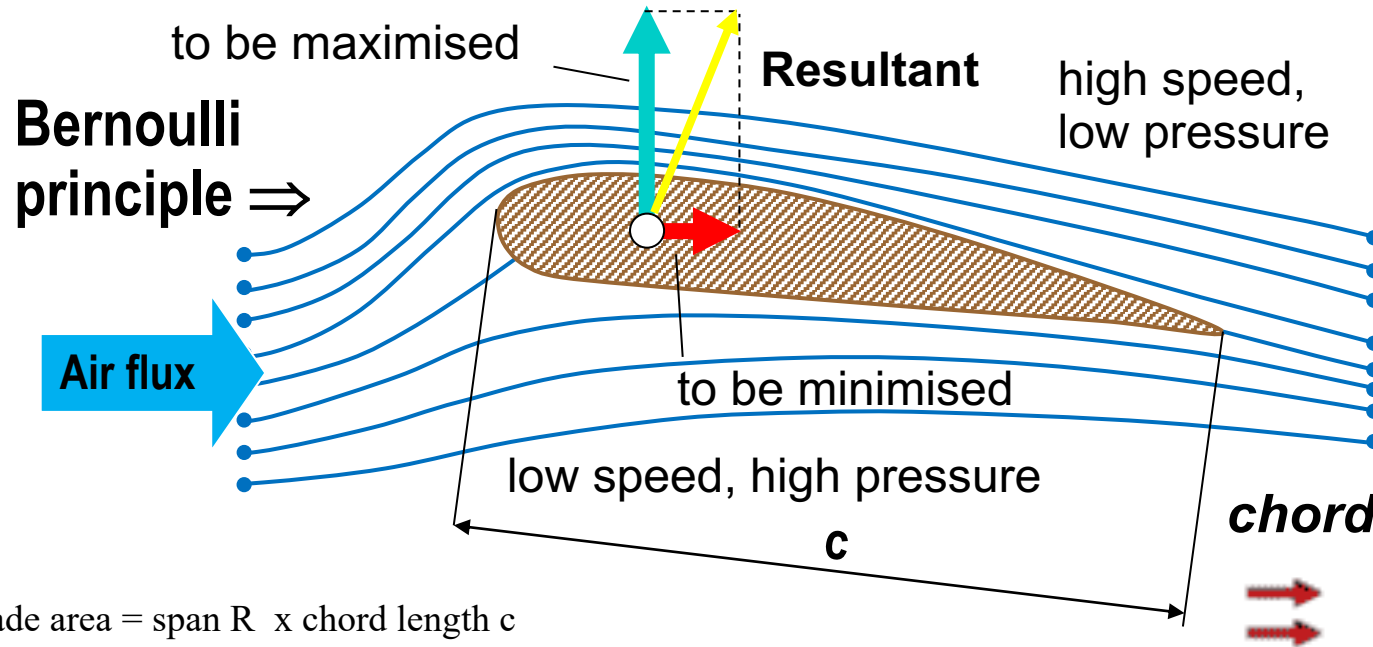

Blade area = span  $R$  x chord length  $c$   
 Pressure = Force / Area

**Force/unit span ( $R$ )**  
 prop  $\frac{1}{2} \cdot \rho \cdot v_0^2 \cdot c$

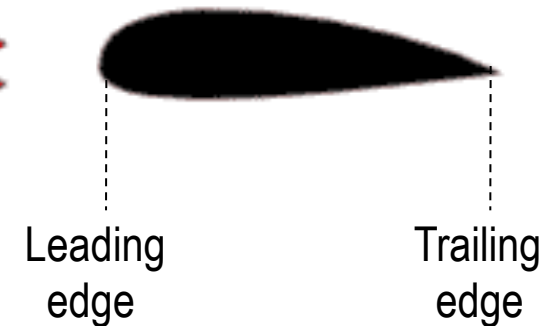

# Normalised LIFT and DRAG

= blade performance *independent* from blade size (c, R) and wind speed  $v_0$

$$F = \frac{\text{power}}{\text{speed}} = \frac{W_W}{v_0} = \frac{1}{2} \rho A v_0^2$$

Using this as DRAG force felt by the blade at attack angle  $\alpha = 90^\circ$ ,  
with blade area  $A = \text{blade length } R * \text{chord } c(r)$ ,  
we define the *normalised* LIFT and DRAG coefficients:

$$K_L = \frac{F_L}{\frac{1}{2} \rho A v_0^2} = \frac{F_L}{\frac{1}{2} \rho c R v_0^2} \qquad K_D = \frac{F_D}{\frac{1}{2} \rho A v_0^2} = \frac{F_D}{\frac{1}{2} \rho c R v_0^2}$$

The amount of Lift and Drag depends on the blade characteristics and  $\alpha$ .  
Maximum power is achieved for **maximal  $K_L/K_D$**  ratio ( $\approx 100$ ).

# Forces acting on the blades

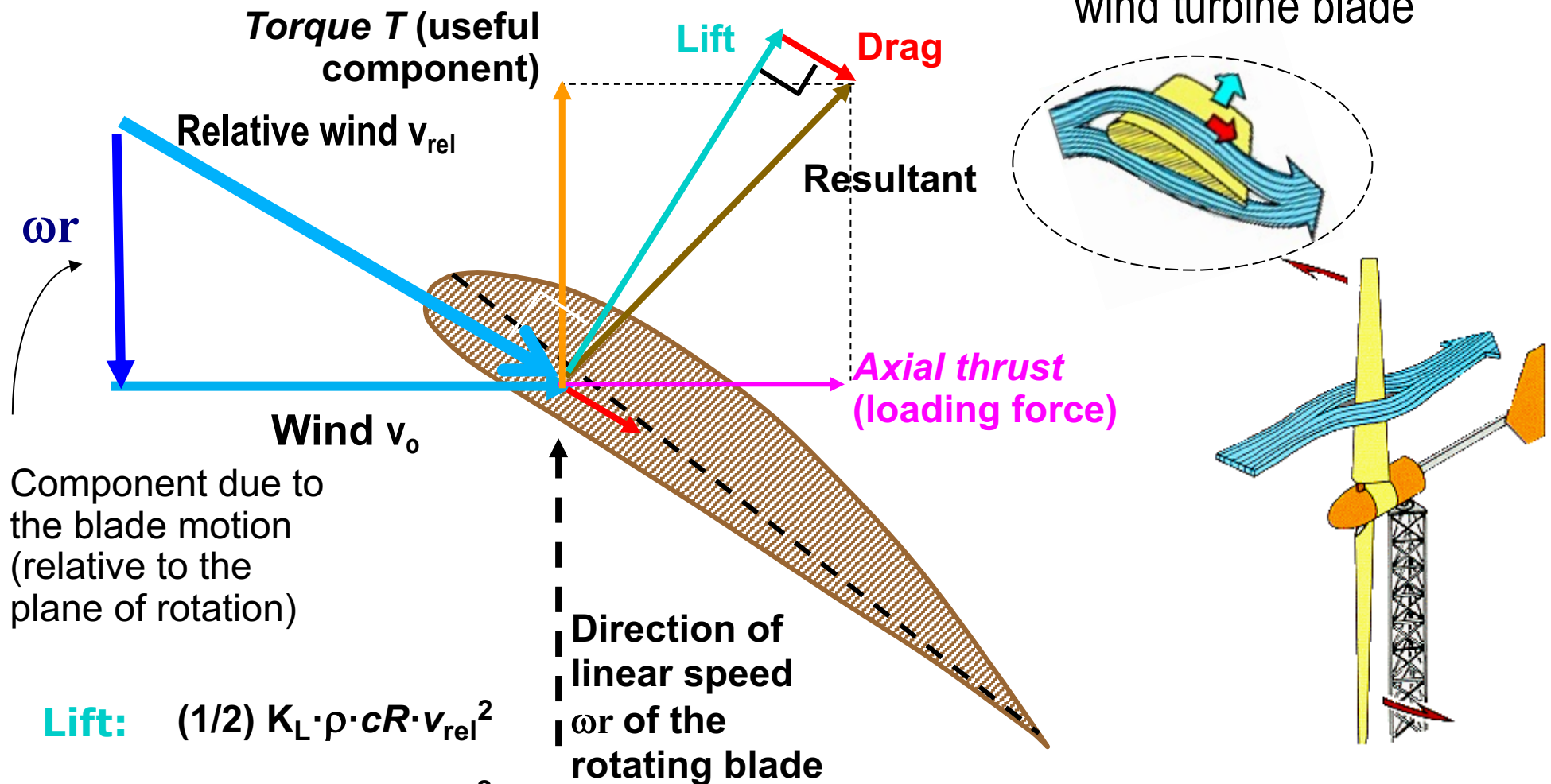

**Lift:**  $(1/2) K_L \cdot \rho \cdot cR \cdot v_{rel}^2$

**Drag:**  $(1/2) K_D \cdot \rho \cdot cR \cdot v_{rel}^2$

Note that as  $\omega$  changes (turbine rotation speed), for constant wind speed  $v_0$ , so will  $v_{rel}$  and  $\alpha$ , changing the LIFT and the resulting net force on the blades.

# Attack angle $\alpha$ , pitch angle $\beta$

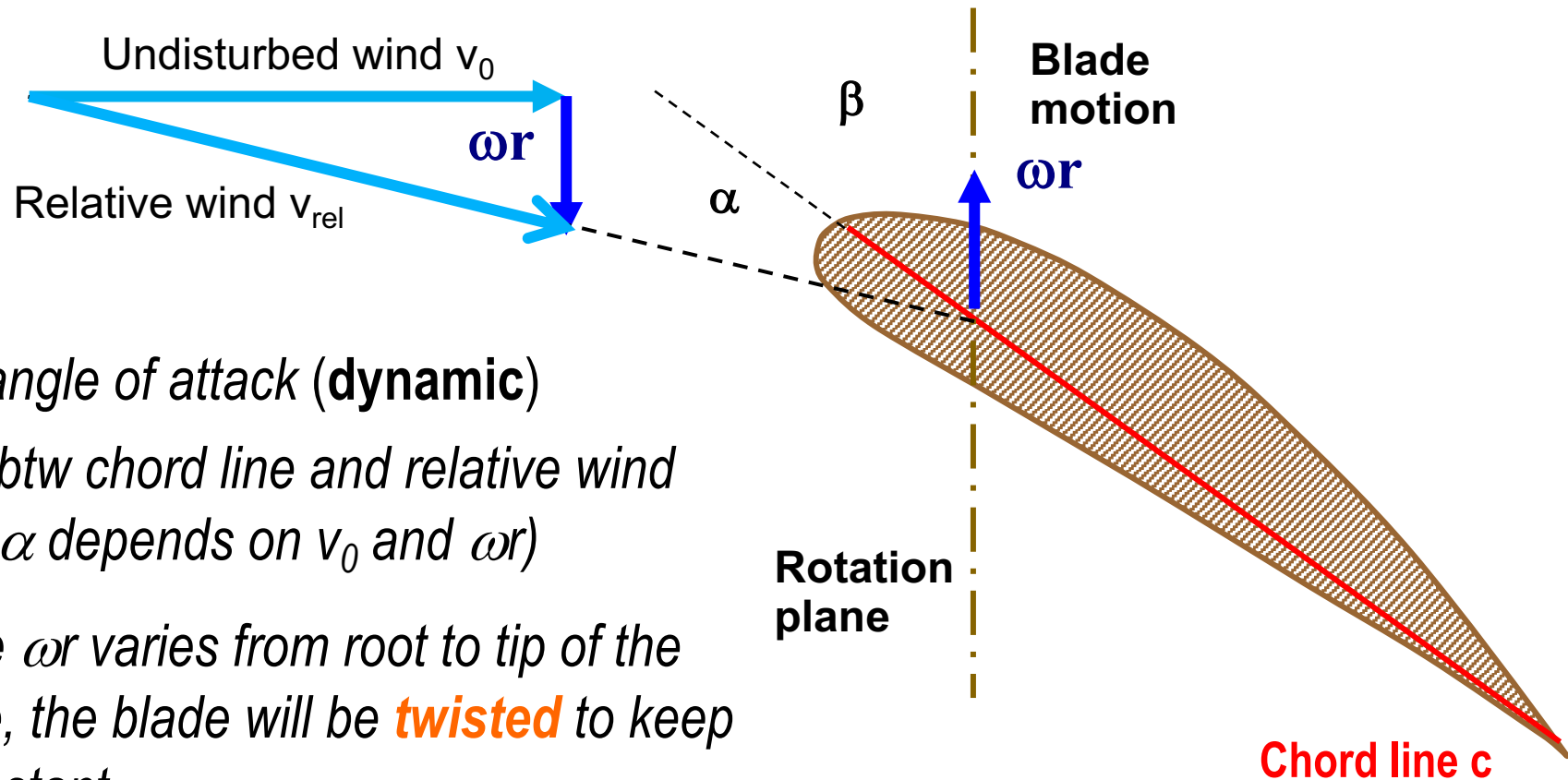

$\alpha$  : *angle of attack (dynamic)*  
= *btw chord line and relative wind*  
( $\alpha$  depends on  $v_0$  and  $\omega r$ )

Since  $\omega r$  varies from root to tip of the blade, the blade will be **twisted** to keep a constant  $\alpha$

$\beta$  : *pitch angle (static)*  
= *orientation of blade w.r.t. rotation plane*

# Torque and power

*Useful torque  $T$   
(net propelling force)*

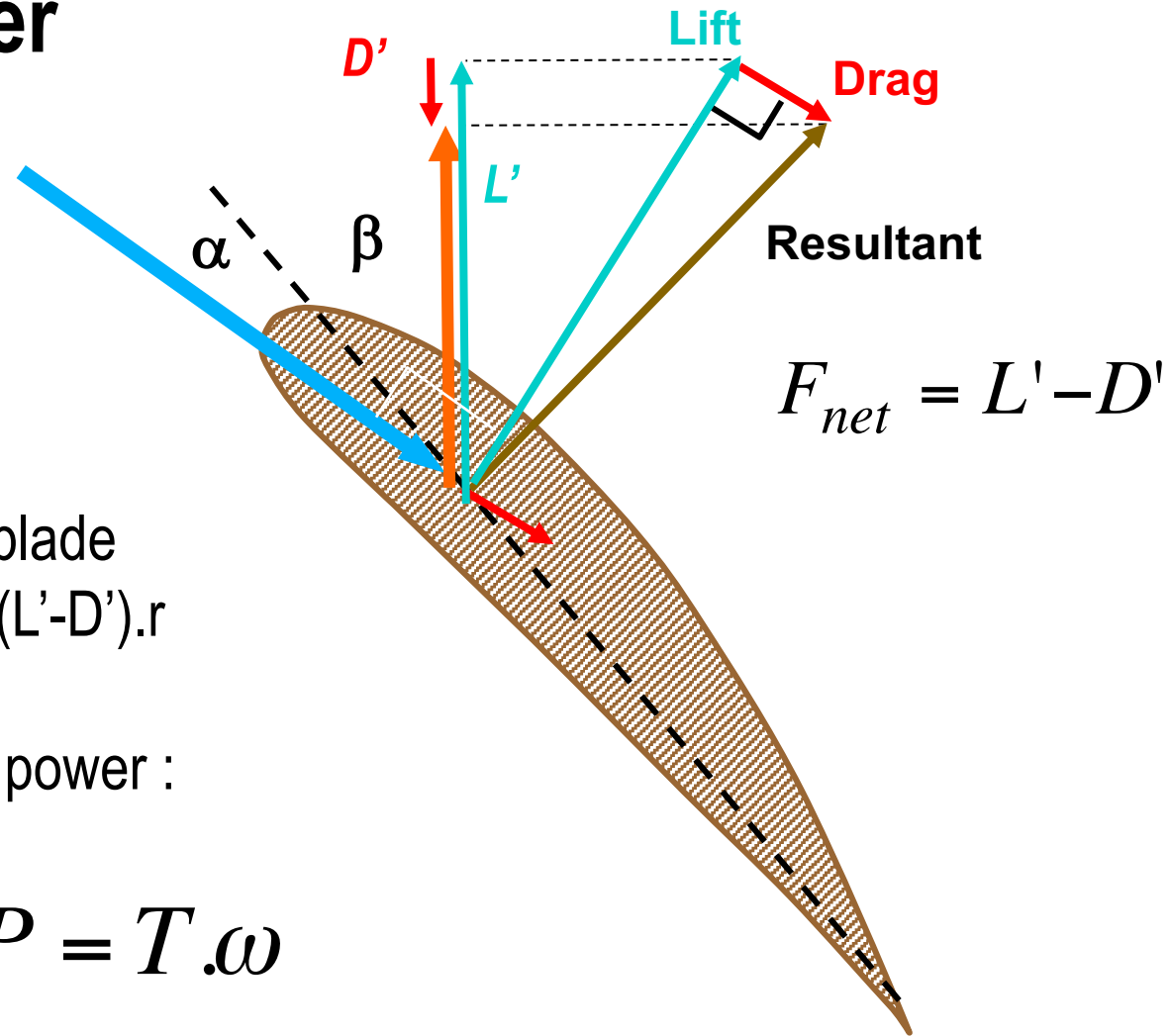

Contribution to **Torque** of blade element at radius  $r$  :  $\Delta T = (L' - D') \cdot r$

Total Torque of blade, and power :

$$T = \sum_{base}^{tip} \Delta T \quad P = T \cdot \omega$$

Let's now consider  $T-\omega$  and  $P-\omega$  characteristics of different turbines:  
LOW and HIGH *solidity*

# High solidity turbine $\frac{\sum \text{blades area}}{A} = \text{large}$ (multi-blade)

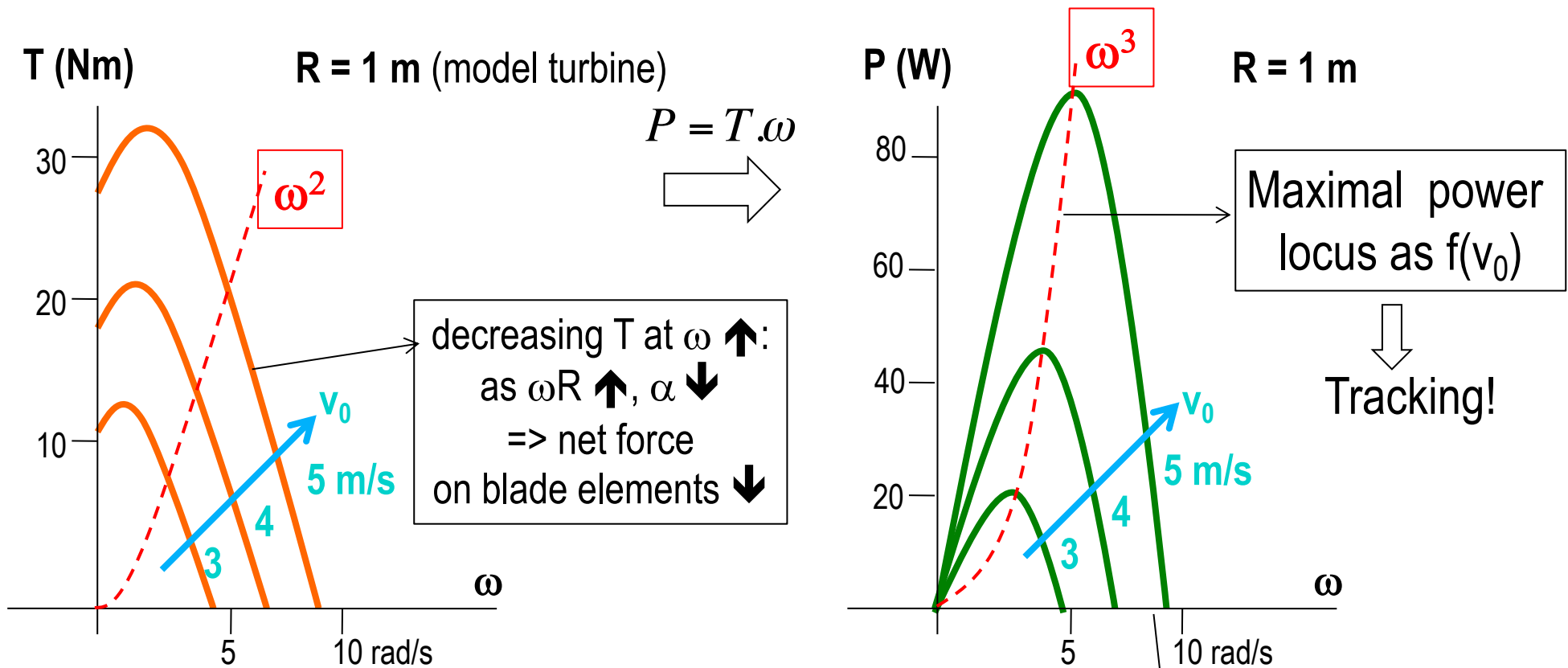

## High solidity

- $\rightarrow$  many blade elements contribute to  $T$  and  $P$
- $\rightarrow$  high starting torque (large mass, inertia)
- $\rightarrow$  low speed of rotation  $\omega$

# Low solidity turbine

$$\frac{\sum \text{blades area}}{A} = \text{small} \quad \text{(few blades)}$$

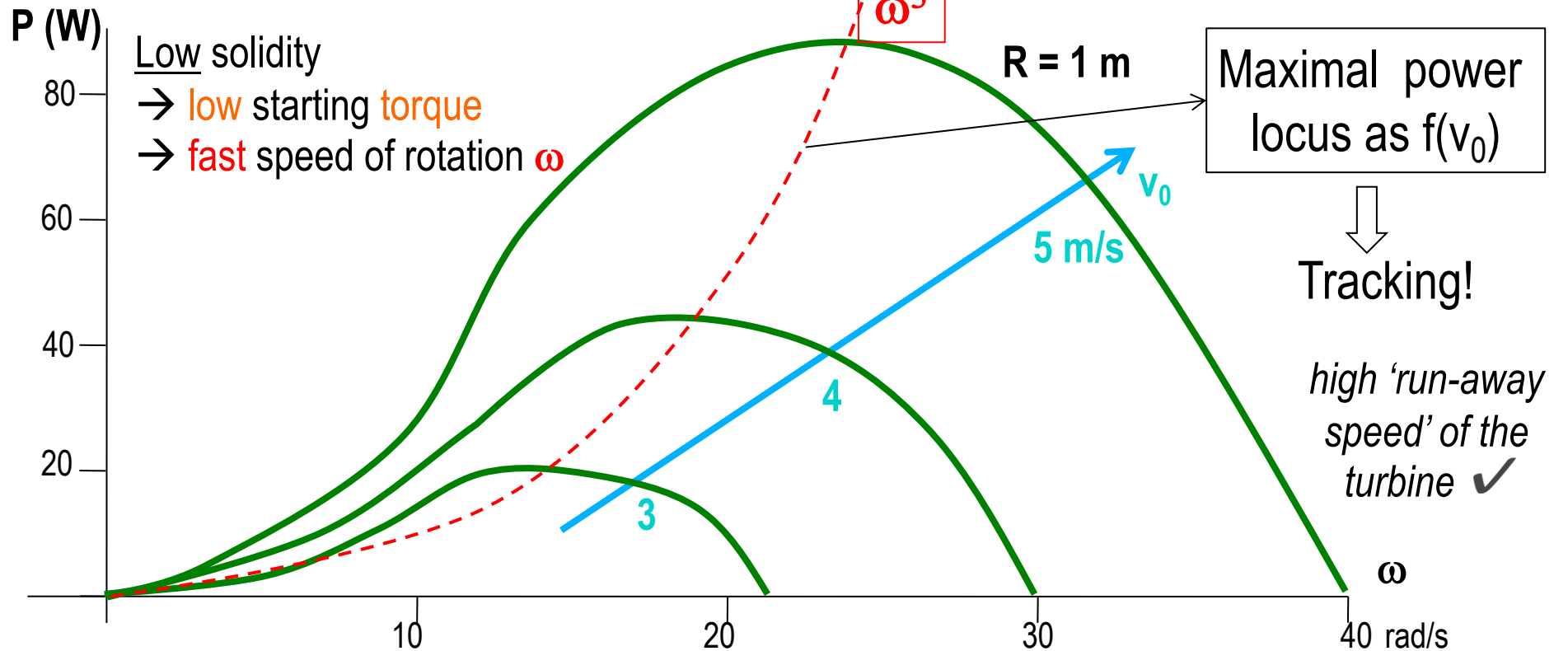
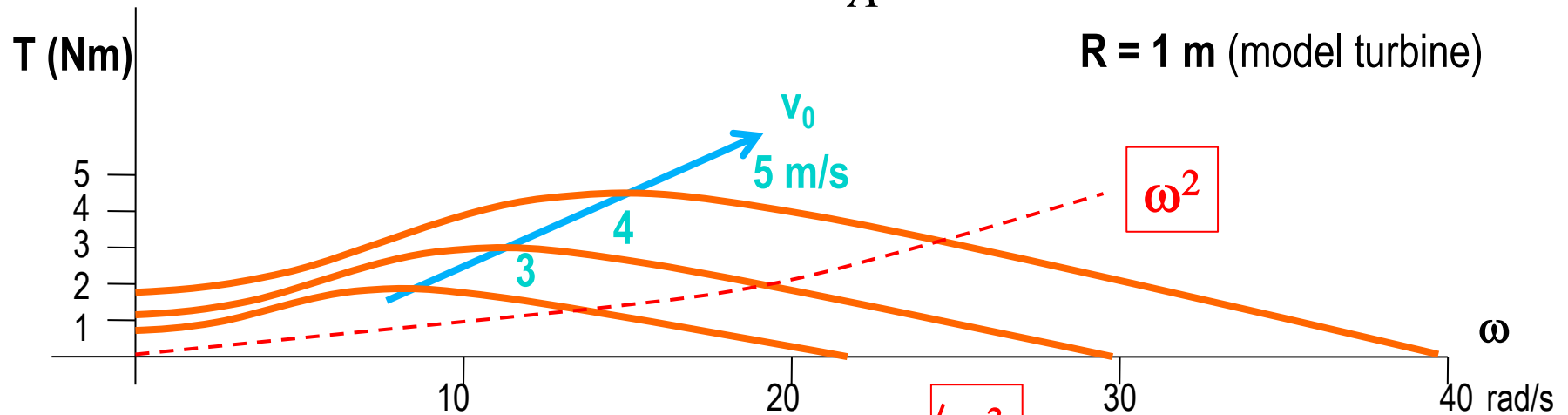

# Comments to T- $\omega$ , P- $\omega$ , for high/low solidity

- same power P for both turbines, but delivered at very different angular speed  $\omega$
- maximum power P is obtained at higher  $\omega$  than maximum torque T
- power maximum follows  $\omega^3$
- corresponding Torque follows  $\omega^2$
- for best load matching,  $P_{\max}$  should be tracked with variable wind speed (with a gearbox, to set  $\omega$  at the  $P_{\max}$  value for each  $v_0$ )
- In order to compare any turbines under different  $v_0$  and  $\omega$ , we 'normalise' according to

*Tip speed*  $\frac{\omega R}{v_0} = \lambda$   $\longrightarrow$  *Tip speed ratio*

wind speed  $\nearrow$

# Non-dimensional presentation of P- $\omega$ : $\rightarrow C_p - \lambda$

$$C_P = \frac{\dot{W}_T}{\dot{W}_W} = \frac{P}{\frac{1}{2} \rho_{air} A_T v_0^3}$$

$$\lambda = \frac{\omega R}{v_0}$$

$$T = \frac{P}{\omega}$$

For  $R > 1$  m,  $\omega$  will reduce for same  $\lambda$   
 $\Rightarrow$  hence large turbines rotate  
 at low  $\omega$  (few rad/s)

$$T = \frac{1}{2} \rho_{air} \pi R^2 v_0^2 \frac{C_p}{\lambda} R$$

**Force felt by the rotor disc area**

**Torque  $T = \text{Force } F * \text{radius } R$**

$$\frac{C_p}{\lambda} = \frac{T}{\frac{1}{2} \rho_{air} \pi R^2 v_0^2 R}$$

**Torque-coefficient**

# Summarising all $P-\omega$ for all $v_0$ into a single $C_p - \lambda$ curve

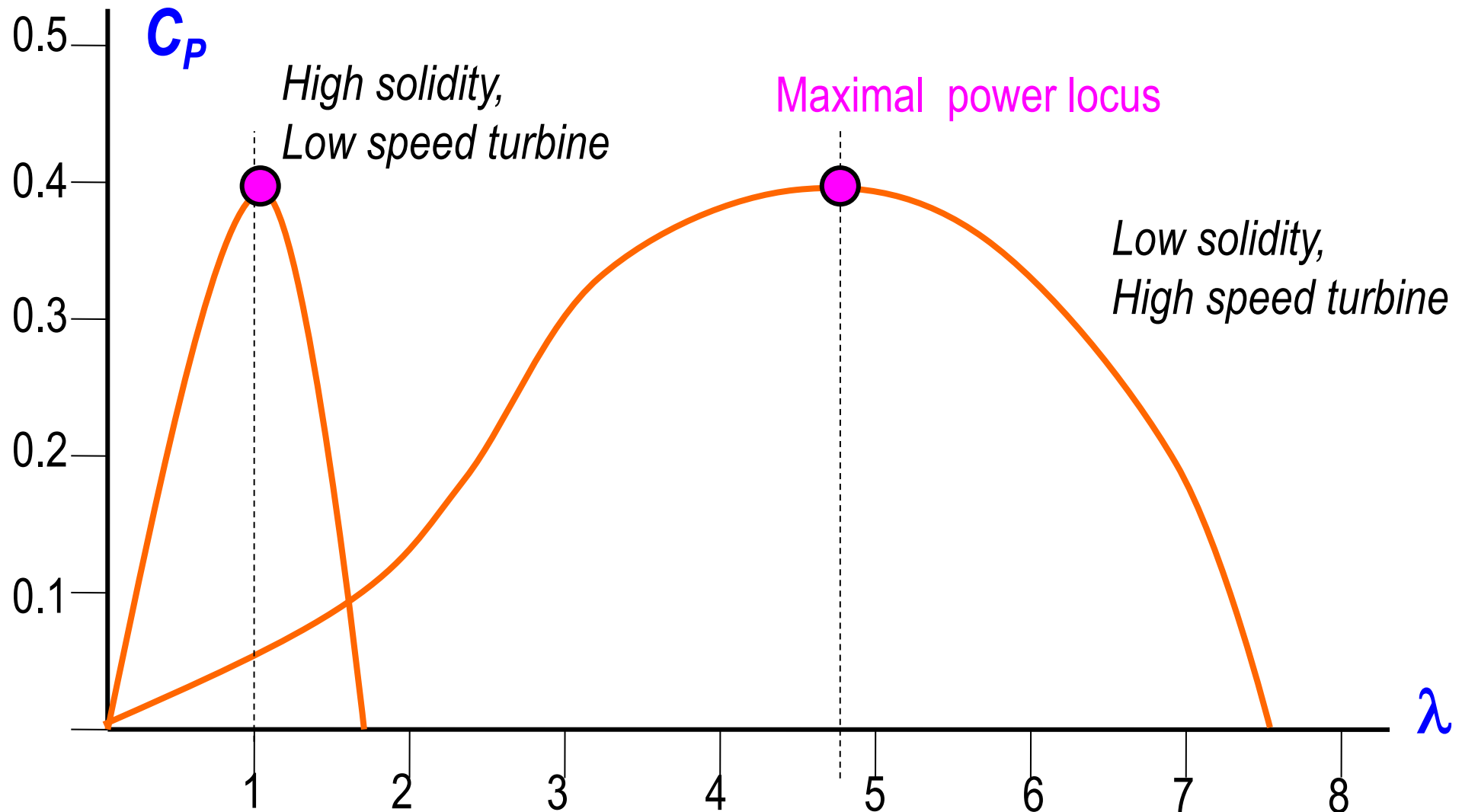

# Examples of $C_p - \lambda$ curve for different turbines

Rem. : high speed => less torque => less wake

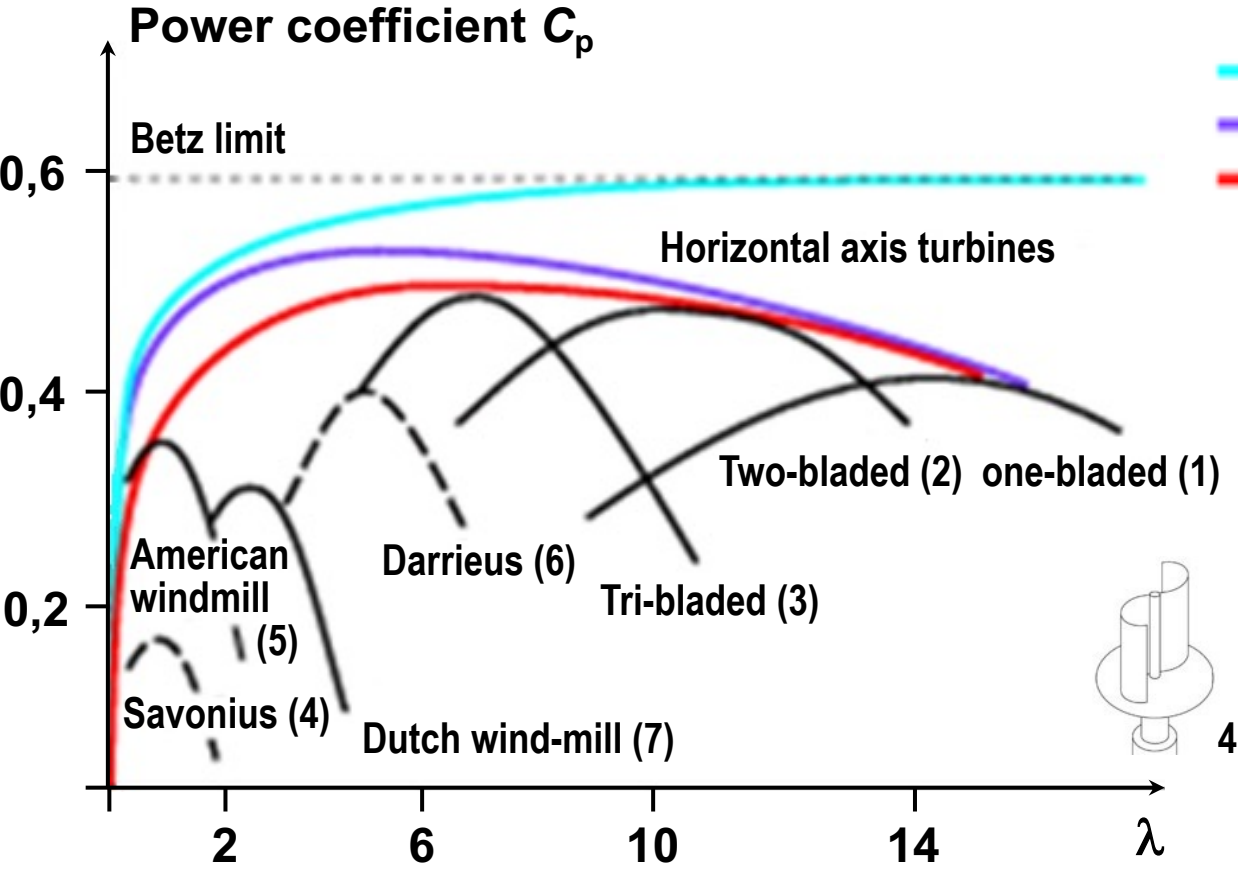

- Limits**
- with wake losses
  - with rotor drag losses
  - with a finite number of blades



# $C_p - \lambda$ curve with losses indicated

Performance of a typical modern 3-bladed turbine:

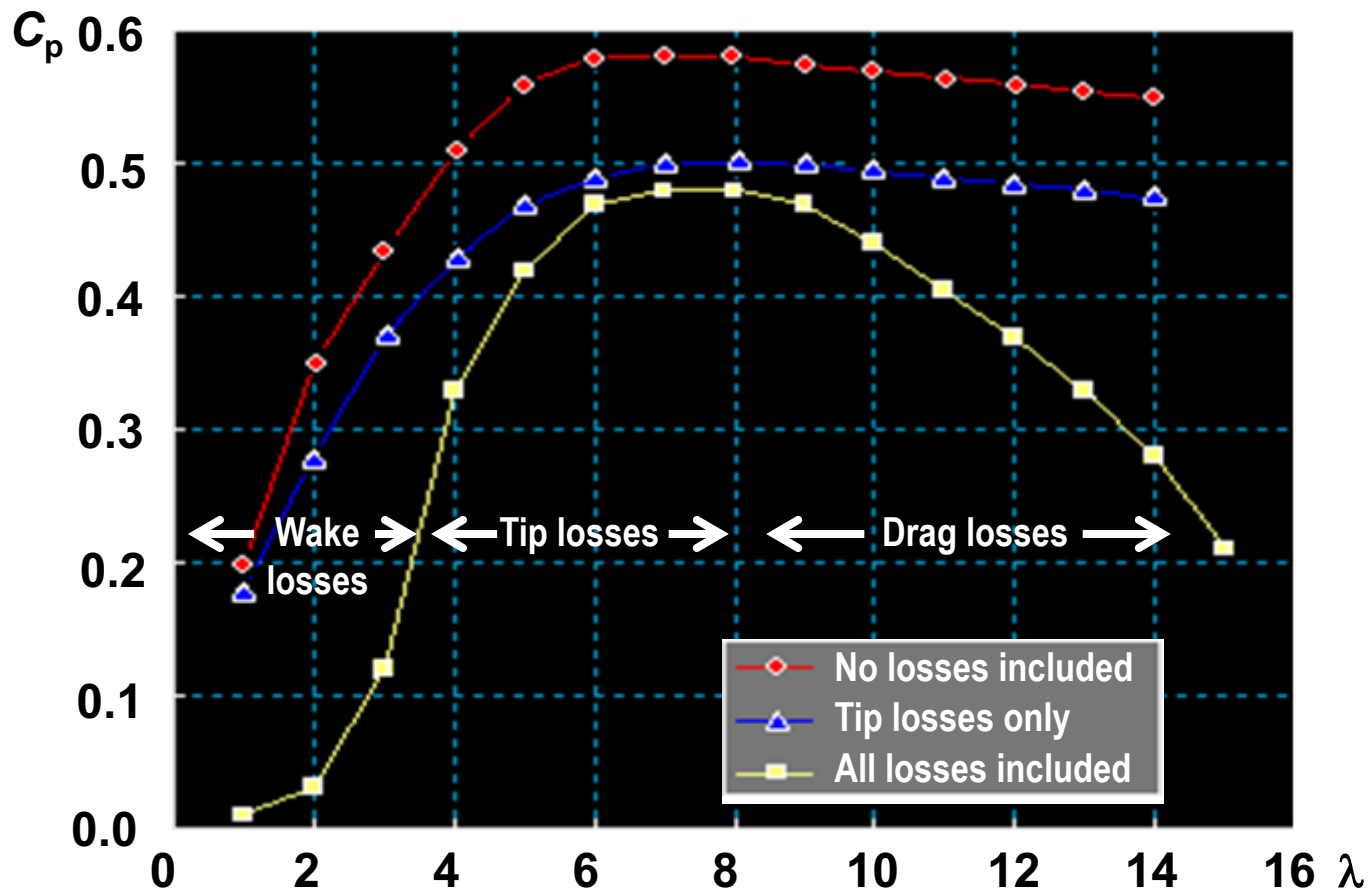

Note: even if no losses are included, the Betz-limit is not reached because the rotor design does not act as a perfect actuator disc.

$R$  : turbine blade radius  
 $v_0$  : wind speed  
 $\omega$  : turbine rotation speed

**Tip speed ratio:**

$$\lambda = \omega \cdot \frac{R}{v_0}$$

(typical  $\lambda = 8-9$  and max tip speeds = 80-90 ms/s)

# Lift and drag as $f(\alpha)$

$$K_L = a_0 \cdot \alpha$$

$$\frac{dK_L}{d\alpha} \approx 0.1 / ^\circ$$

*Lift-curve slope*

Reduces the lift,  
increases the drag

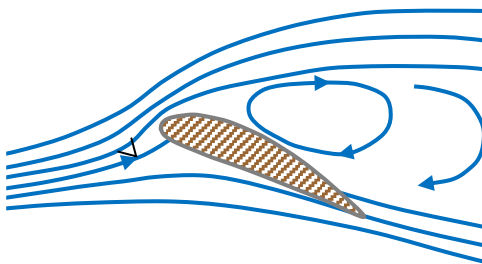

Stall

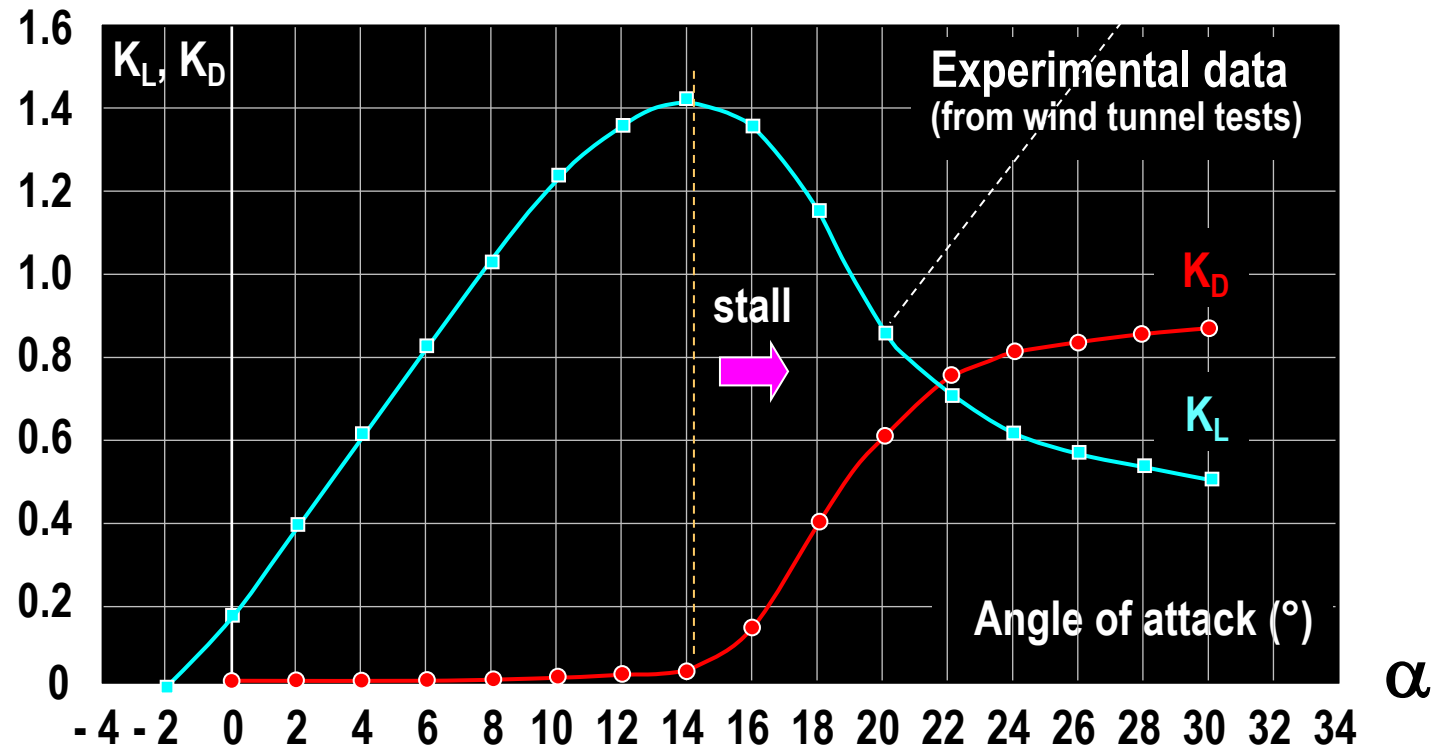

# Wind turbine blade design

Selection of the optimal angle of attack  $\rightarrow$  maximum lift, minimum drag, respecting the Betz criteria

Selection of the ideal  $\alpha$  angle is not easy, because  $K_L$  and  $K_D$  depend not only on the section but also on the Reynolds number RE:

$$RE = 68500 * \text{chord } c \text{ [m]} * \text{relat. wind veloc. } v_{\text{rel}} \text{ [m/s]}$$

**The optimal angle of attack generally occurs for values around 6-12°**

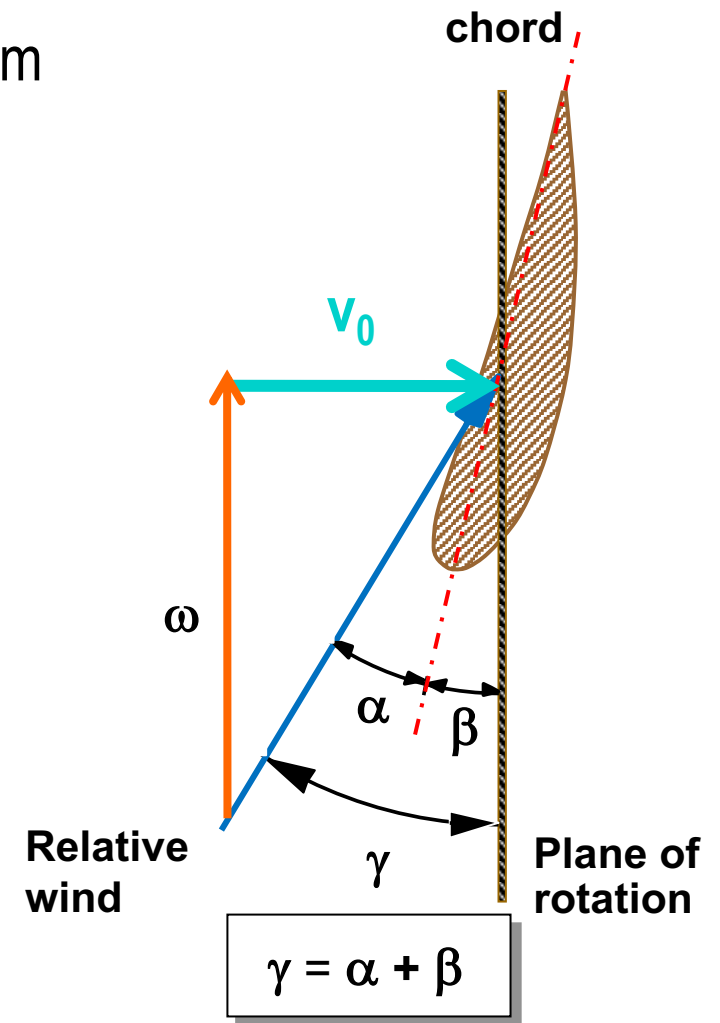

# Wind turbine blade design

$\alpha$  : *angle of attack (dynamic)*  
 = *btw chord line and relative wind*  
 ( $\alpha$  depends on  $v_0$  and  $\omega r$ )

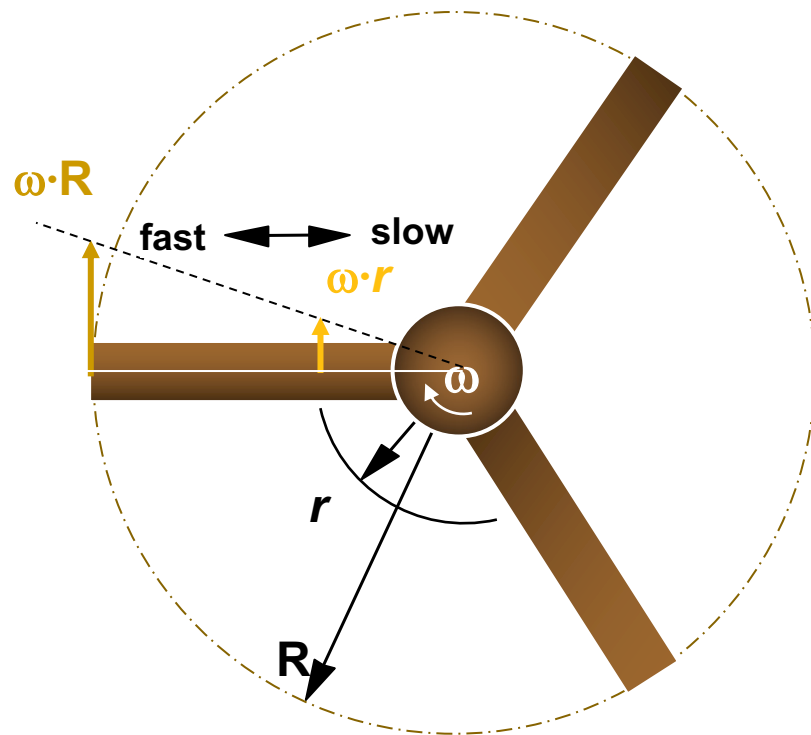

It follows that the optimal  $\gamma$  angle varies with  $r$  as:  $\gamma = \arctan(2R / 3r\lambda)$

Since  $\omega r$  varies from base to tip of the blade, the blades are twisted so as to maintain a nearly constant angle of attack.

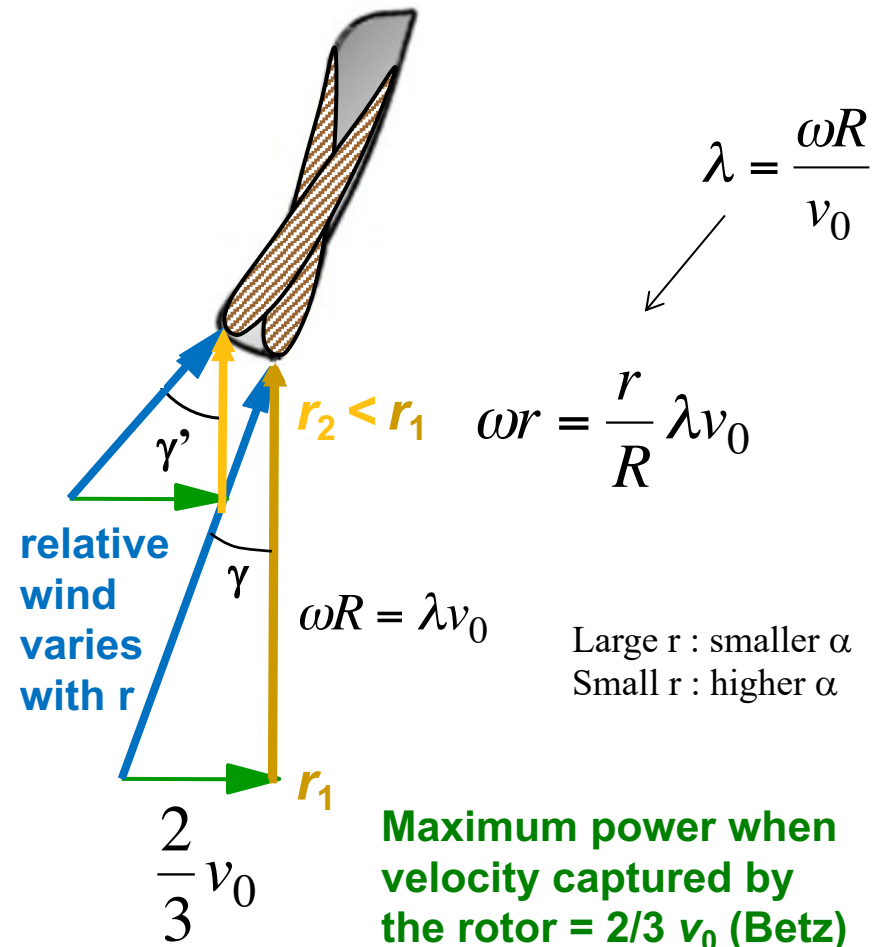

# Pitch angle $\beta$

The right pitch angle  $\beta$  is thus given by:

$$\beta = \gamma - \alpha = \arctang(2R/3r\lambda) - \alpha$$

Forces acting on the wind turbine:

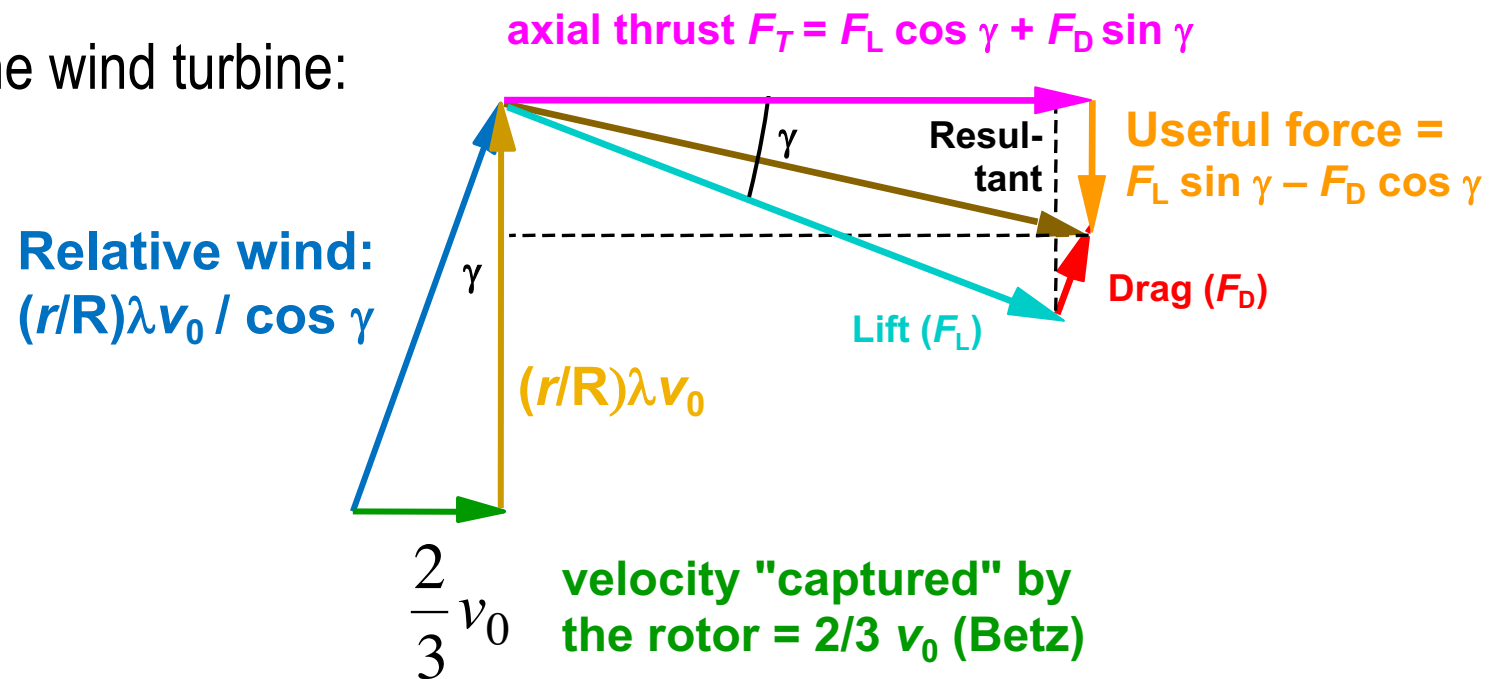

# Blade design

A blade element of width  $\Delta r$  sweeps a “wind band” of area  $2\pi r\Delta r (=A_r)$

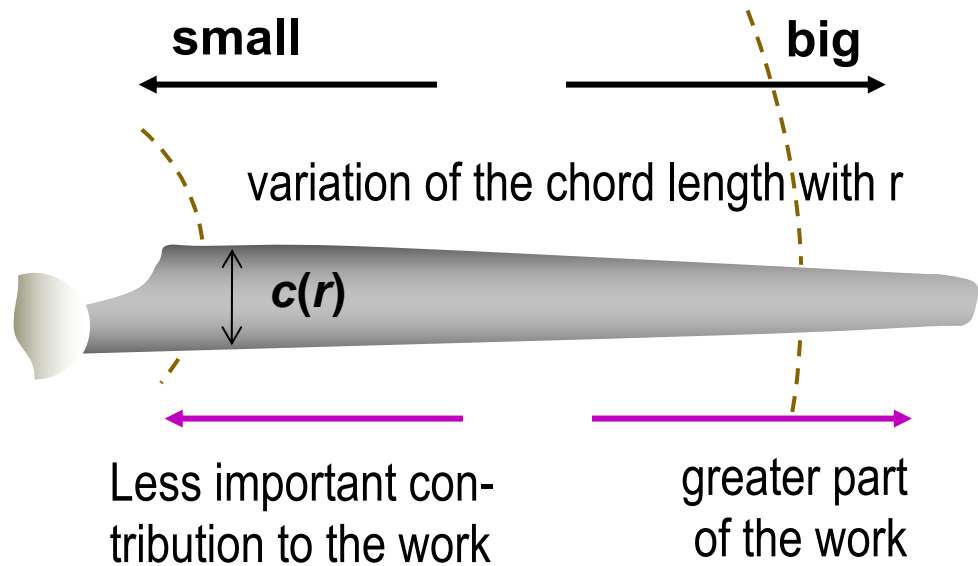
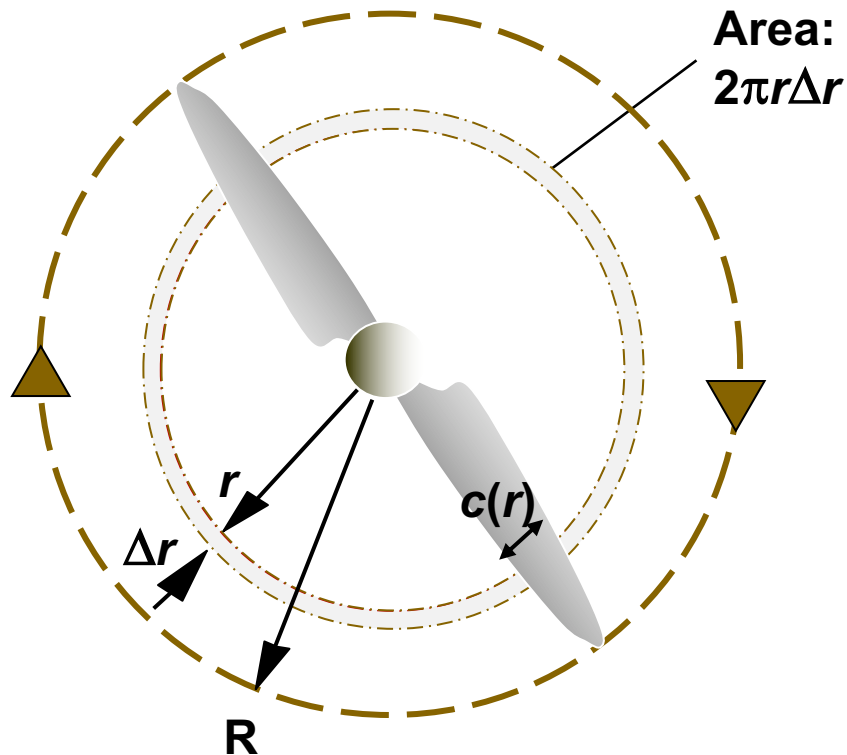

For the Betz condition, the axial thrust exerted by the wind on the propeller is given by (rate of change of momentum):

$$F_T(r) = \rho \underbrace{A_r}_{(v_0+v_2)/2} \underbrace{v_T}_{1/3 v_0} (v_0 - v_2) = \frac{4}{9} \rho (2\pi r \Delta r) v_0^2$$

$(2/3 v_0) \cdot (2/3 v_0)$

cf. slide 55;  
EQUATION (i)

# What is the optimal chord length $c(r)$ ?

On the other hand :  $F_T = F_L \cos \gamma + F_D \sin \gamma$  → small solidity

with  $F_L(r) = K_L \frac{1}{2} \rho S_r v_{rel}^2 = K_L \frac{1}{2} \rho \underbrace{Nc(r)\Delta r}_{\text{tot. surface of the N blades at } r} v_{rel}^2$  N: number of blades  
cf. slide 67;  
EQUATION (ii)

Taking the EQUATIONS (i) and (ii) for  $F_T$  :

$$\Rightarrow F_T(r) = \frac{4}{9} \rho (2\pi r \Delta r) v_0^2 = K_L \frac{1}{2} \rho Nc(r)\Delta r v_{rel}^2 \cos \gamma$$

$(r/R)\lambda v_0 / \cos \gamma$

$$\Rightarrow c(r) = \frac{16 \pi R^2}{9 N r K_L \lambda^2} \cos \gamma$$

*Ideal* chord length  $c(r)$  :

- invers. prop. to  $r \Rightarrow$  *tapered blade*
- invers. prop. to the blades number  $N$   
 $\Rightarrow$  *more blades, more narrow*
- invers. prop. to the square of the tip speed ratio

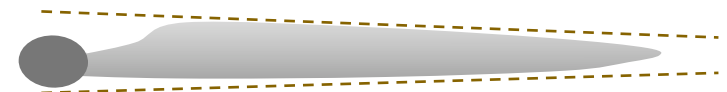

# → Theoretical design of ideal wind turbine:

## Infinite number of infinitely narrow blades!

= impossible in practice, for strength and mechanical stiffness reasons, as well as for the resulting too low rotation speed (high solidity). On the other hand, a high tip speed ratio implies a *larger rotation speed*, which is more favourable in the context of electricity generation (gearbox → 3000 rpm = 50 Hz grid) and overrides the disadvantages, which are:

- relatively high noise level generated by the blades (high speed)
- erosion of the leading edge (=“front”) of the blades
- lower efficiency
- less favourable *starting torque* (with higher  $\lambda$ )

$$T = \frac{1}{2} \pi \rho_{air} C_p \frac{v_0^2 R^3}{\lambda}$$

The shape adopted for the wind turbine blades is finally the following:

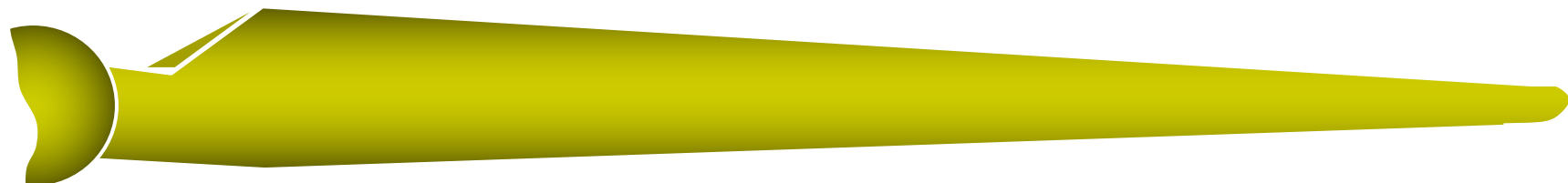

Enlarged blade root to make start easier

Rounded tip to reduce the noise

# Operating range

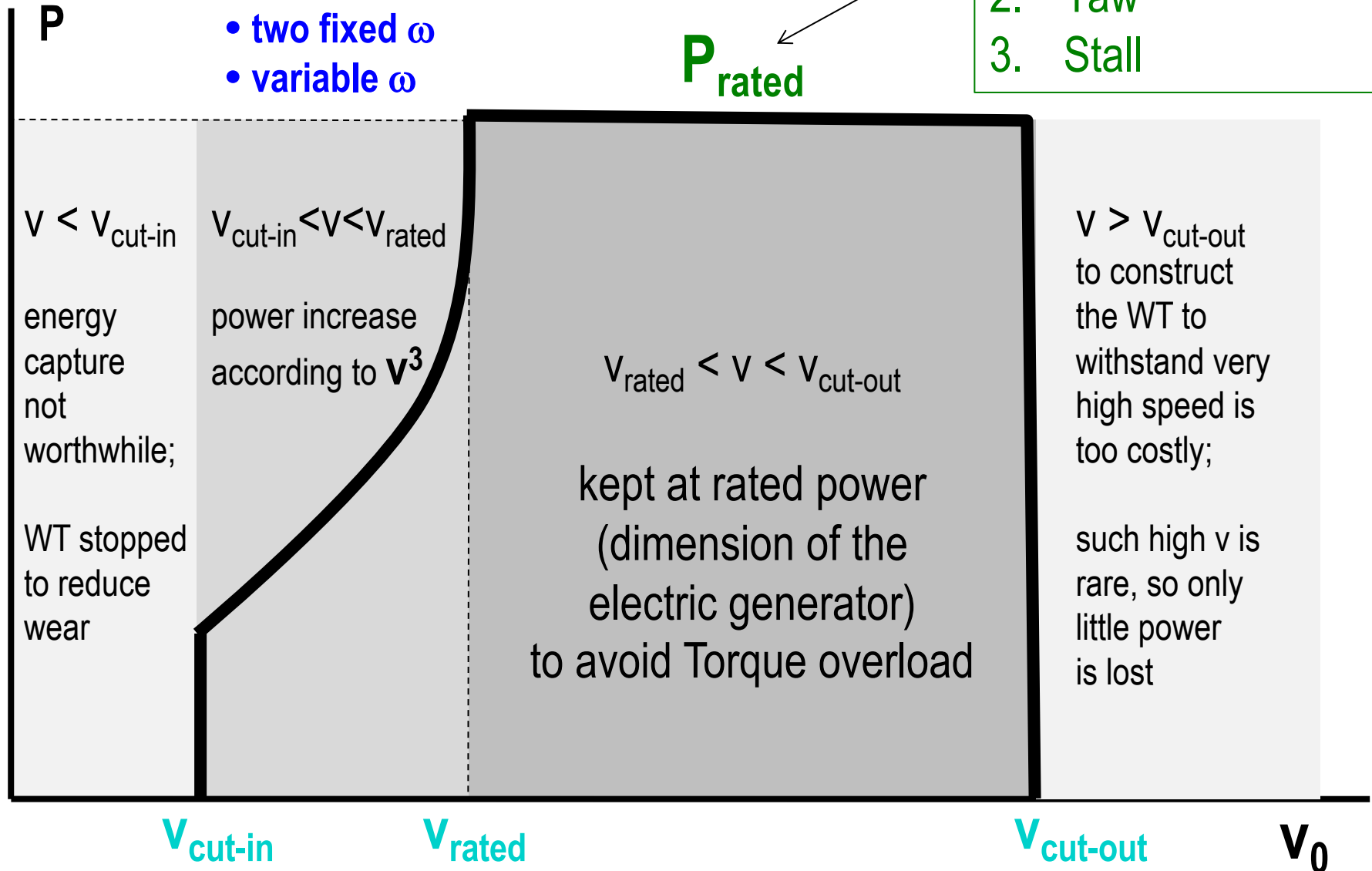

- WT is run at:
- one fixed  $\omega$
  - two fixed  $\omega$
  - variable  $\omega$

- Aerodynamic power limiting regulation by:
1. Variable pitch  $\beta$
  2. Yaw
  3. Stall

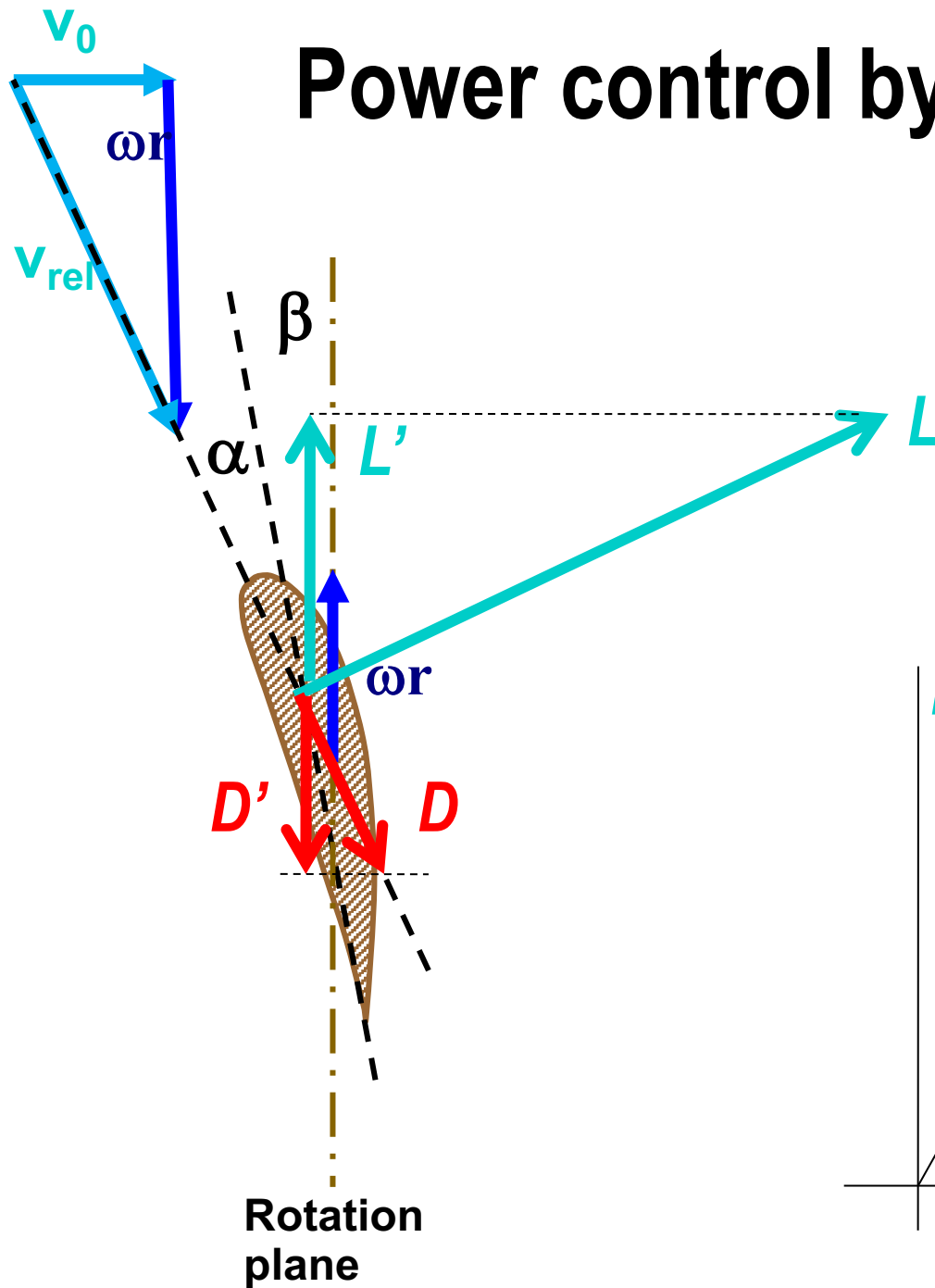

# Power control by variable blade pitch



- 
**FINE:**  $0 < \beta < 5^\circ$   
 $v_{cut-in} < v < v_{rated}$
- 
**PART-FEATHER:**  
 $v_{rated} < v < v_{cut-out}$
- 
**FULL-FEATHER or COARSE:**  
 $\beta = 90^\circ \quad v > v_{cut-out}$

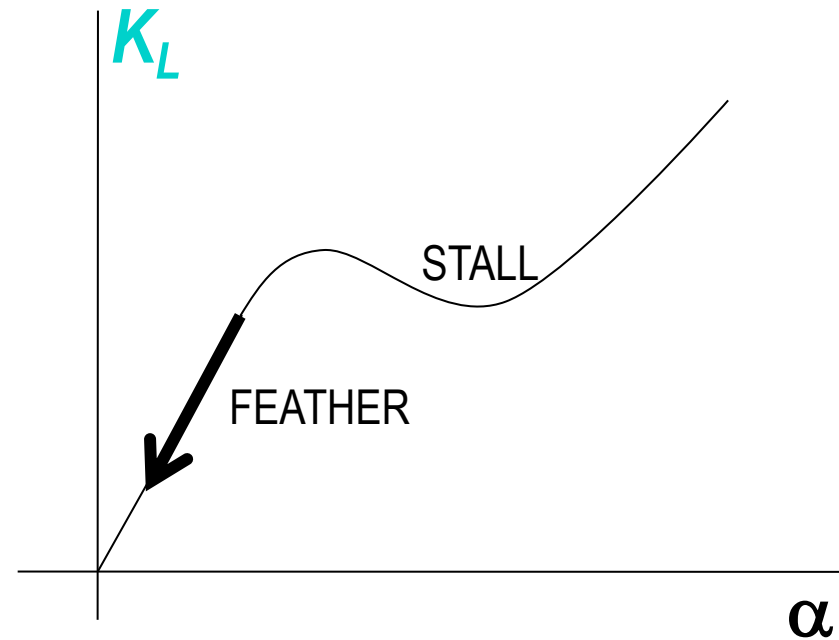

# Power control by stall regulation

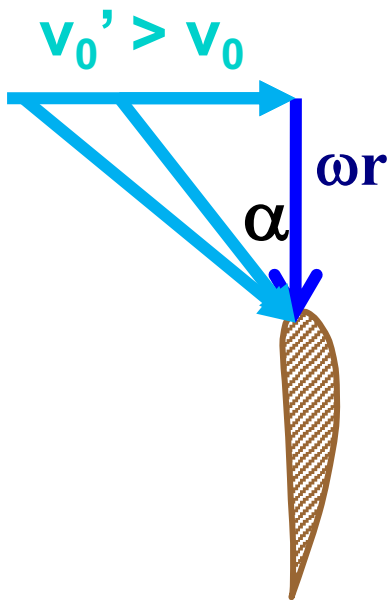

Pitch  $\beta$  is fixed in FINE  
 $\omega$  is fixed

When  $v_0 \uparrow$ ,  $\alpha \uparrow$   
 $\Rightarrow$  LIFT  $L \downarrow$   
 $\Rightarrow$  DRAG  $D \uparrow$

Stall regulation is achieved through proper design of blades **twist** and **thickness**, **low  $\omega$** , and low chord  $c$ . Simple and cheap (no moving blades).

## Disadvantages:

- some energy loss
- no assisted start (no pitch control)  
(starts only at high  $v_0$ )
- high stationary load (fixed in FINE)
- separate brake needed to prevent overspeed
- stall depends on blade surface condition

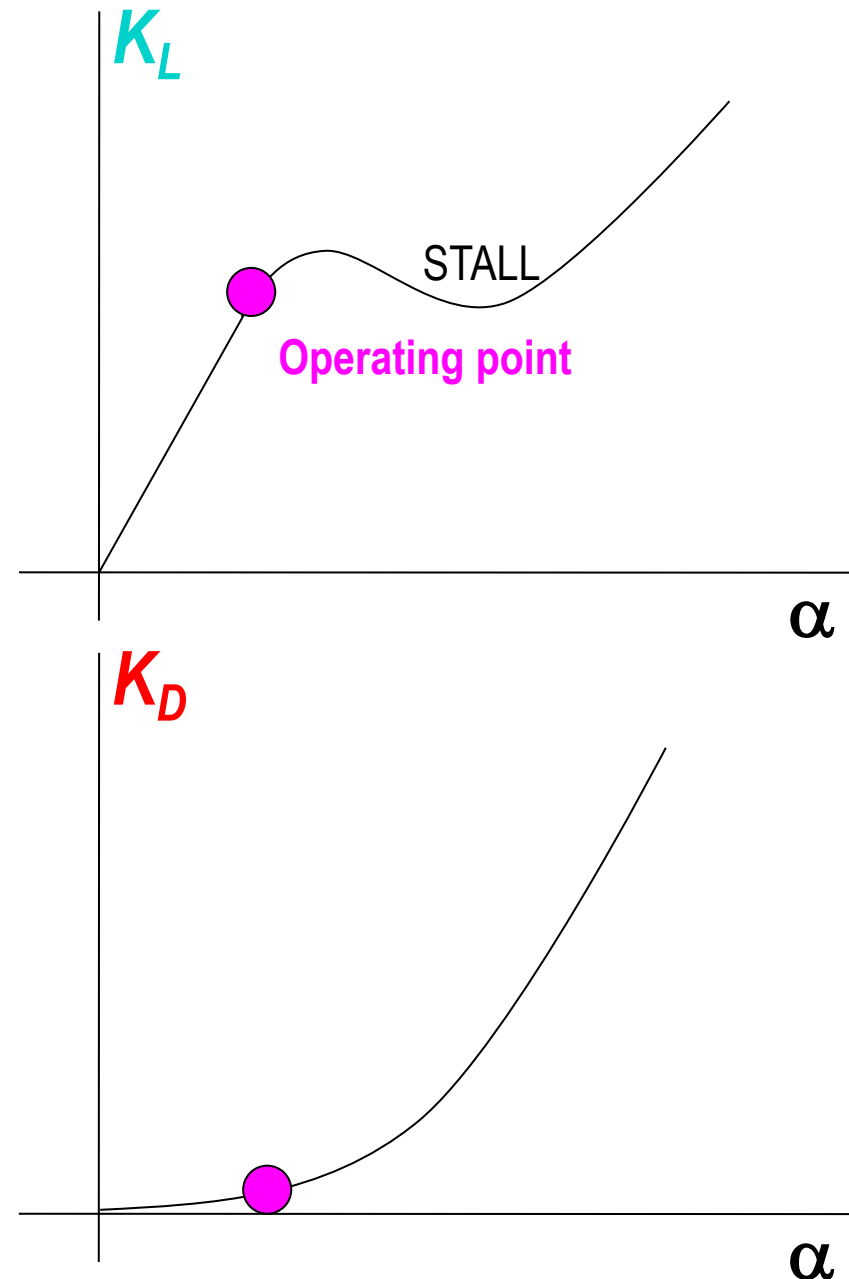

# Fixed speed operation

- = the majority of wind turbines
- minimal hardware and complexity ✓
- high reliability ✓
- but: does not capture the maximal energy

- How to determine optimum  $v_{\text{cut-in}}$ ,  $v_{\text{rated}}$ , and  $v_{\text{cut-out}}$  ?

- How to determine  $\omega$  ?

→ need to find  $\lambda_{\text{optimal}} = \frac{\omega R}{N v_{\text{avg}}}$  where  $C_p$  is highest

(N relates to the optimal gearbox ratio: N = the multiple of the site-average windspeed  $v_{\text{avg}}$  for which the turbine runs at optimum  $\lambda$ . Knowledge of N gives  $\omega$  = the turbine rotation speed)

- The answer will depend on:  $C_p$ - $\lambda$  curve, Weibull shaping factor k

- Efficiency =  $E/E_{\text{max}}$ , where  $E_{\text{max}}$  is achieved when  $C_p = C_{p,\text{max}}$ ,

$v_{\text{cut-in}} = 0$ , and  $v_{\text{cut-out}} = \infty$

# Efficiency with fixed speed operation

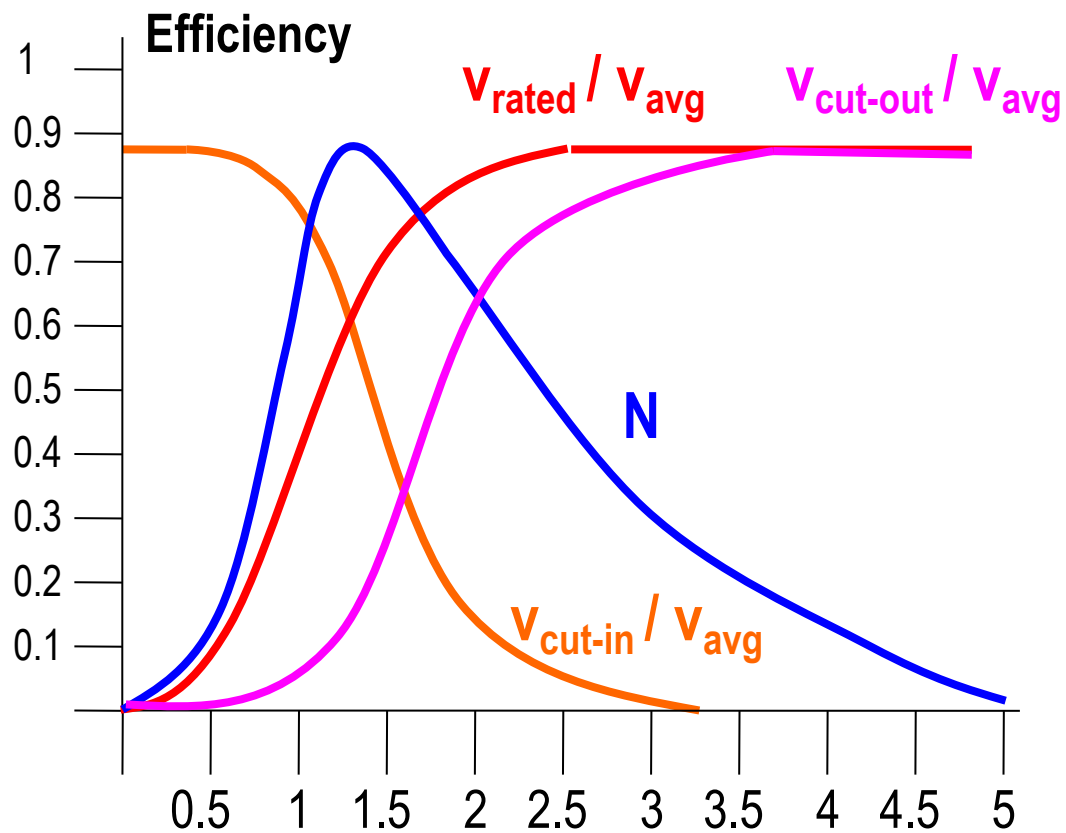

Best parameter choice:

$$V_{\text{cut-in}} = 0.6 V_{\text{avg}}$$

$$V_{\text{rated}} = 2 V_{\text{avg}}$$

$$V_{\text{cut-out}} = 3 V_{\text{avg}}$$

$$N = 1.5$$

Example :

$$V_{\text{avg}} = 8 \text{ m/s}, R = 15\text{m}, \lambda_{\text{optimal}} = 6$$

$$V_{\text{cut-in}} = 4.8 \text{ m/s}$$

$$V_{\text{rated}} = 16 \text{ m/s}$$

$$V_{\text{cut-out}} = 24 \text{ m/s}$$

$$N = 1.5$$

$$\lambda_{\text{optimal}} = \frac{\omega R}{N V_{\text{avg}}} \Rightarrow \omega = 4.8 \text{ rad/s} = 46 \text{ rpm (will be the fixed rotation speed)}$$

For 4-pole 50 Hz connection (=3000 rpm with 2-pole, 1500 rpm with 4-pole):

$$\Rightarrow \text{gearbox ratio} = 1500 / 46 = 33$$

# Variable speed operation

- higher cost
- less reliability
- **captures 7% more energy** than with fixed speed operation
- lower  $v_{\text{cut-in}}$ ; less noise at low  $v_0$ ; operating at lower  $\omega$  at night-time
- $C_{p,\text{max}}$  is maintained over a range of  $v_0$
- **less power fluctuations** (better electricity supply quality):
  - with *fixed speed* operation ( $\omega=\text{const}$ ), wind gust energy ( $P=\omega.T$ ) is recorded as Torque  $\rightarrow$  Power (prop.  $v^3$ )  $\rightarrow$  grid injection (leading to 'flicker')
  - with *variable speed* operation, wind gust energy goes into higher rotation speed  $\omega$  and reduced Torque, keeping power constant  $\rightarrow$  constant elec. output injected in grid
  - nonetheless, injected current is richer in harmonics (100, Hz, 150 Hz, 200 Hz) which need to be filtered, increasing filter cost

# Wind turbine designs

Two big families:

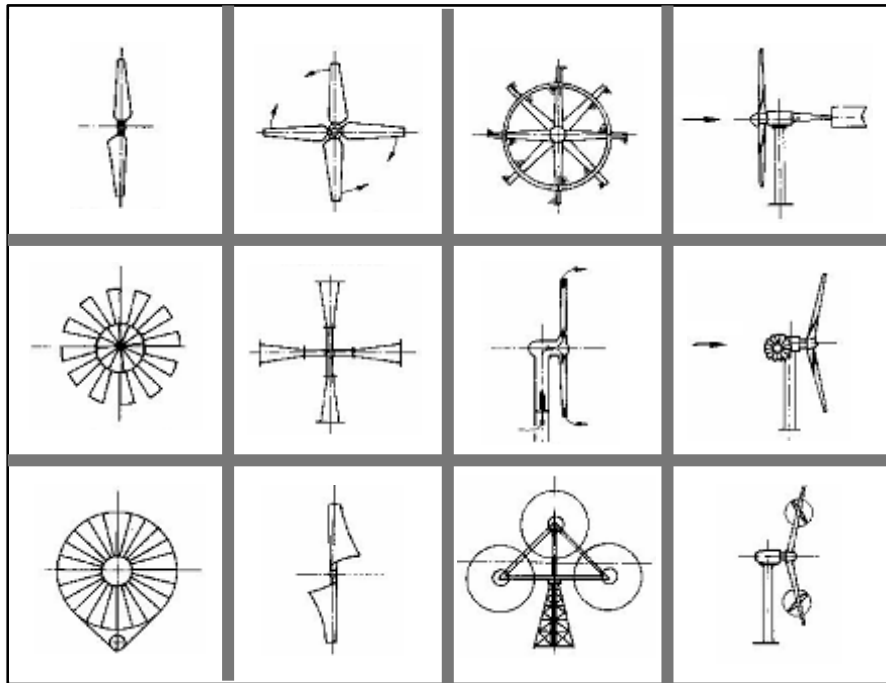

Horizontal  
Axis  
(HAWT)

subfamilies

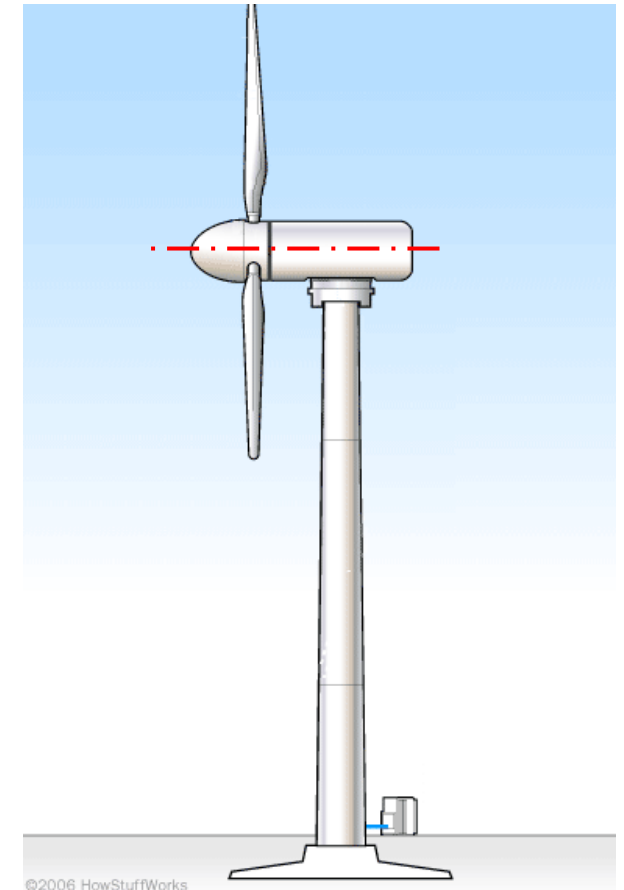

# Wind turbine designs

Two big families:

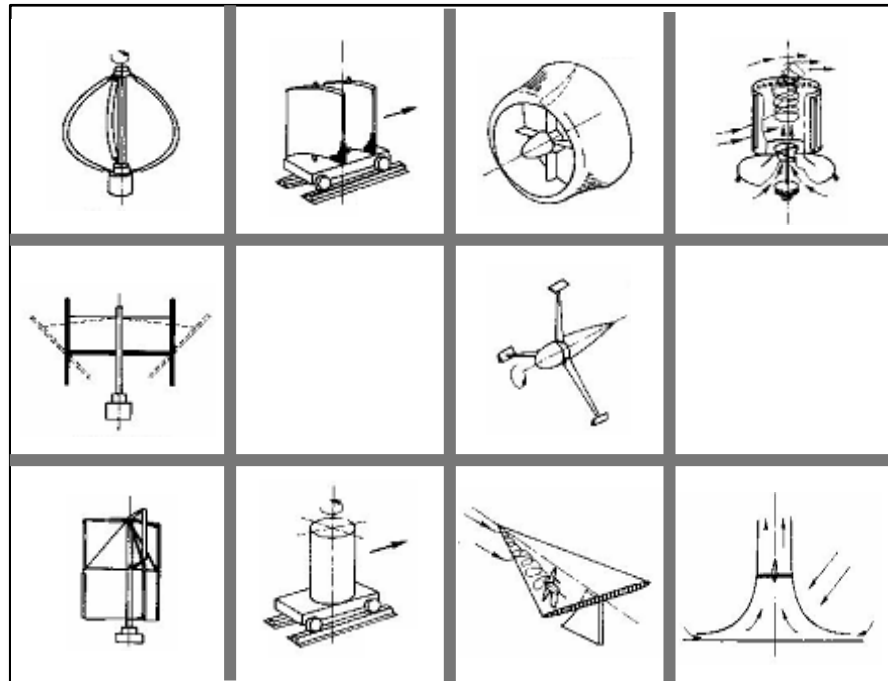

**Vertical** Axis  
(VAWT)  
and  
others

subfamilies

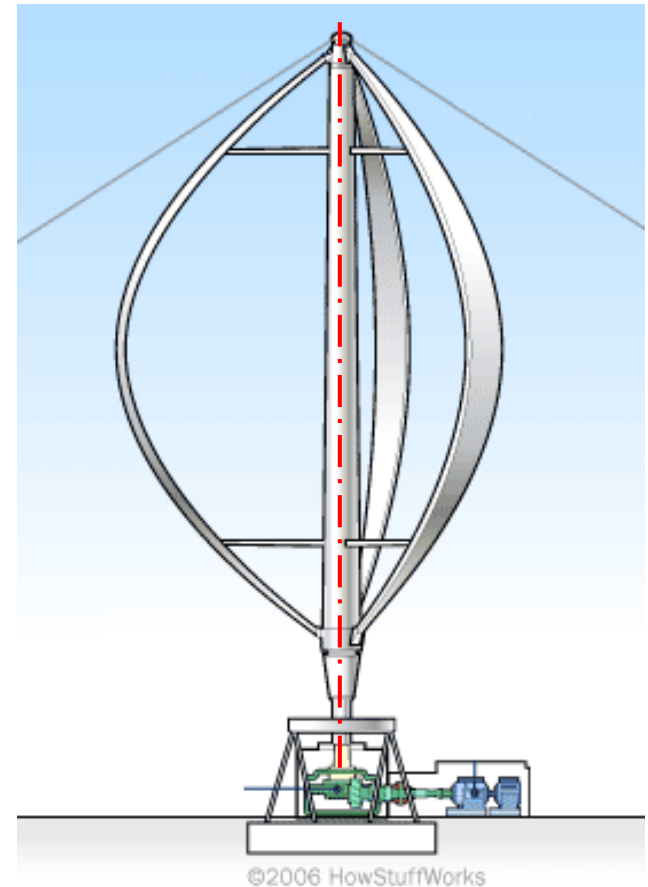

# HAWT designs

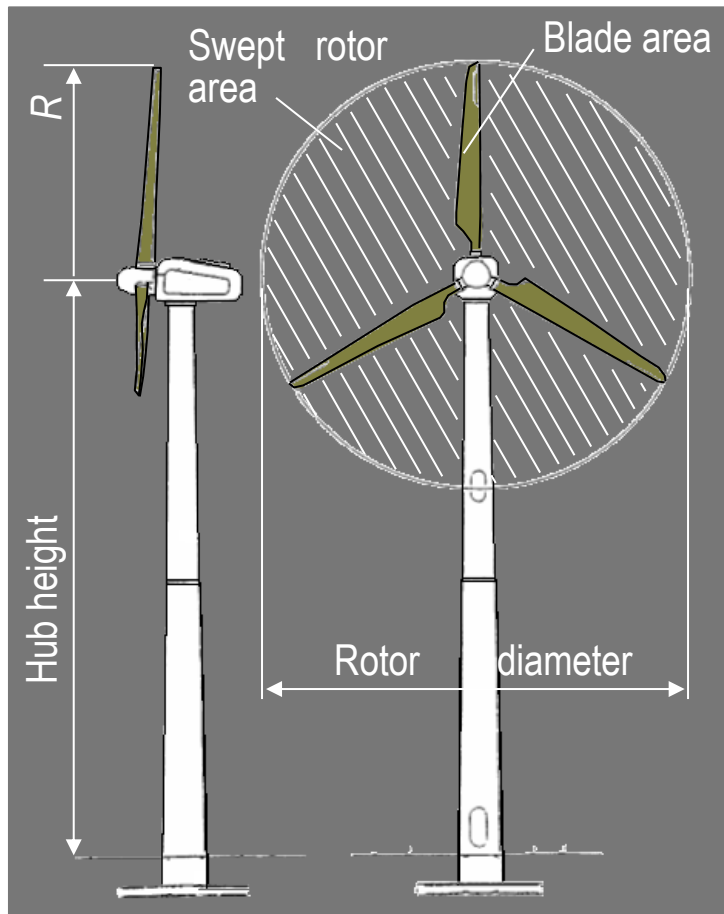

Parameters :

Rated Power → Maximum continuous power output that the turbine is designed to deliver at the electrical connection point

Hub Height → Height of the hub above ground

Swept area → Area swept by the rotor blades

Solidity → The ratio of the area of the blades to the swept area

$$\text{Solidity} = \frac{\text{Blades area}}{\pi \cdot R^2}$$

# HAWT design – main components

1. Rotor blade

2. Rotor shaft

3. Gearbox

4. Generator coupling

5. Generator

6. Hub

7. Rotor bearing

8. Disk brake

9. Wind measuring syst.

10. Control system

11. Yaw drive

12. Nacelle

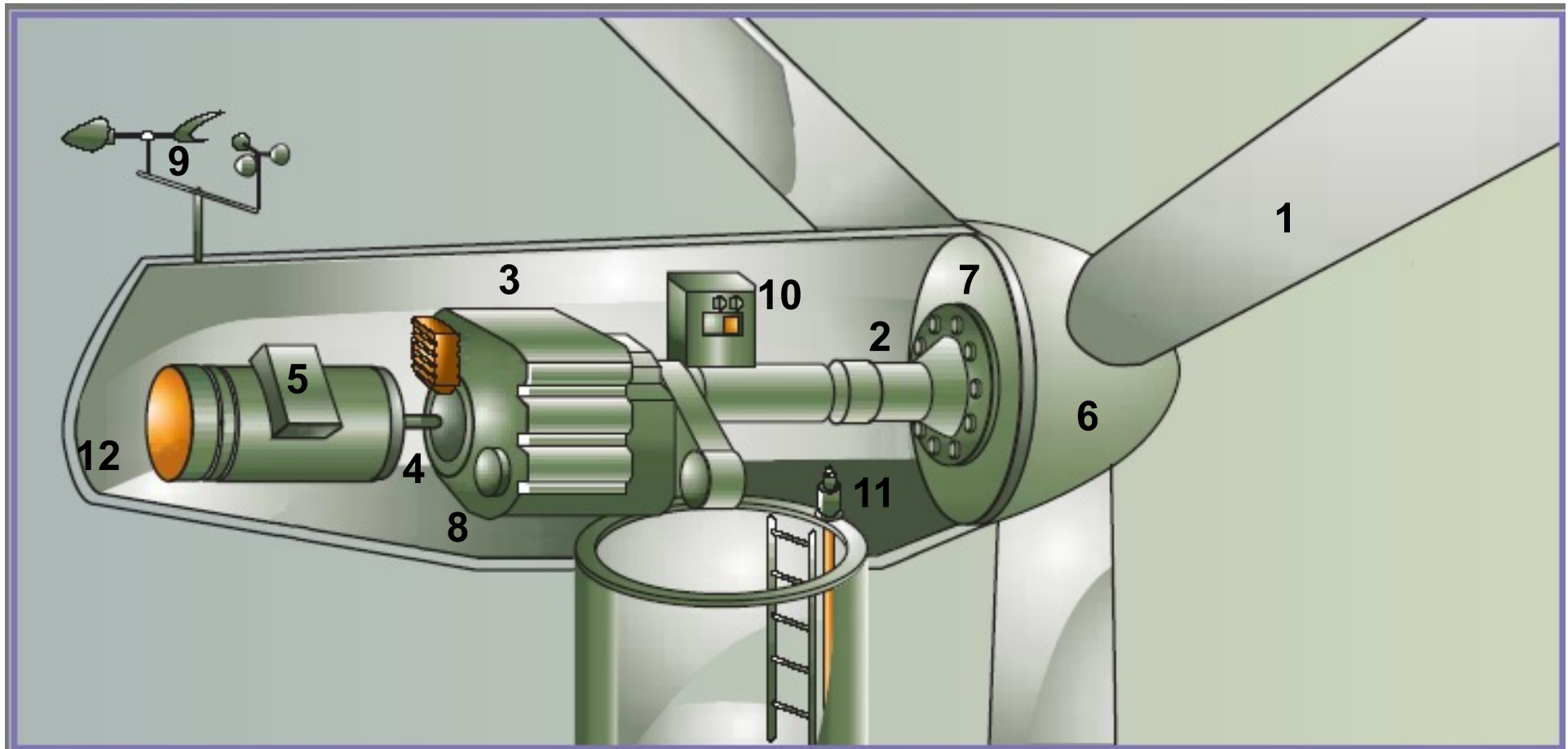

# HAWT : the rotor

glass rein-forced plastic (GRP) / wood and wood laminate / carbon fibre reinf. plastic (CFRP) / aluminium / steel

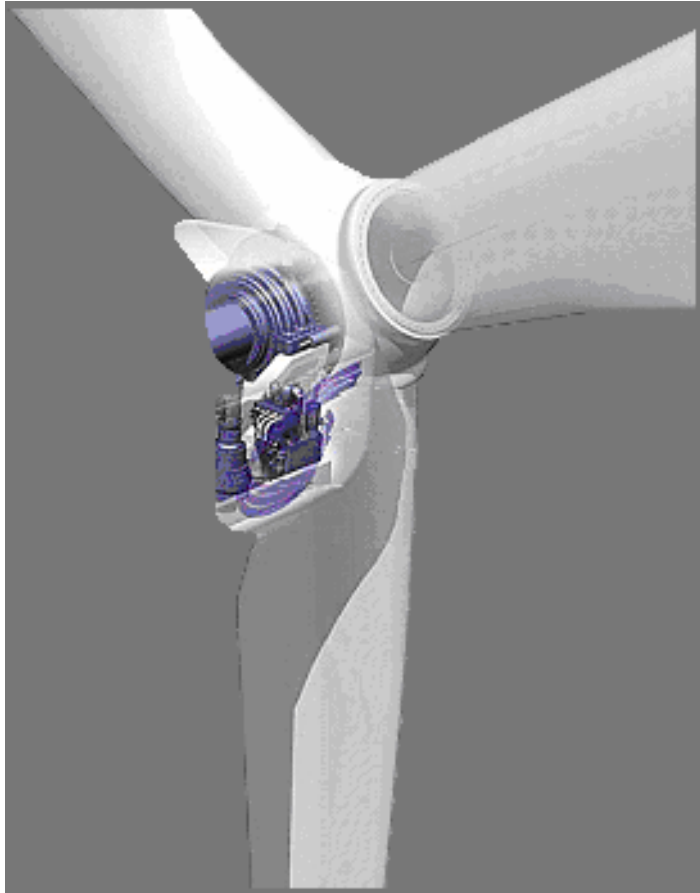

The rotor assembly may be placed either:

- *Upwind* of the tower (→ wind relatively undisturbed by the tower itself) or
- *Downwind* of the tower, which enables self-alignment of the rotor with the wind direction (→ wind made turbulent by the tower before arriving at the rotor: *tower shadow*)

In pitch-regulated turbines the angle of the blades can be varied; this results in reduction of blade effectiveness and maintenance of rated power even if the wind speed is above rated

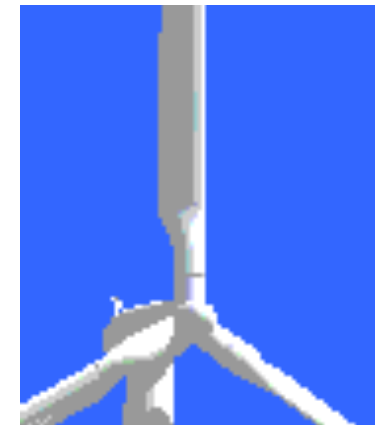

# HAWT: the transmission system

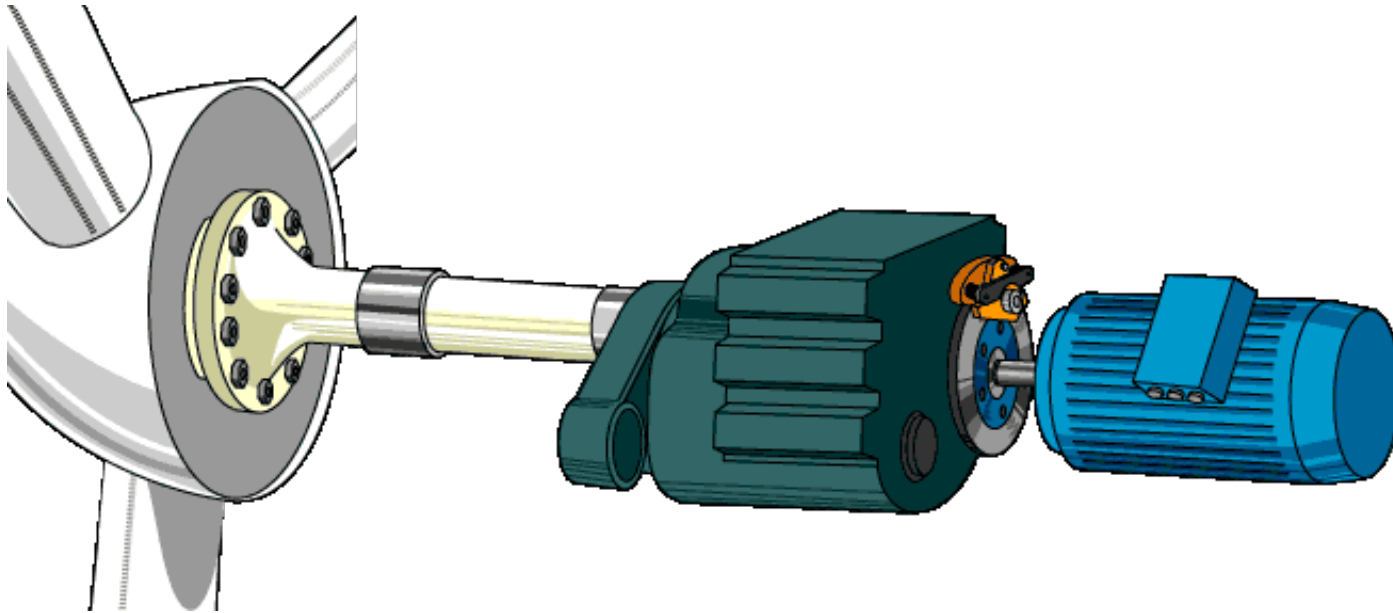

The *drivetrain* consists of a *gearbox* connected to the rotor by a *low-speed shaft*; the gearbox is needed to increase the speed of the rotor from typically 20-50 revolutions per minute to the 1000 rpm (6-pole) or 1500 rpm (4-pole) required for driving most types of electric generator .

# HAWT : the generator

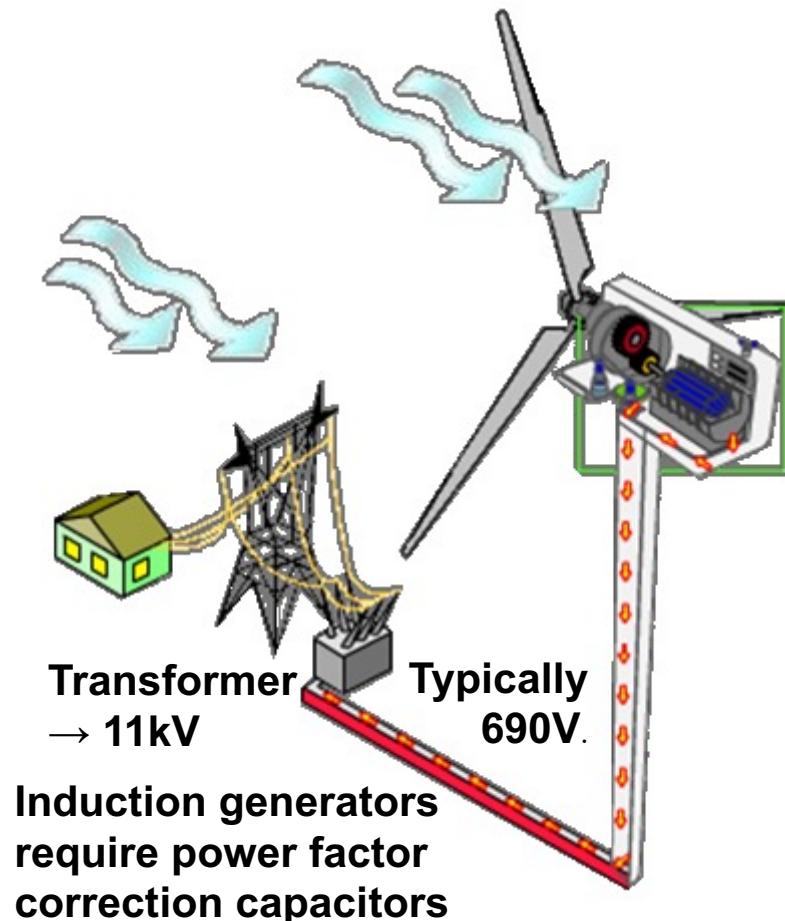

Grid-connected turbines drive a 3-phase alternating current generator to convert mechanical power to electrical power.

Generators are of two types: *synchronous* and *asynchronous*

Practically all generators used throughout the world to generate electricity from mechanical power are of the synchronous type (slightly more efficient) with the **exception of wind turbines**, which normally use **induction generators** (due to reactive power).

# HAWT : the mechanical brake

If the pitch set angle is substantially increased, the torque generated is accordingly reduced; this mechanism is used to initiate the shut down of a wind turbine in cases of emergency.



To bring the rotor to a complete stop, mechanical brakes are fitted to one drive train shaft; a brake on the high speed shaft is cheaper as the braking torque required is substantially less than if the action were taken on the low speed shaft. However high speed shaft brakes depend for their effectiveness on the integrity of the gearbox.

It is essential that the braking system is fail-safe in the event of loss of electrical power or other failure; therefore the braking system is designed so that the turbine is in the braked condition unless there is hydraulic pressure to deactivate the brake.



<http://www.youtube.com/watch?v=OeoVaqdwZXw&feature=related>



# HAWT : the yaw system



A horizontal axis wind turbine has a yaw system that turns the nacelle so that the wind direction is perpendicular to the swept rotor area; this is achieved by two motors engaging on a gear ring at the top of the tower.

To prevent nacelle backlash on the yaw gearing it is usual to fit brakes that are activated when the yaw system is inactive.

A wind vane mounted on top of the nacelle senses the average wind direction and the wind turbine controller then operates the yaw motors.

# HAWT : the tower

<http://www.youtube.com/watch?v=jVwn2ivxyxM&feature=related>

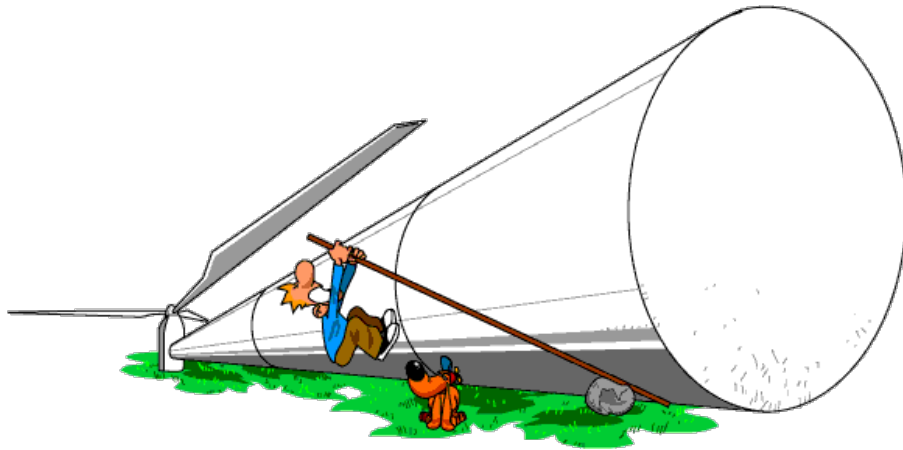

The tower of a wind turbine supports the nacelle assembly (weighing many tonnes), and elevates the rotor to a height at which the wind velocity is significantly greater and less turbulent than at ground level.

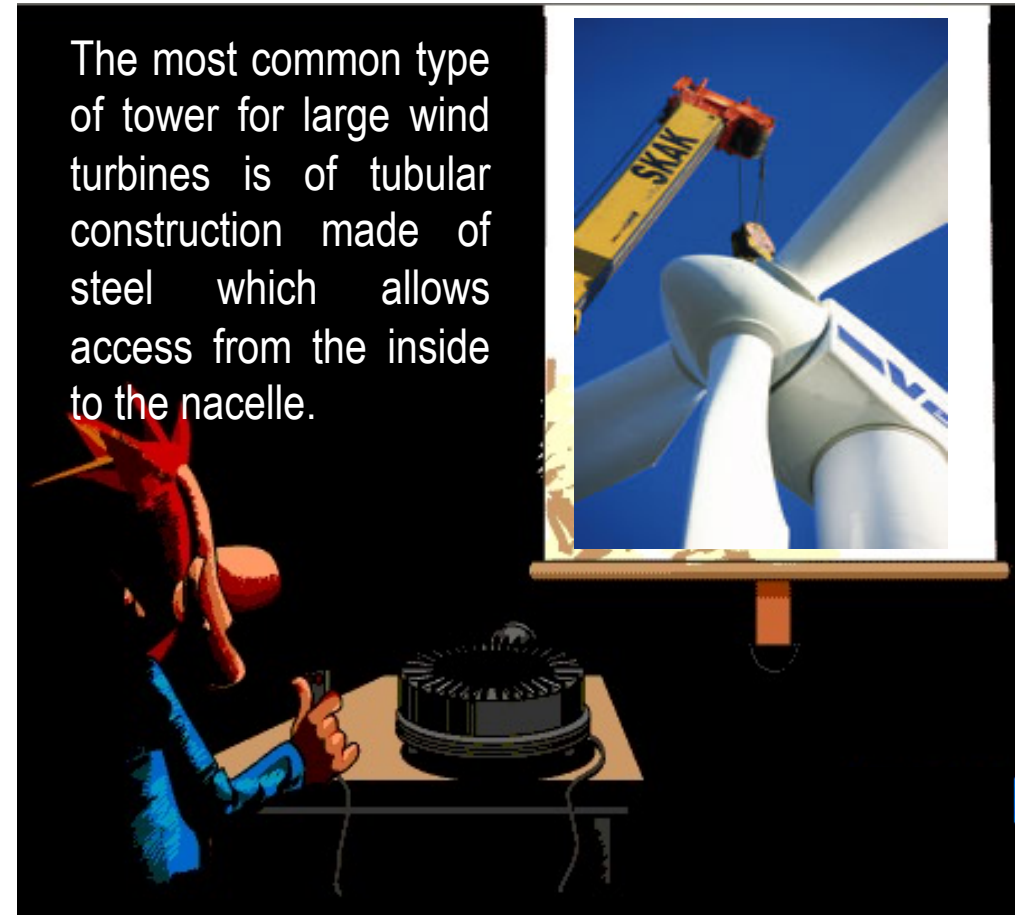

The most common type of tower for large wind turbines is of tubular construction made of steel which allows access from the inside to the nacelle.

# Wind turbines risks

- Machinery maintenance accidents
- Blade failures
- Falling ice
- Paragliders and small aircraft crashing into support structures
- Turbine's brake fails → the turbine can spin freely until it disintegrates
- Turbine blades may fall off due to manufacturing flaws
- Lightning strikes → rotor blade damage and fires



A turbine on fire after an oil leak

# Noise level and visual impact

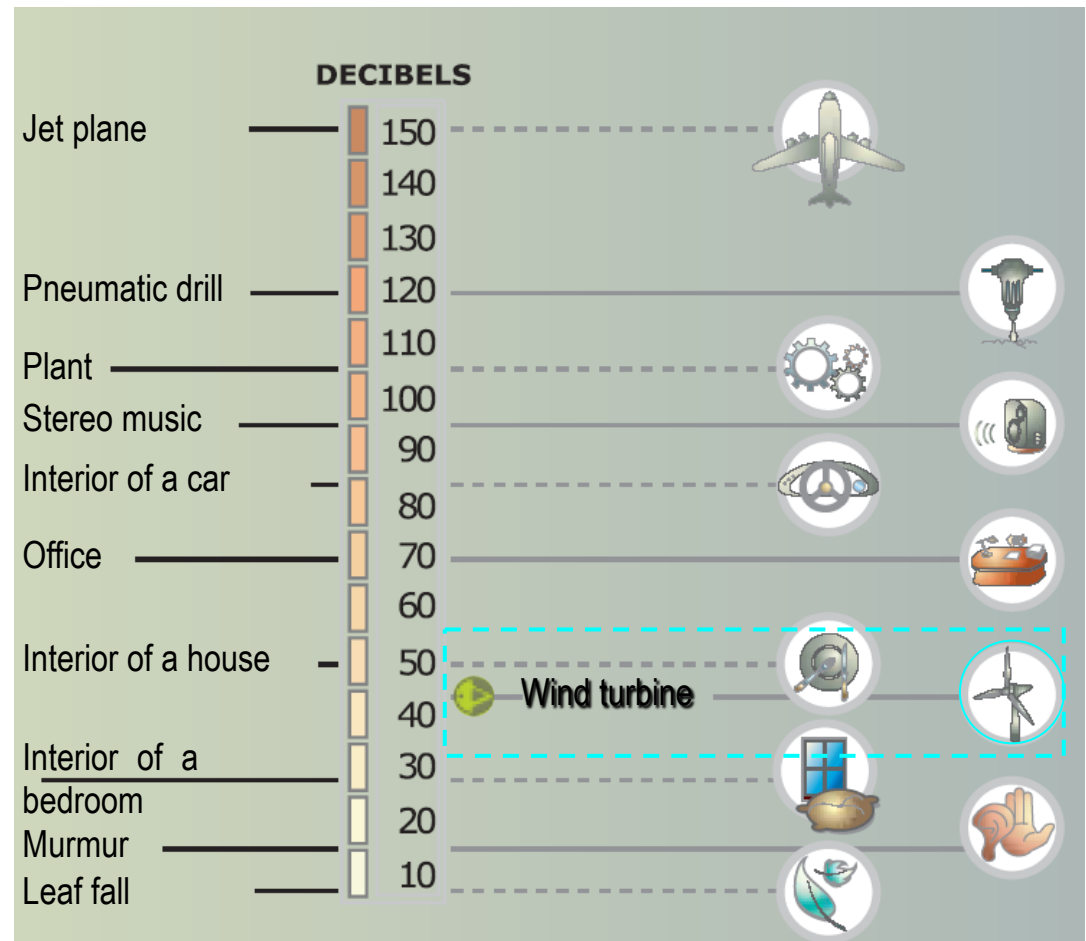
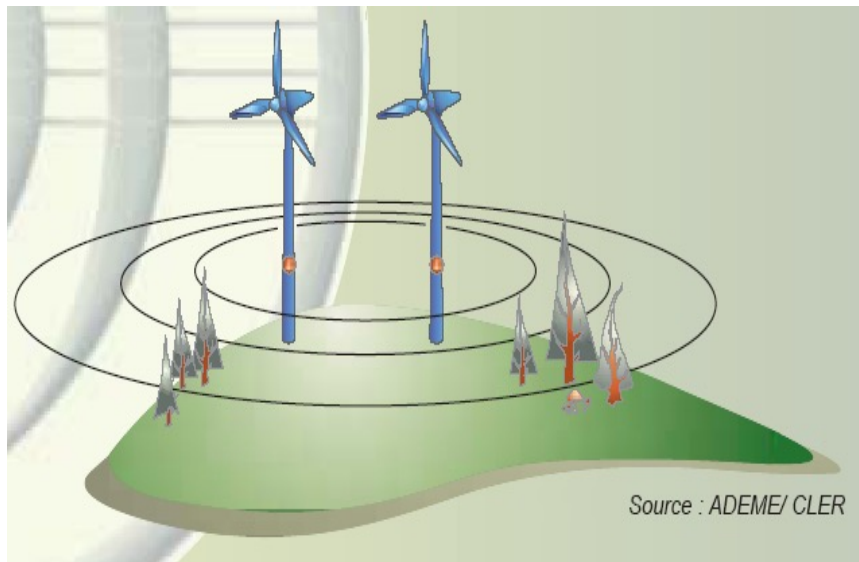

# Noise sources

## Electro-mechanical

- e.g. gears, vibration
- = distinct tones
- reduce by
  - ◆ special gears
  - ◆ acoustic insulation

## Aerodynamical

- airflow over blades
- = broadband ('humming')
- reduce by
  - ◆ blade cleaning
  - ◆ detailed blade design
  - ◆ lower  $\omega$  at low wind; night-time

- 45 dBA seems acceptable for most situations
- minimum residence distance  $\approx 350$  m, for a 300 kW turbine

# Wind **farm** features

- usually 10-30 turbines
- spacing: min. 5 D(iameters), up to 10 D; usually 7 to **8 D !**
- transformer at each tower base; 1 grid transformer for the whole site
- underground cables between the units
- Timing (ideally):
  - ◆ Siting and permissions 1 yr
  - ◆ Construction & commissioning 1 yr
  - ◆ Operation 20 yr
  - ◆ Decommissioning (or refurbishing) <0.5 yr

# Land use

- A rough estimate gives, for wind power implementation:

- **power density**  $\approx 3 \text{ MW}_{\text{el}} / \text{km}^2$

(remember that solar input  $\approx 1 \text{ kW}/\text{m}^2$ ; we estimated 2% of this to be converted to wind energy ( $20 \text{ W}/\text{m}^2$ ), and 35% of this to be available close to the Earth surface ( $7 \text{ W}/\text{m}^2$ ); with typical conversion efficiency of 40%, we arrive at  $\approx 3 \text{ W}/\text{m}^2 = 3 \text{ MW}/\text{km}^2$ )

- **energy density**  $\approx 7.5\text{-}10 \text{ GWh} / \text{km}^2$  ( $7.5\text{-}10 \text{ kWh}_{\text{el}} / \text{m}^2$ )

(i.e. for 2500-3300 operating hours per yr, i.e. 30% to 40% load)

(compare that with a PV array of 15% efficiency, you obtain  $> 100 \text{ kWh}_{\text{el}} / \text{m}^2$ , yet the material use is much lower for WT - compare the blade area to the whole PV array!)

- The effective **land-use** occupied by the machinery, however, is **only ca. 1%**.

- The remaining 99% can be typically of agricultural use.

# HAWT wind farm in California

Altamont wind farm: 6,800 small turbines with a capacity of 700 MW.

Annual generation of  $>1$  TWh of electricity



Area occupied: ca  $150 \text{ km}^2$   
(i.e.  $7 \text{ GWh}_{el}/\text{km}^2$ )

Electrical losses in a wind farm are 3-5% of the annual electrical output.

# HAWT Horns Rev wind farm (DK)

One of the largest offshore wind farms (160 MW total; 80 turbines) at the Danish west coast, sited 14-20 km into the North Sea.

Maximum tip speed can be higher (**120 m/s**) than with on-shore WT (**70 m/s**), since there is no noise limitation; hence rotors can be of lower solidity.



The Danish Government's plans to install wind turbines with a total capacity of 4 GW in Danish waters before 2030. Denmark already generates 48% of its electricity from wind.

# Wind farm costing

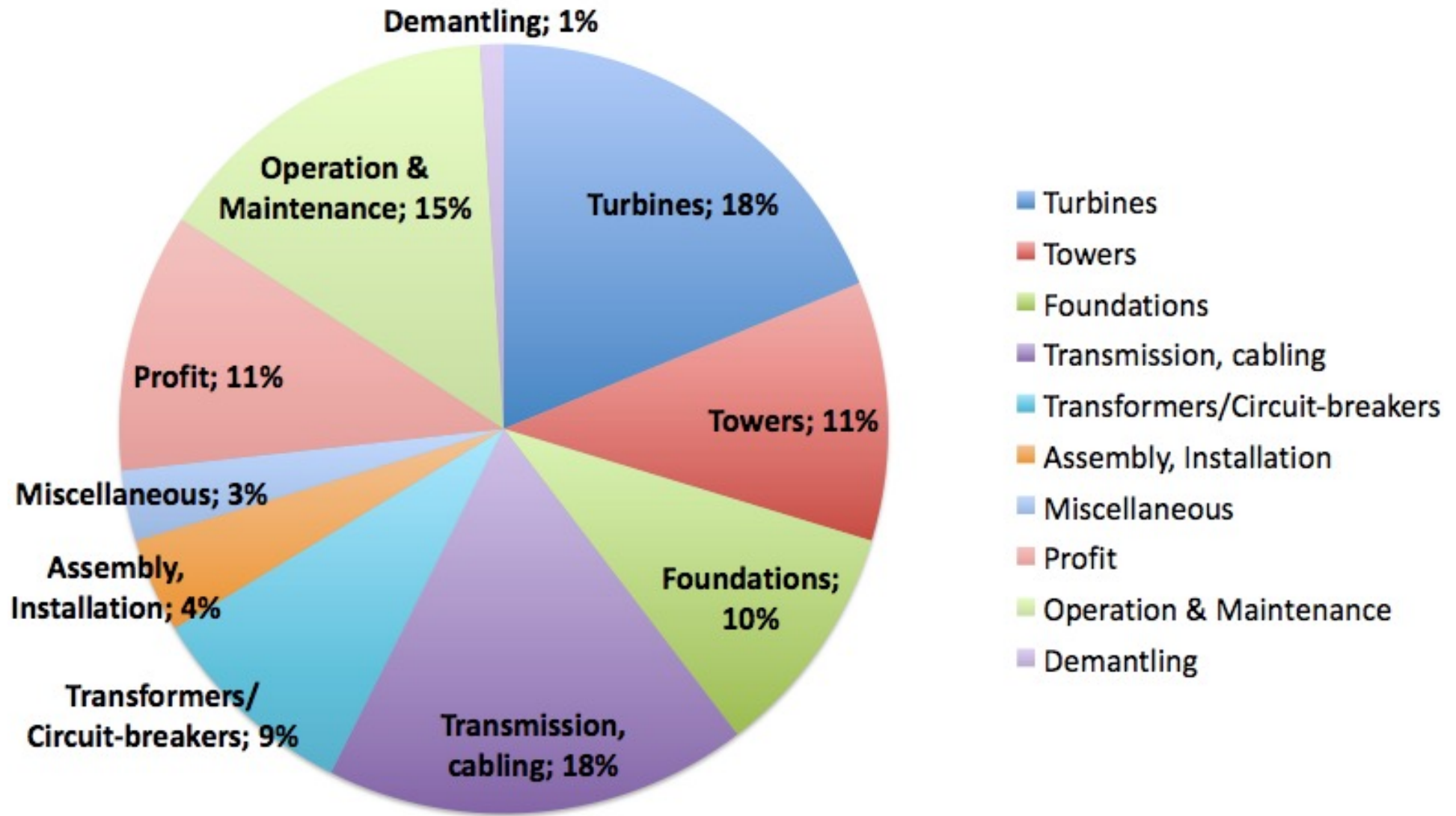

# VAWT general designs

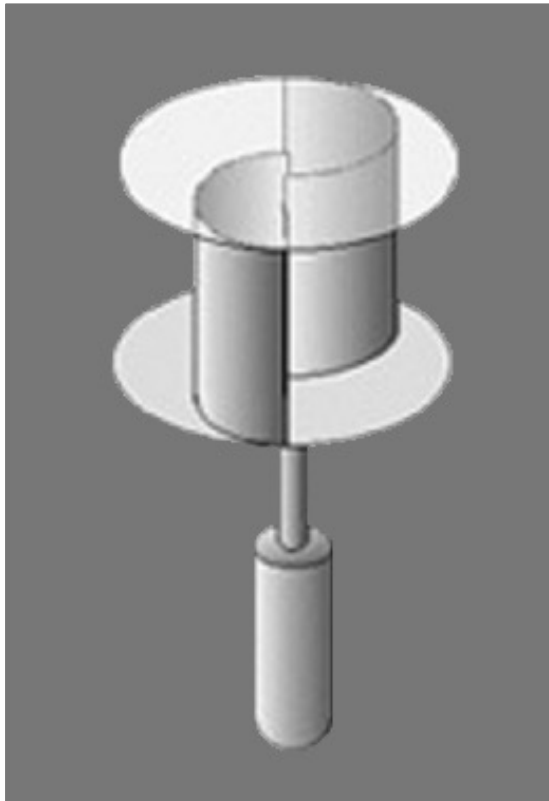

**Savonius Rotor**

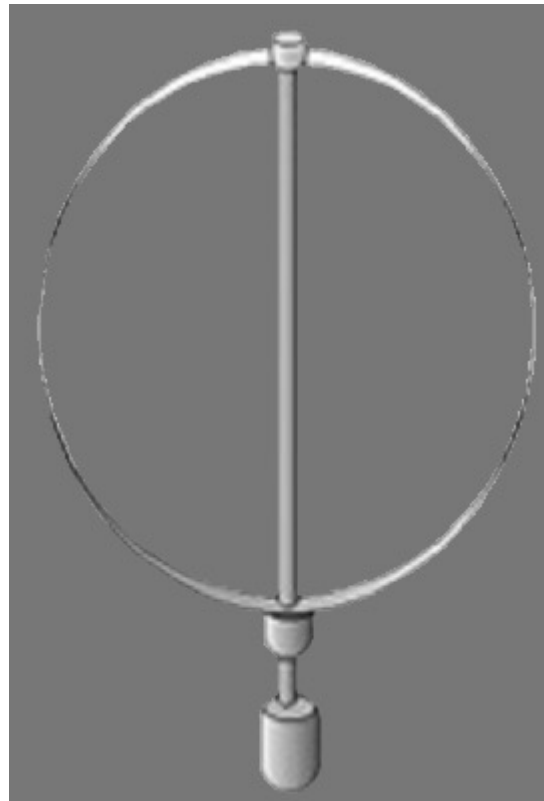

**Darrieus Rotor**

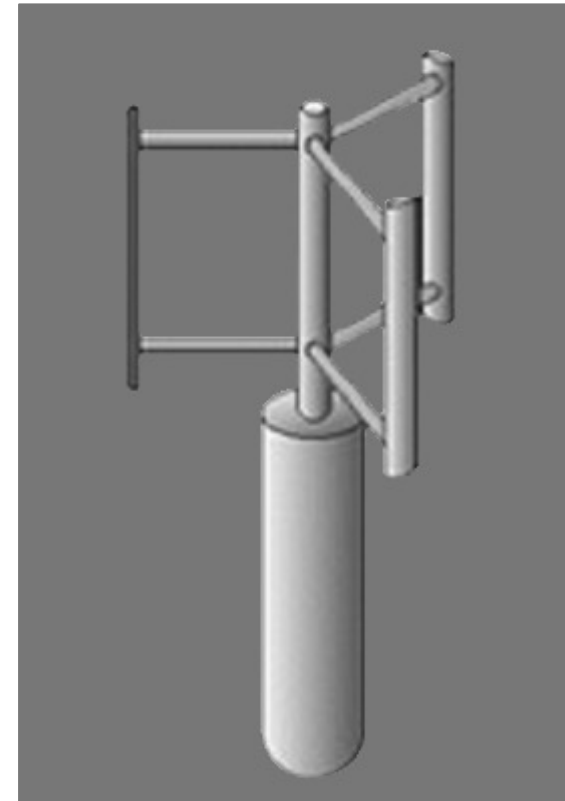

**"H" Rotor**

# VAWT : Savonius rotor

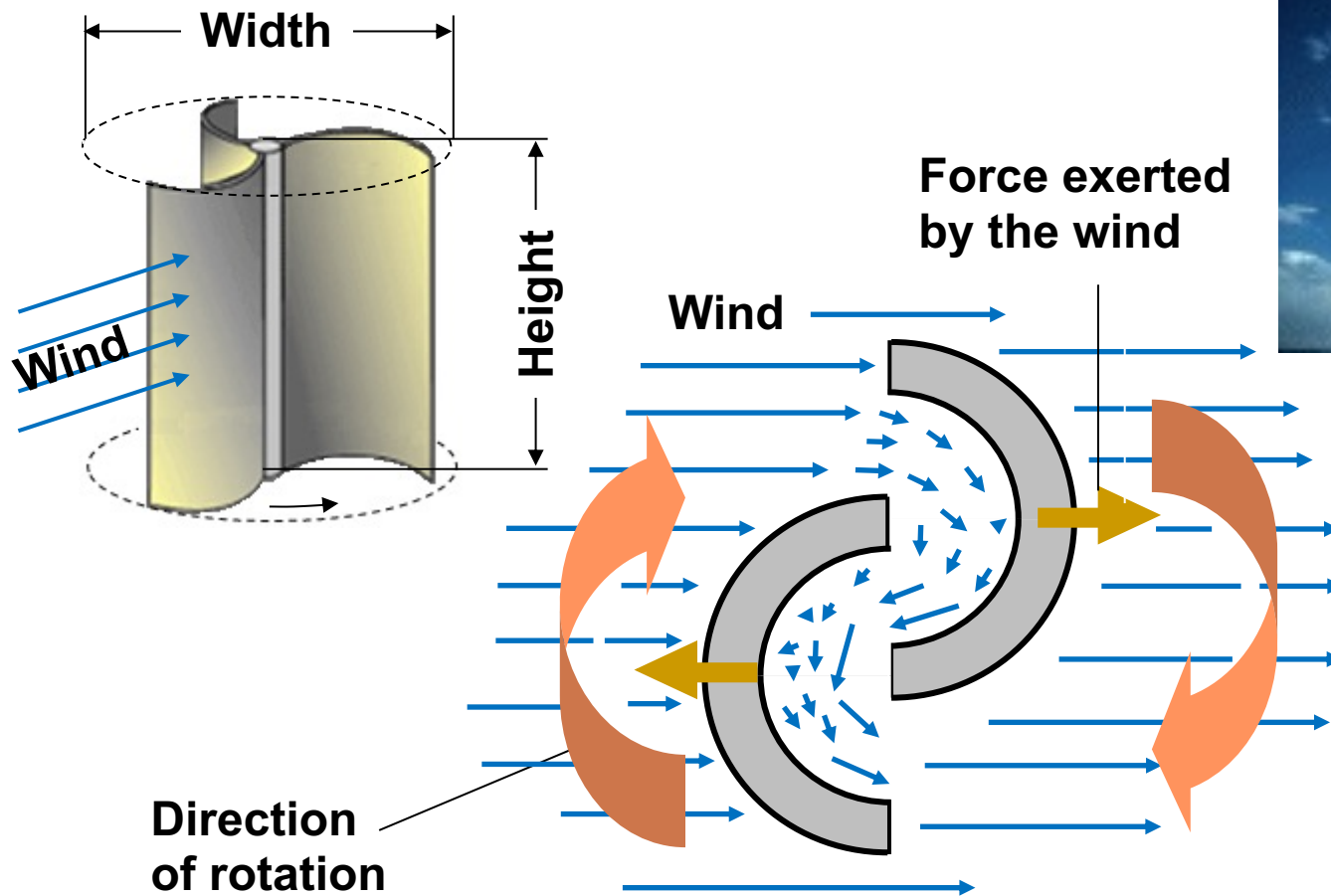

The Savonius Rotor is actuated by the **drag** forces

# VAWT: Darrieus Rotor

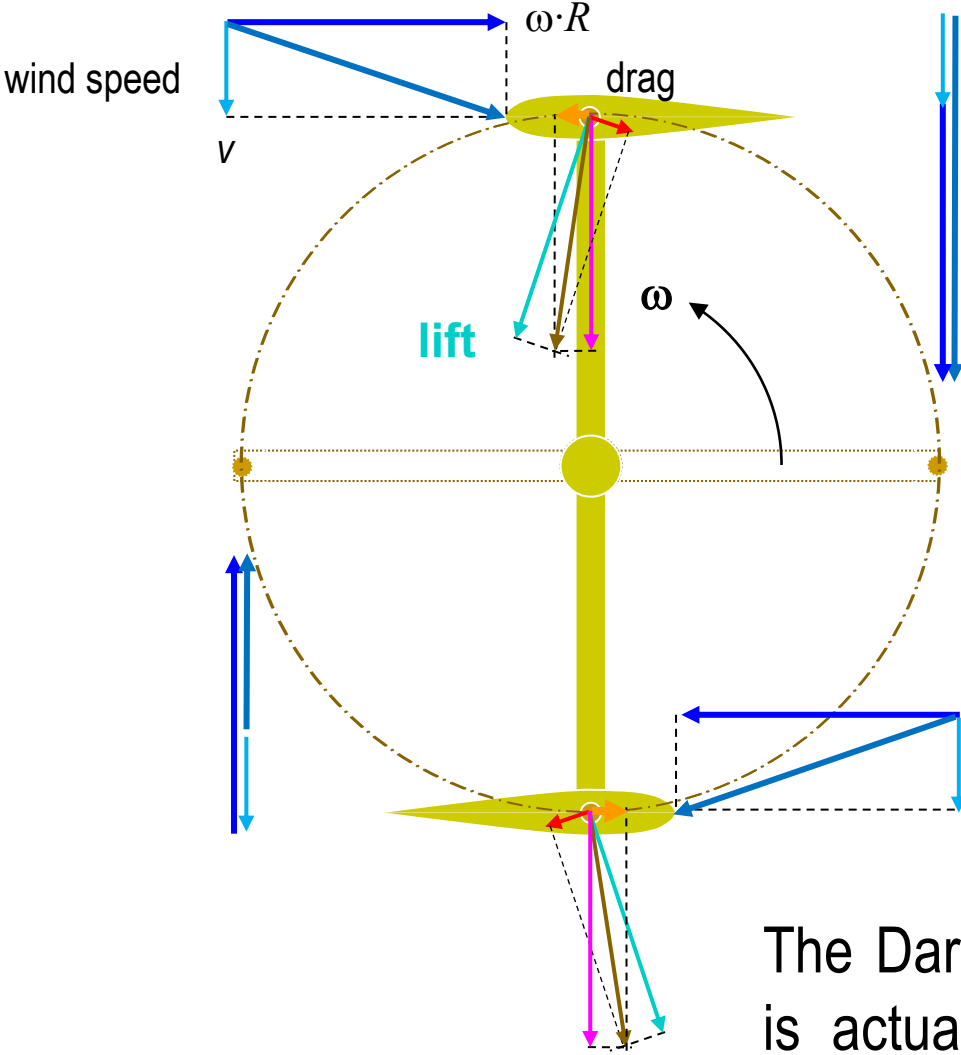
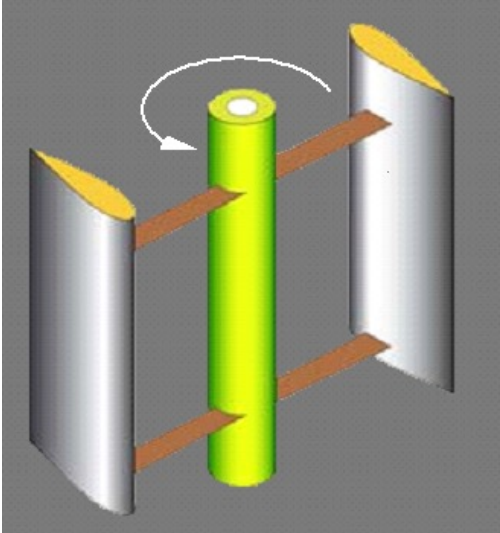

The Darrieus Rotor is actuated by the **lift** forces