

Renewable Energy

Prof. Sophia Haussener

MER Jan van Herle

Laboratory of Renewable Energy Sciences and Engineering

Administration

- Course:
 - Tuesday: 2h lecture (10:15-12:00), CM15
 - Responsible: Prof. Haussener, ME D0 2926,
MER van Herle, ME , A2 392
- Exercise:
 - Tuesday, 1h exercises (12:15-13:00), ELD 020 & ELE 111
 - Responsible part Haussener: Sha Li, ME D0 2726
- Remarks:
 - Expected contributions from your side:
4 credits \approx 4x30 hours = 120 hours
14x3 hours lecture/exercise \rightarrow 120-42 = 78 hours at home/library
= 5.5 hours/week at home/library

Administration

- Exam: written at the end of the semester
closed books, only calculator and 10 A4 pages (single sided, or 5 pages double sided) personal summary can be used
- Course notes and exercises are online before the lecture (moodle.epfl.ch)
Please print them individually if you need a printout
- References (complementary):
 - David McKay, Sustainable Energy – without the hot air, UIT Cambridge (available on web)
 - Kreith and Goswami, editors, Handbook of energy efficiency and renewable energy, Taylor and Francis Group, 2007.

Course structure

Outline

1. Introduction to energy economy
2. Revisiting power cycles
3. Wind
4. Geothermal
5. Biomass:
 - Biofuels
 - Biomass to electricity
6. Solar:
 - Solar thermal
 - Solar electricity
 - Solar fuels
7. Hydrogen
8. Electrochemical & thermo-electrical conversion
9. Storage
10. Hydro, ocean, tidal, wave

Course structure

	Lecture Wednesday (10:15-12:00)	Lecturer	Exercise Tuesday (12:15-13:00)
Week 1 (20.2)	Introduction	SH	Exercise 1
Week 2 (27.2)	Power cycles, ORC, co-generation	SH	Exercise 2
Week 3 (5.3)	Wind	JVh	Exercise 3
Week 4 (12.3)	Wind	JVh	Exercise 4
Week 5 (19.3)	Geothermal	SH	Exercise 5
Week 6 (26.3)	Biomass	JVh	Exercise 6
Week 7 (9.4)	Biomass	JVh	Exercise 7
Week 8 (16.4)	Solar thermal	SH	Exercise 8
Week 9 (23.4)	Solar electricity	SH	Exercise 9
Week 10 (30.4)	Solar fuels	SH	Exercise 10
Week 11 (7.5)	Hydrogen	JVh	Exercise 11
Week 12 (14.5)	Electrochemical and thermo- electrical conversion	JVh	Exercise 12
Week 13 (21.5)	Storage	SH	Exercise 13
Week 14 (28.5)	Ocean, tidal and wave	JVh	Exercise 14

What you will learn in this course:

- What is renewable energy?
- What are its current/future contribution to energy supply?
- For the different renewable energy sources:
 - the potential: theoretical vs. realistic
 - the essential physics and chemistry for conversion and storage
 - approaches to «harness» them
 - status of the technologies
 - the most useful applications and complementarities
- Renewable power plants you will know:
B-IGCC, PV, CSP, PEC, EGS, (μ)CHP, ...

Order of magnitude understanding

How much solar energy falls on 1 m^2 in 1 s on a nice sunny day at noon ?

- 1 J
- 10 J
- 100 J
- 1000 J

... and in winter, during any day, at any latitude?

Order of magnitude understanding

How much power can a water turbine develop from water flowing at $1 \text{ m}^3/\text{s}$ and falling from 100 m high ?

- 10 kW
- 100 kW
- 1 MW
- 10 MW

... and how big a wind turbine must be to develop the same power from a typical wind speed?

... (and what wind speed is ‘typical’?)

Order of magnitude understanding

How much power is contained in an ocean wave (per m width), 1 m high, and of wavelength 100 m ?

- 1 kW / m
- 3 kW / m
- 10 kW / m
- 30 kW / m

... and its difference to tidal power?

Order of magnitude understanding

How deep do we have to drill the earth soil to find it hot at 300°C ?

300 m

1 km

3 km

10 km

... and then how can we convert this to electrical power ?

... and furthermore:

- is heat pumping from the soil renewable?
- are bioethanol and biodiesel going to replace petrol?
- what about the biomass-energy competition with food ?
- can we go 100% renewable?
- ‘there is 10’000 times more solar energy around than what all humans consume around the planet, no worries!’
- it’s just of matter of cost?
- But renewable energy is free fuel, isn’t it?
- ... or a matter of time, for fossil fuels to run out?
- ... or of progress in new technologies?
- ... or of political incentive and subsidies?

What you are expected to know at the end

- the real potential of the different renewable sources
- use mass, momentum, and energy balance to estimate orders of magnitude
- be able to easily grasp and switch between kWh, MJ, GW, Mtoe, TWh, ...
- the right orders of magnitude (energy and power)
- the technologies to harvest fossil and renewable energies
- explain and calculate the main emission sources of energy conversion processes
- their best service in the energy supply spectrum
- be able to solve the exercises

Common energy units

• 10^6	mega	M	MJ	MW	MWh
• 10^9	giga	G	GJ	GW	GWh
• 10^{12}	tera	T	TJ	TW	TWh
• 10^{15}	peta	P	PJ		
• 10^{18}	exa	E	EJ		

TWh terawatthour = 10^{12} Wh = 1000 GWh = 3.6 PJ (electricity)

GWh gigawatthour = 10^9 Wh = 3600 GJ (electricity)

Mtoe megatonne-oil-equivalent = 10^9 (kg) x 41.9 (MJ/kg) = 41.9 PJ

Examples of energy and power content

- Energy
 - Daily need of an adult : 6-8 MJ
 - 1 Liter of Oil : 36 MJ
 - 100 km in a VWGolf : 230 MJ (6.4l)
- Power
 - Computer : 100 -200 W (J/s)
 - Professional cyclist : 450 W
 - Adult : 100 W
 - 100 students : 15 kW
 - Car engine : 75 kW (~100 hp)

From resources to products

- **The energy used is not the energy that is harvested**
- **Energy resources (primary energy)**
 - Non renewable (from a reservoir)
 - Renewable (capturing the sun energy and incorporating into a system)
- **Energy services (final Energy)**
 - Temperature in a room
 - Data from internet
 - Mobility

Definitions

- **Primary energy consumption**
 - Energy contained in raw fuels before the start of the conversion chain.

- **Final (distributed) energy consumption**
 - Energy received by consumers and businesses, not including the energy losses in the conversion sector, and from distribution. This indicator evaluates the participation of each type of fuel (solid fuels, oil, gas, renewables)

Let's enumerate all energy sources we know...

BIOMASS

WIND

WASTES

COAL

GAS

HYDRO

SOLAR – DIRECT

TIDES

NUCLEAR

GEOHERMAL

OIL

SOLAR – P.V.

WAVES

SOLAR – THERMAL

...and see how we have been using these

Switzerland - Energy

Where do we stand today? Switzerland

Primary energy 1'013'200 TJ
Transformation
Final energy consumption 765'070 TJ

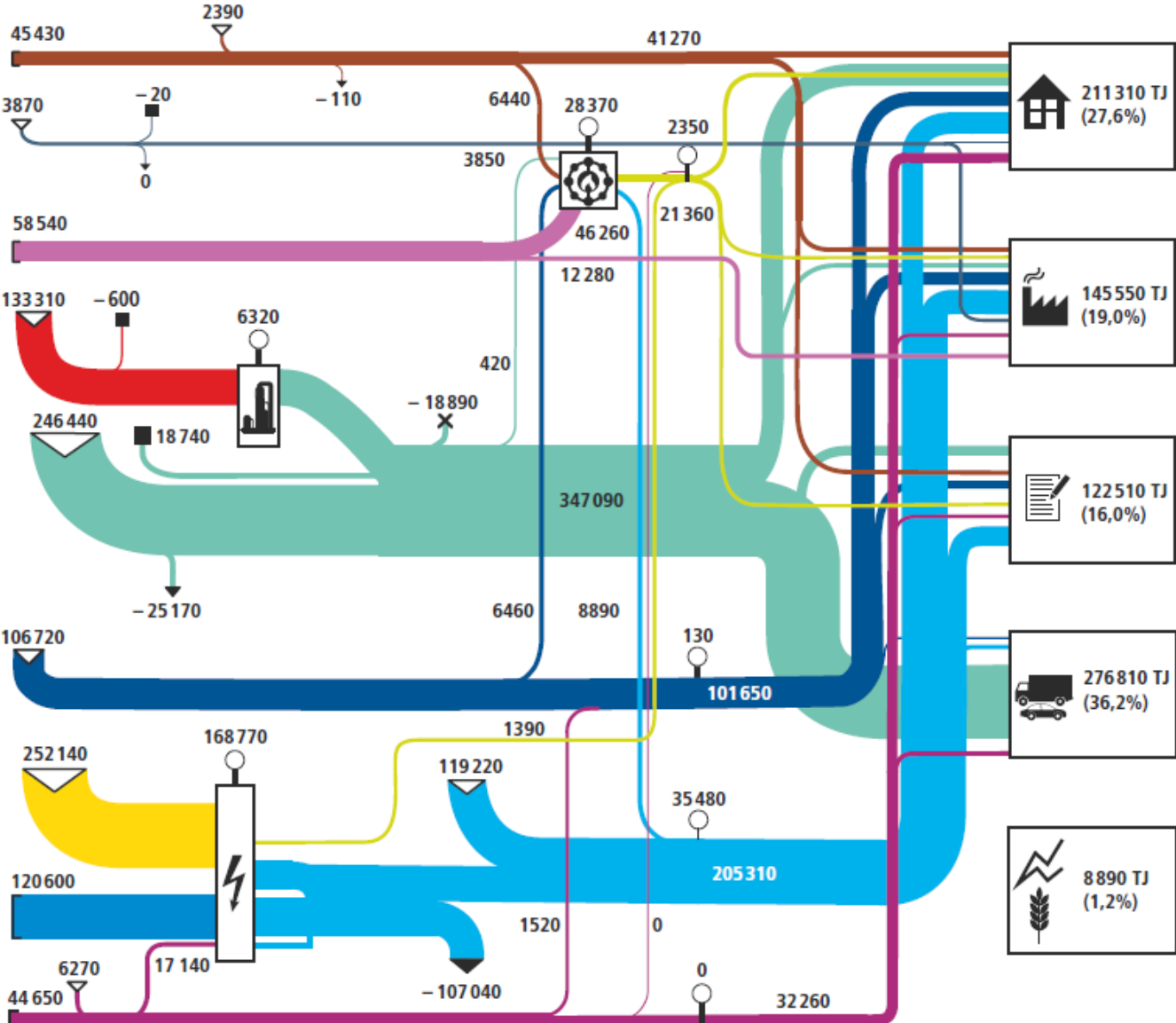

Primar Energy - CH 2022

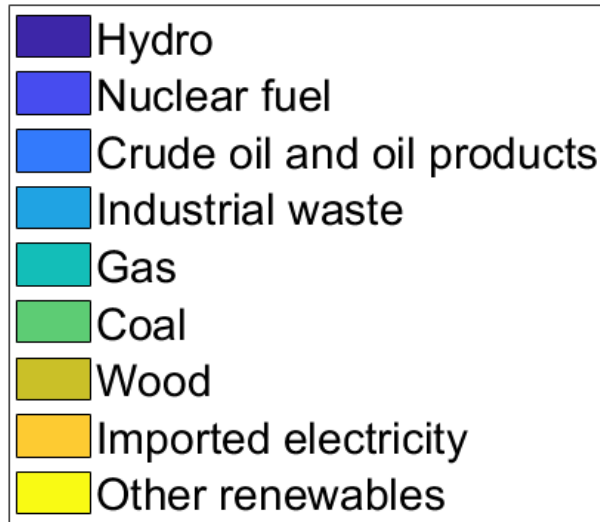

25%

36%

Total: 1'025'380 TJ

Other renewables: Solar, wind, biogas, biofuels, environmental heat

Final Energy - CH 2022

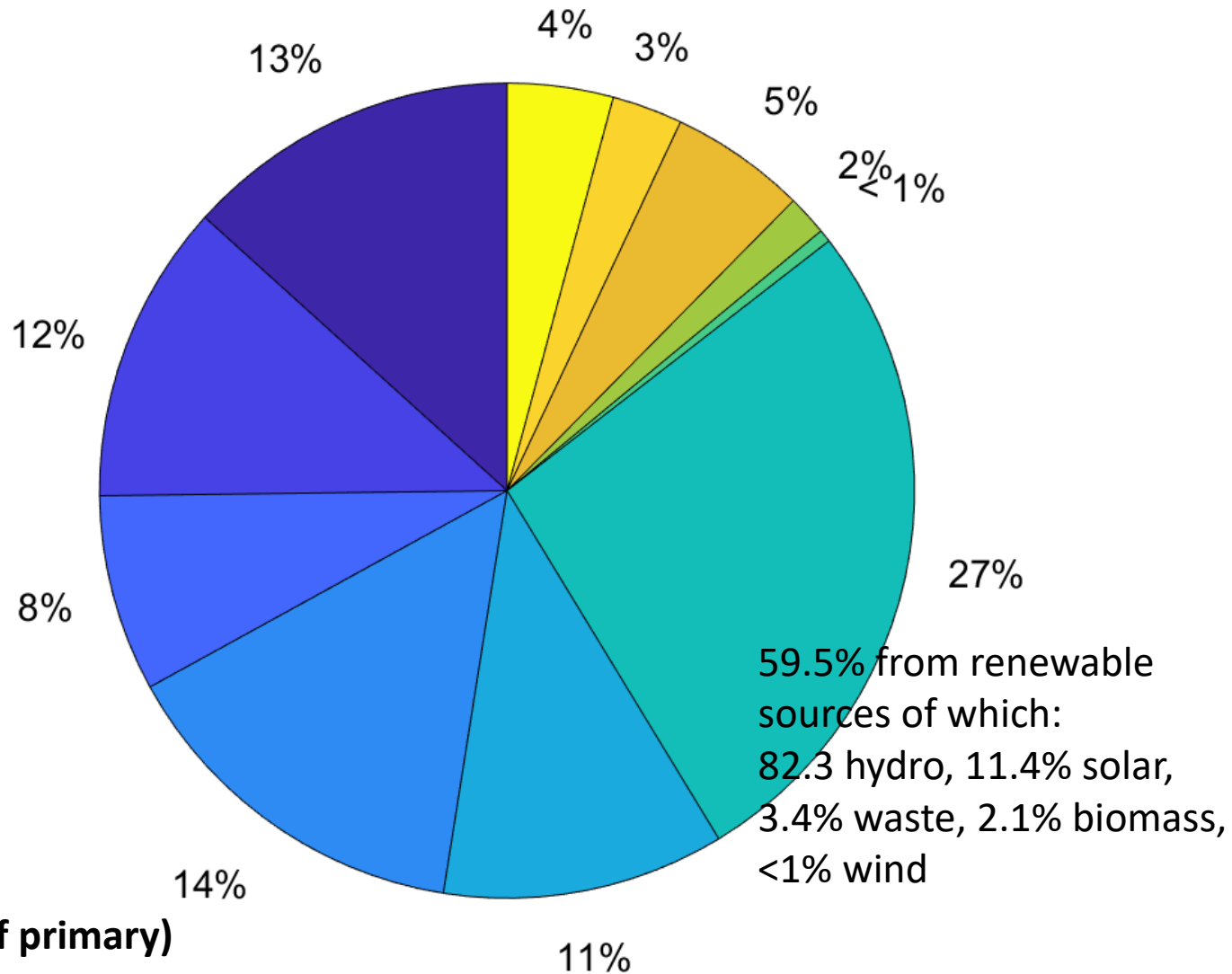

Other renewables (4.2%): Solar (0.3%), environmental heat (2.7%), biofuels (0.9%), biogas (0.2%)

End-use shares by application

6.3% of electricity used in transport
(mostly railway: 89%)

MOBILITY

ELECTRICAL DRIVES

Transportation
fuels
36%

Electricity
27%

Heating
fuels
37%

HEAT

Part of electricity (ca. 30%) used in heating:
9 PJ for heat pumps
and ~ 53 PJ for direct electric heating
(2/3 process heat and 1/3 space heat)

End-use by application: detail

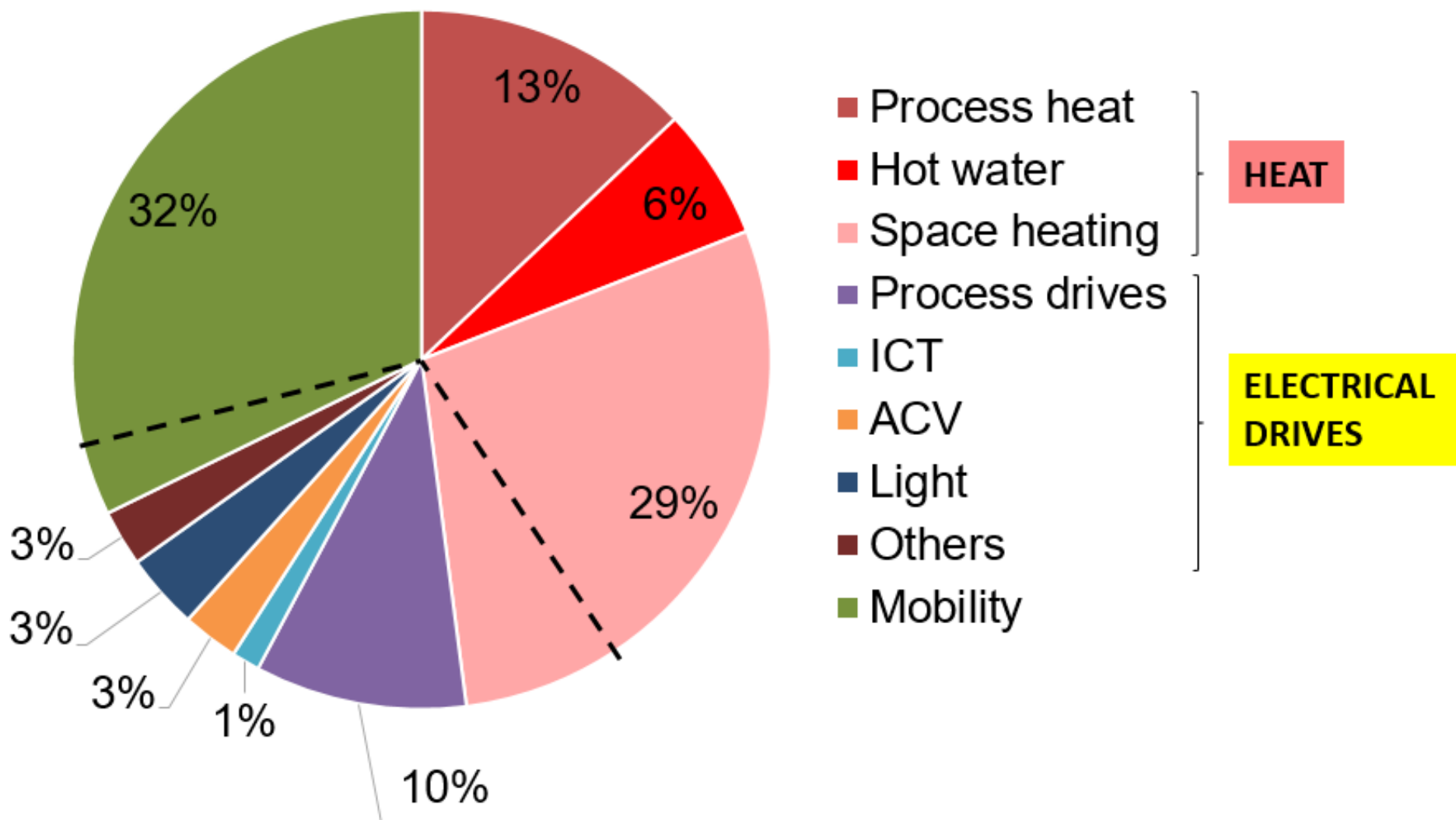

Final energy use ...

- There are 5 energy end services:
 - Space heat 20°C
 - Sanitary hot water 40°C
 - Process heat $>40^{\circ}\text{C}$
 - Electricity
 - Mobility

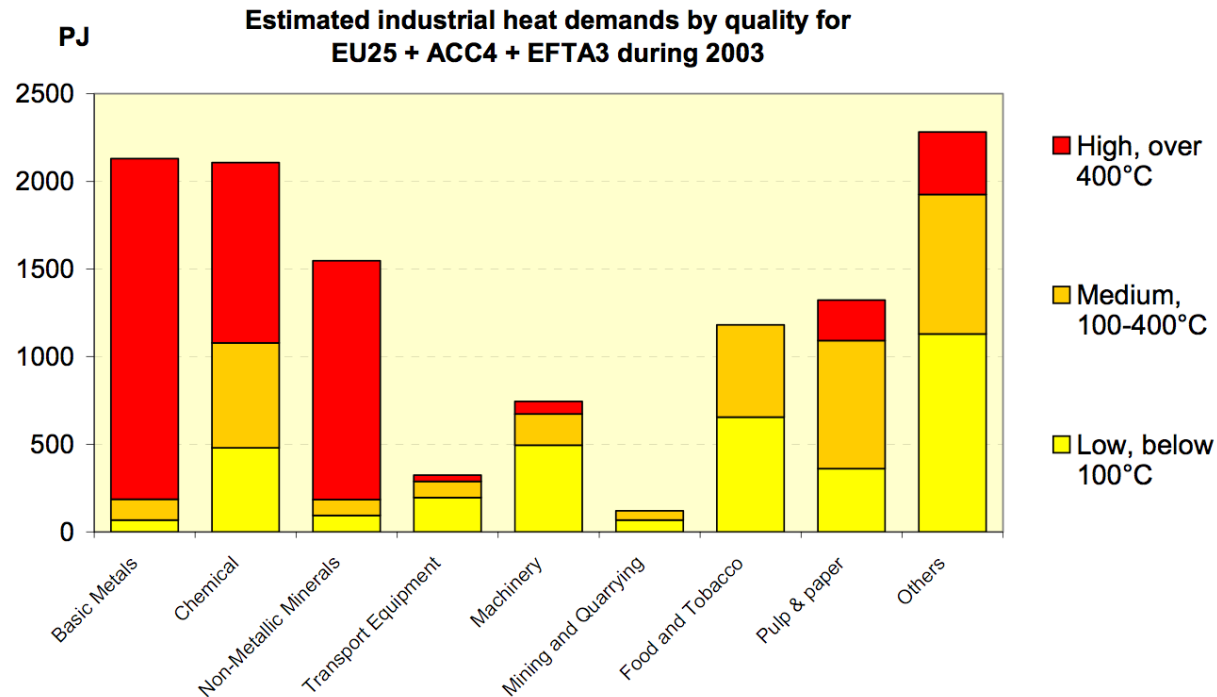

... and primary energy supply

- Key is to supply these end services in the most meaningful ways, considering:
 - Temperature level
 - Thermodynamics
 - Conversion technology
 - Scale of service / technology
 - **Efficiency**
 - **Savings**
 - Emissions, pollution, impact,...

Temporal evolution of final energy use

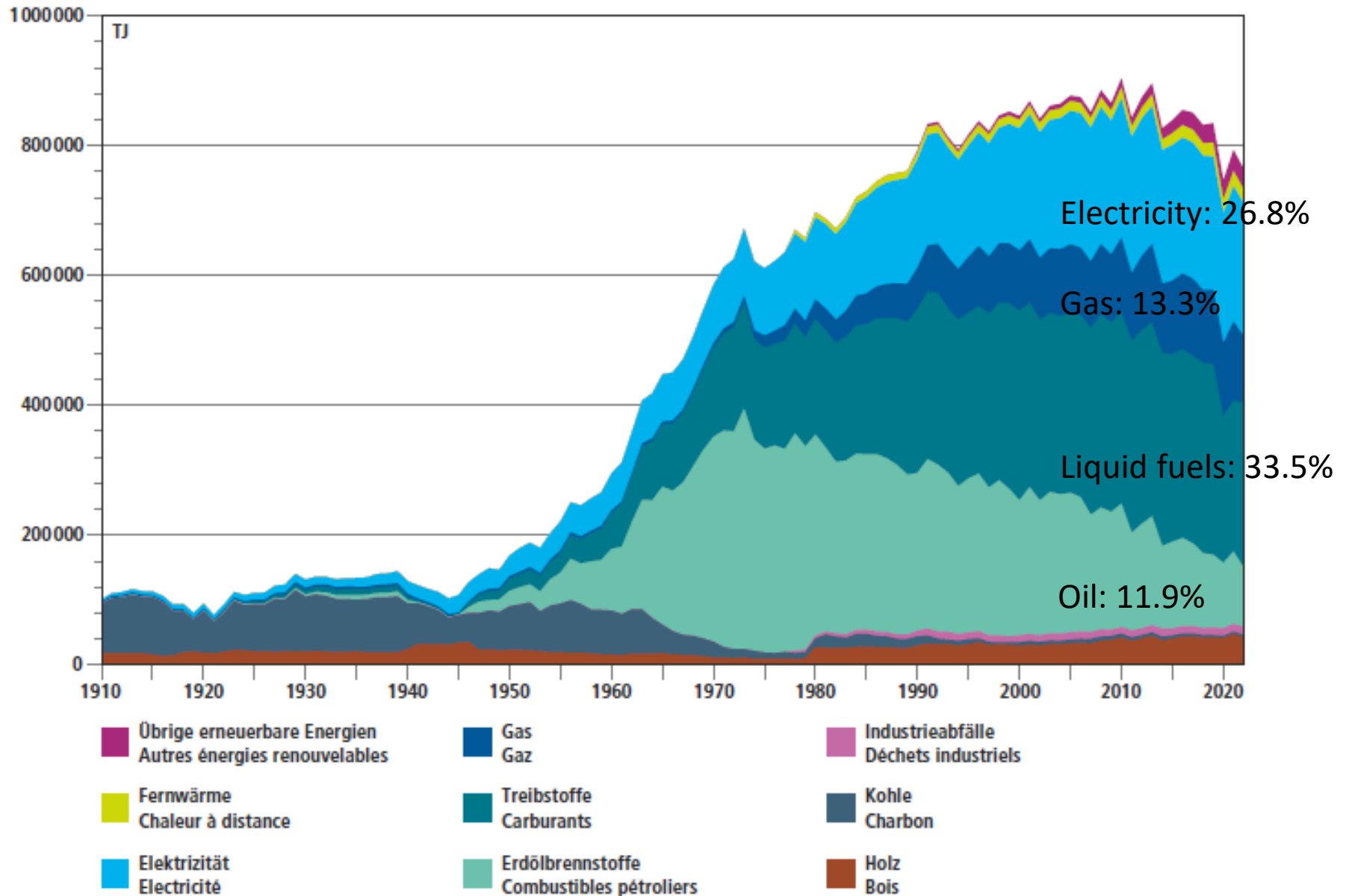

The link with the PIB

Fig. 15 Zusammenhang zwischen Energieverbrauch und wirtschaftlicher Entwicklung (1950–2022)
Relation entre la consommation finale et l'évolution économique (1950–2022)

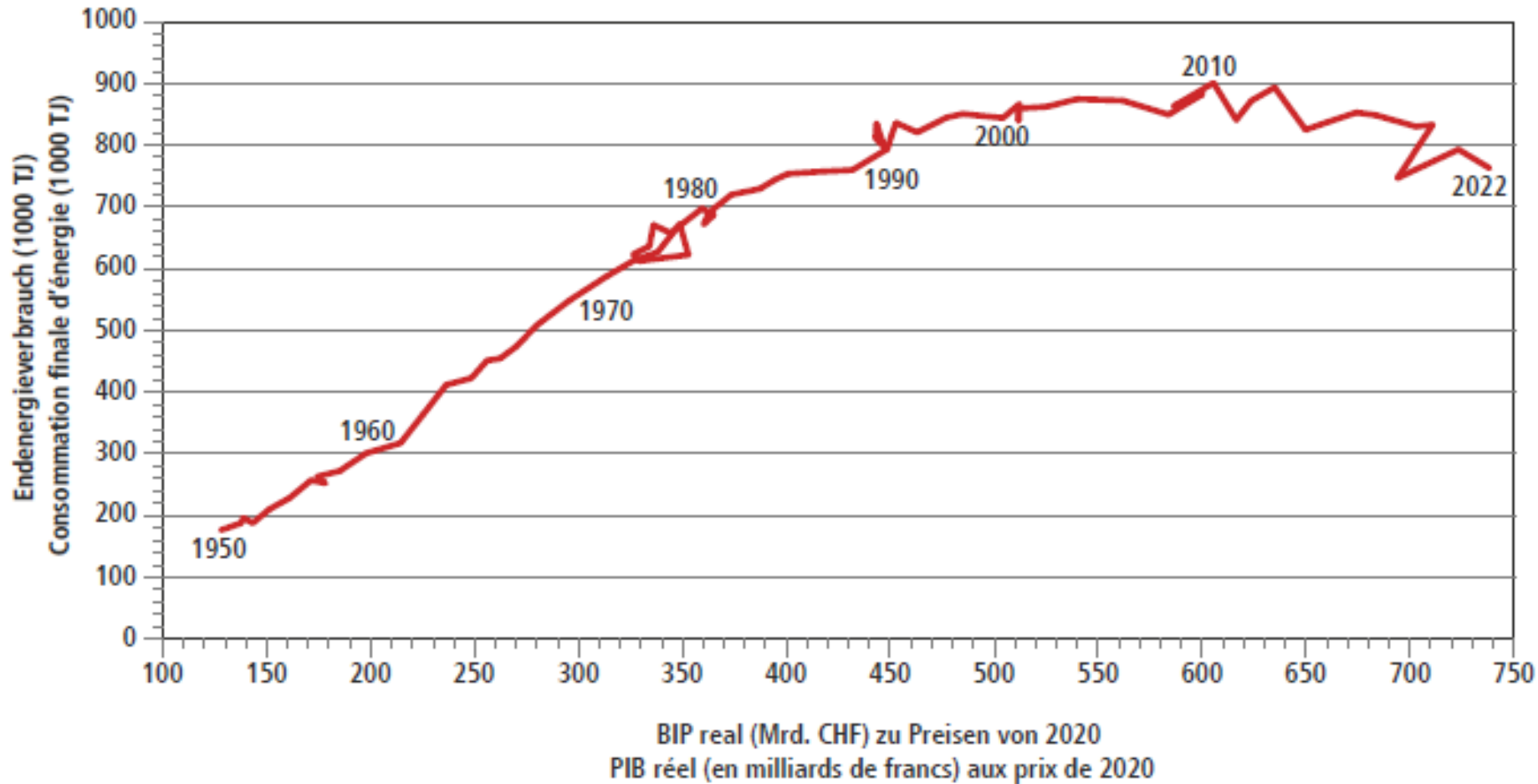

BFE, Schweizerische Gesamtenergiestatistik 2022 (Fig. 15)
OFEN, Statistique globale suisse de l'énergie 2022 (fig. 15)

Switzerland - Electricity

Temporal evolution of electricity production

Fig. 9 Entwicklung der einzelnen Erzeugerkategorien seit 1950
Evolution des différentes catégories de production depuis 1950

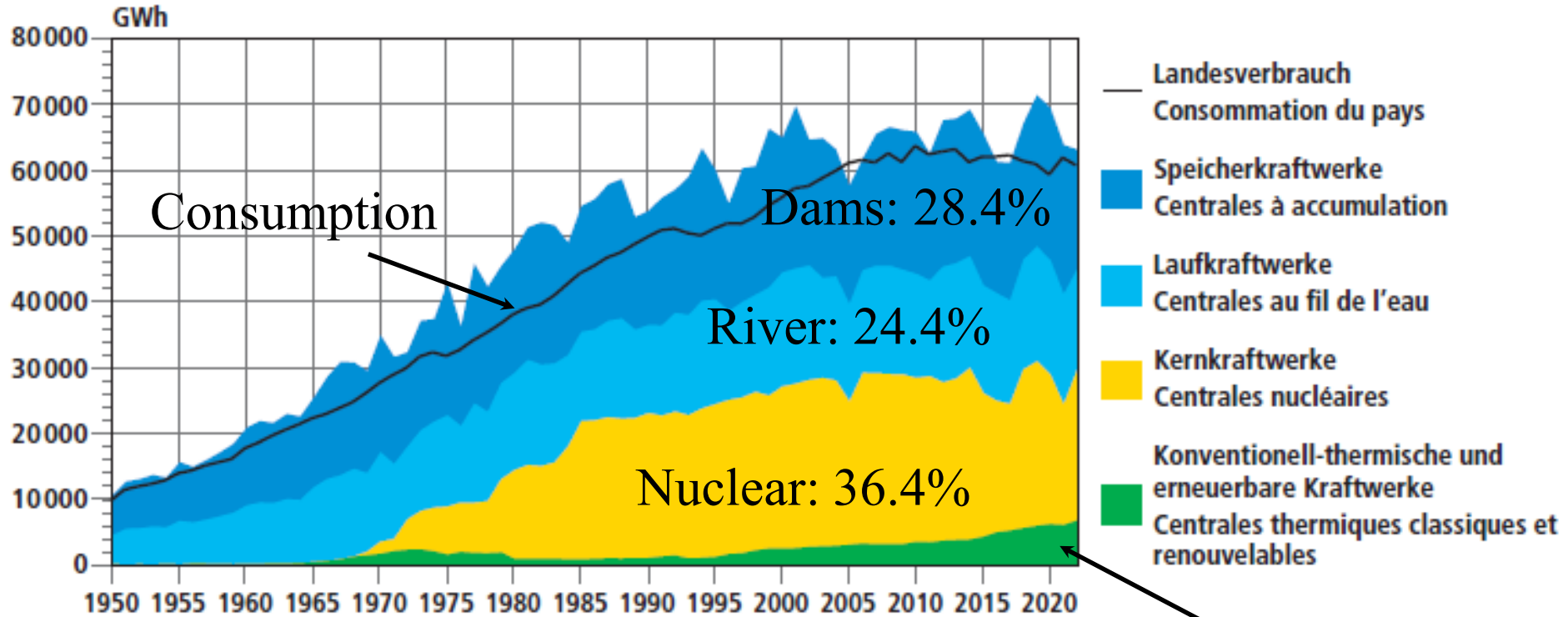

BFE, Schweizerische Elektrizitätsstatistik 2022 (Fig. 9)
OFEN, Statistique suisse de l'électricité 2022 (fig. 9)

Conventional thermal and
new renewables: 10.8%

Electricity balance: Production vs Consumption

Fig. 10 Monatliche Erzeugungsanteile und Landesverbrauch im Kalenderjahr 2022
Quotes-parts mensuelles et consommation du pays durant l'année civile 2022

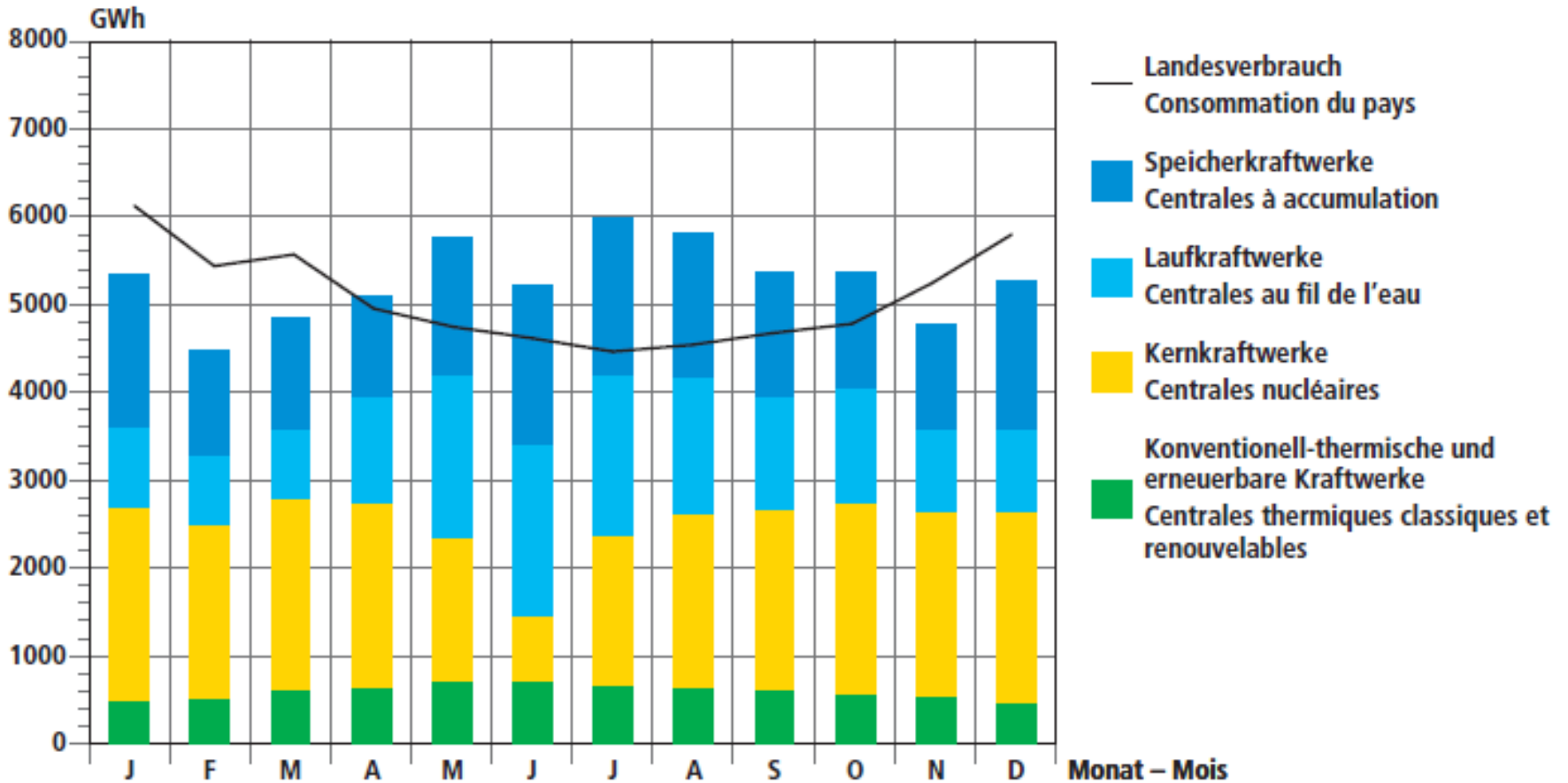

BFE, Schweizerische Elektrizitätsstatistik 2022 (Fig. 10)
OFEN, Statistique suisse de l'électricité 2022 (fig. 10)

Electricity production in Europe

Fig. 5 Produktionsstruktur einiger Länder 2021
Structure de production de divers pays 2021

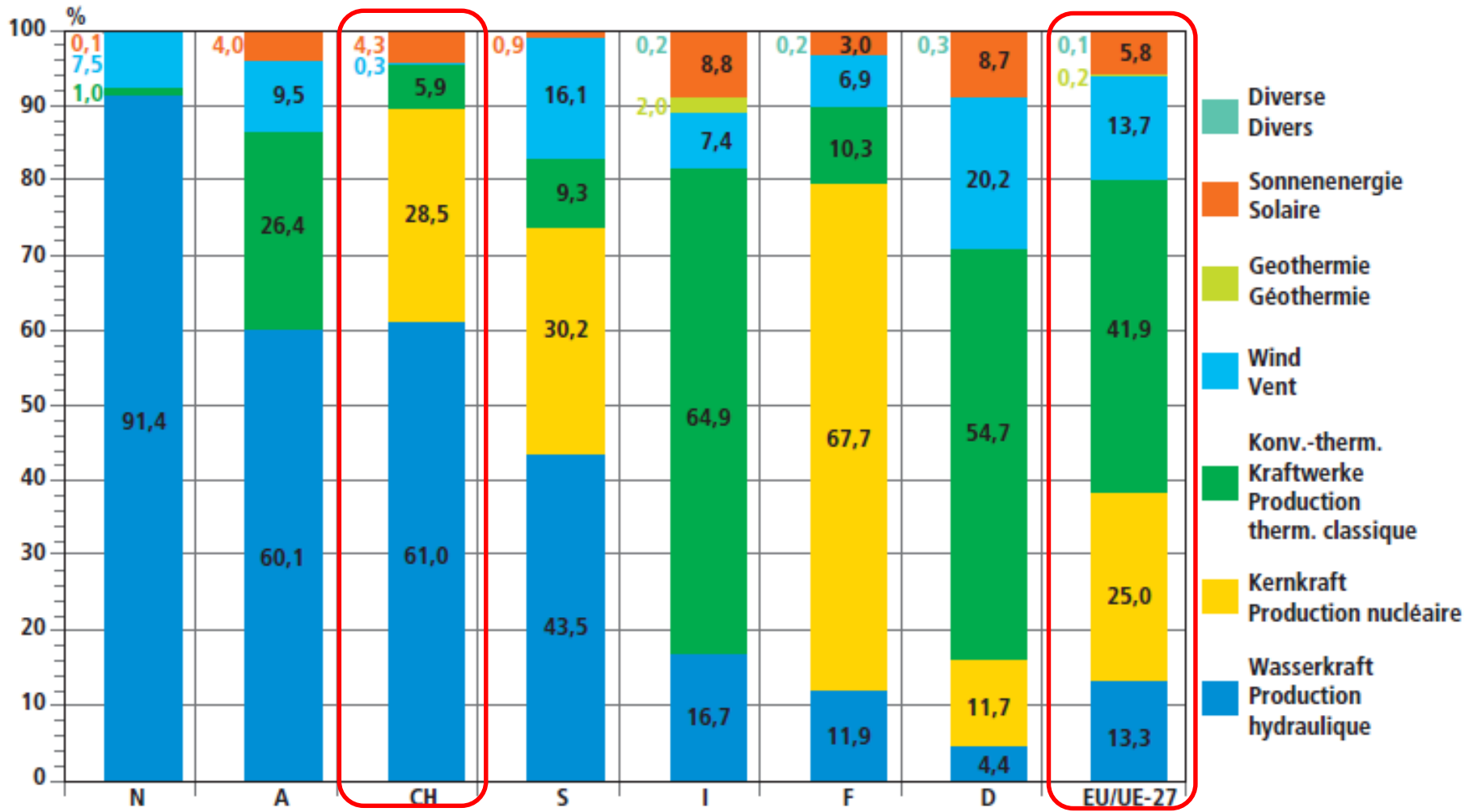

BFE, Schweizerische Elektrizitätsstatistik 2022 (Fig. 5)
OFEN, Statistique suisse de l'électricité 2022 (fig. 5)

Energy in Switzerland

The Swiss Energy ...

www.bfe.admin.ch

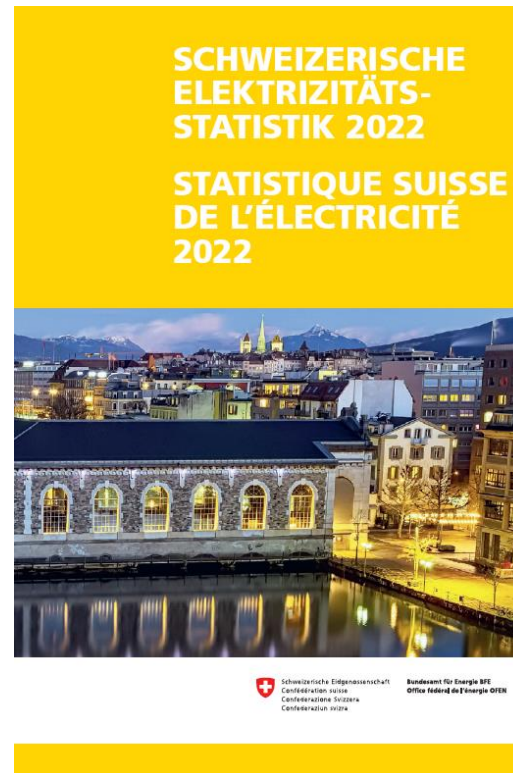
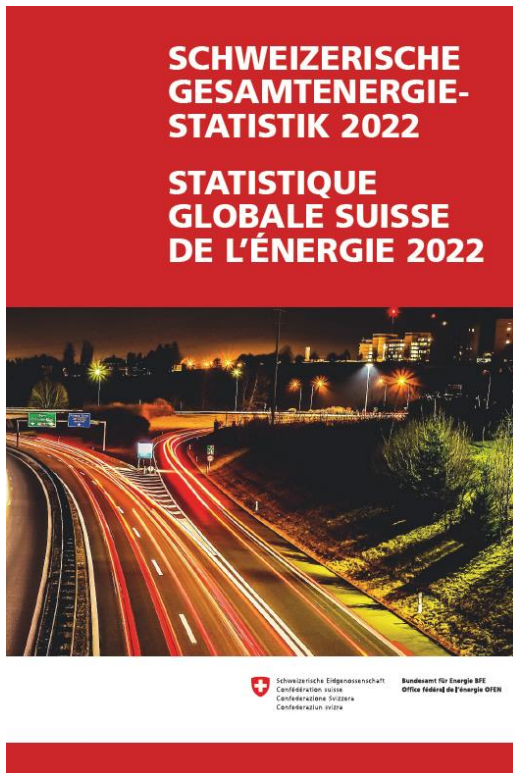

Global - Energy

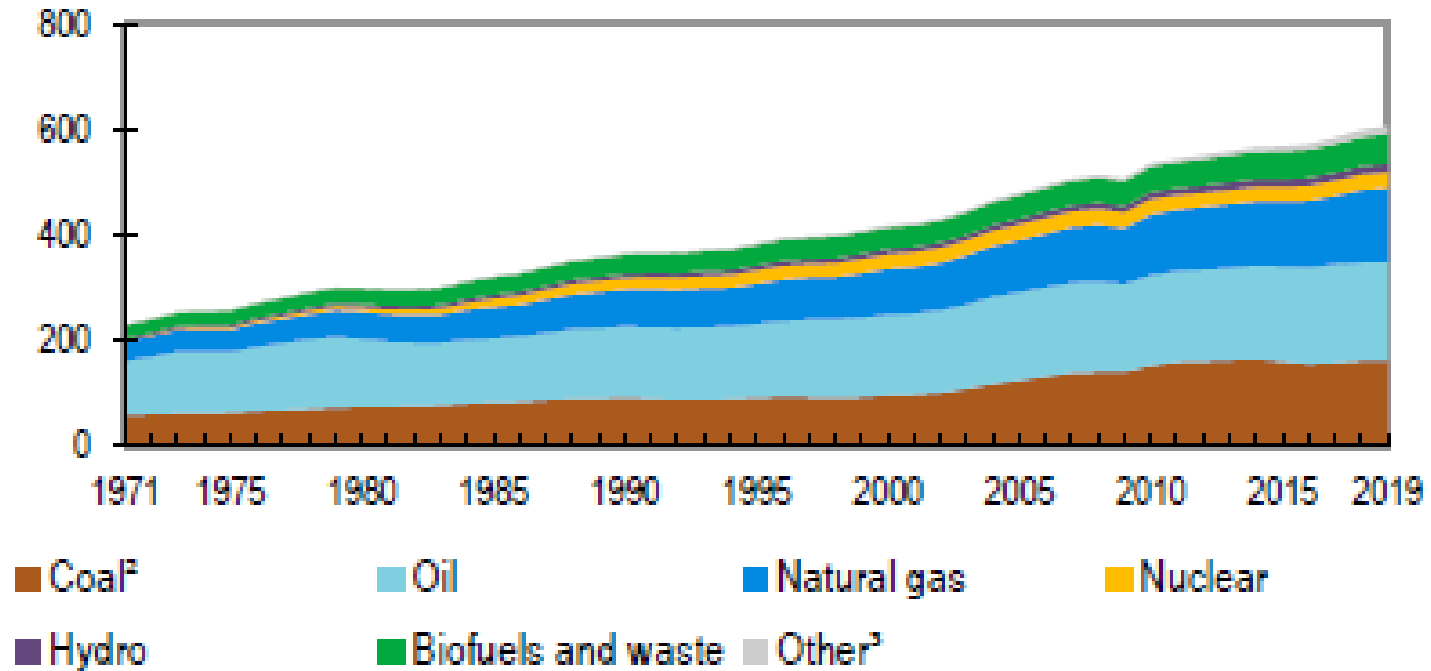

2019: 606 EJ
86% Non-renewable

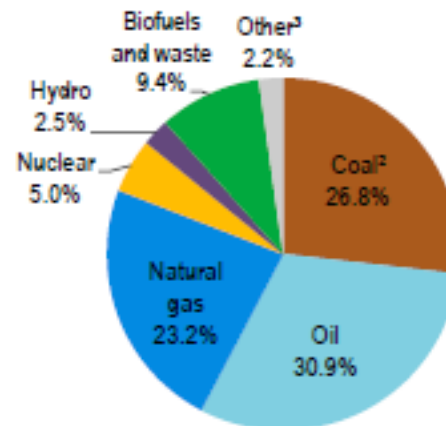

The World Energy Balance

World

BALANCE (2019)

Petajoules ▾

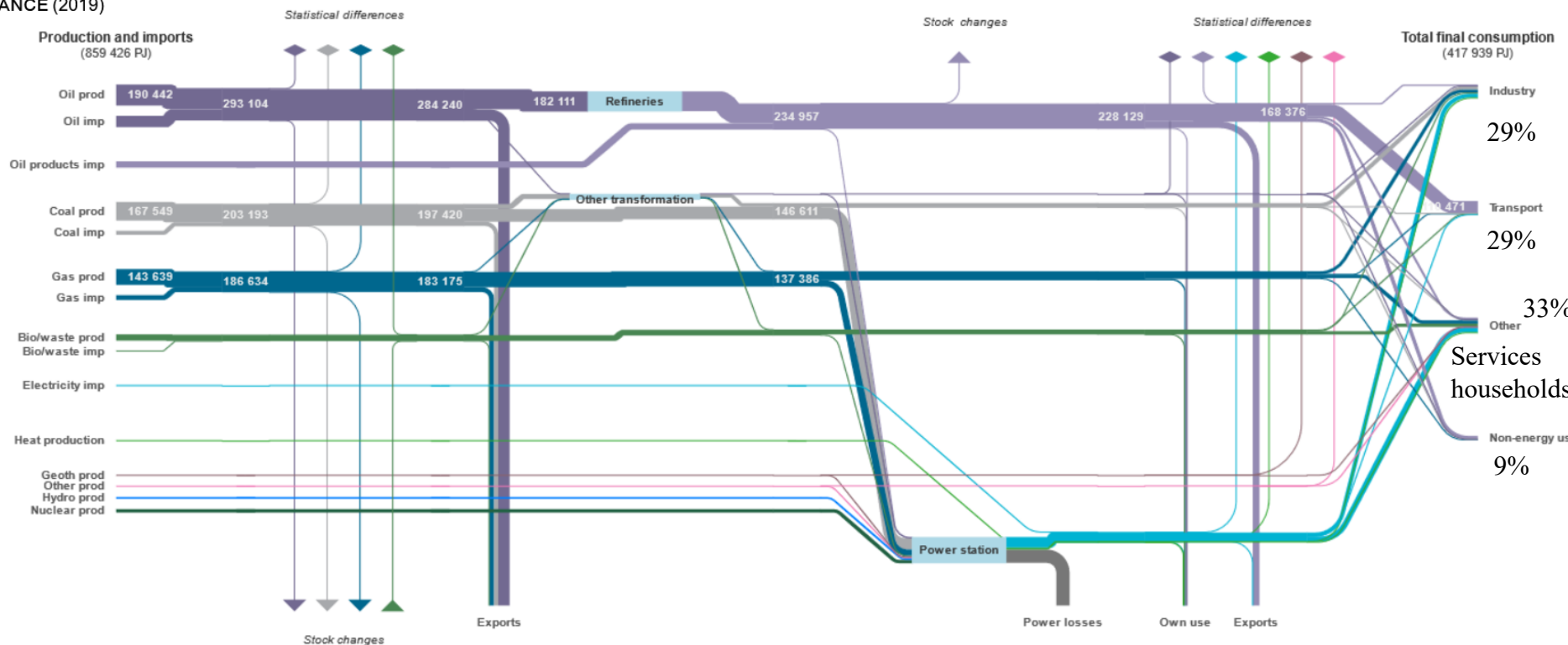

72% of electricity is fossil based
52% losses in electricity generation

Soon back: <http://www.iea.org/Sankey/>

Oil reserves

BP World energy statistics review 2021

Reserves-to-production (R/P) ratios

Years

2020 by region

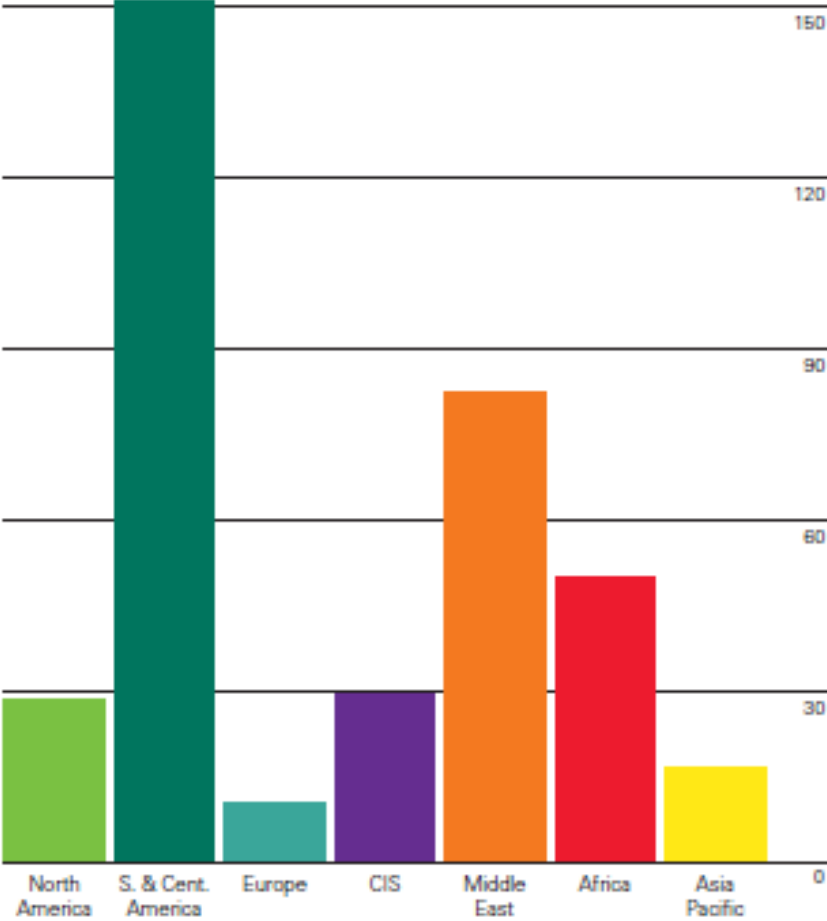

History

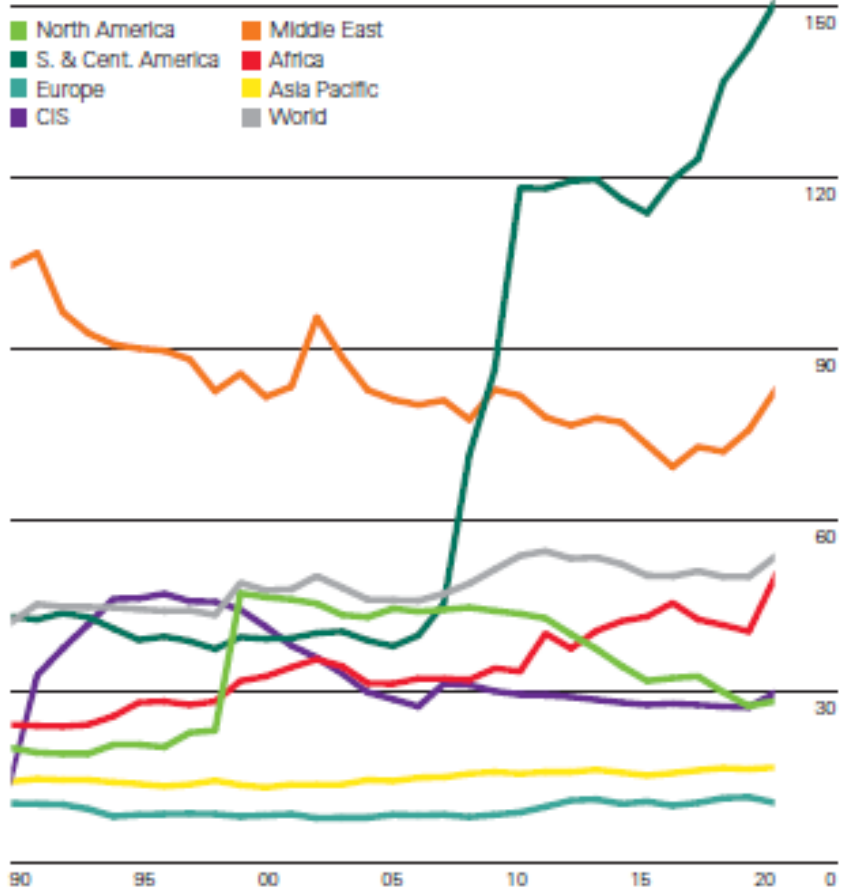

Global proved oil reserves were 1732 billion barrels at the end of 2020, down 2 billion barrels versus 2019. The global R/P ratio shows that oil reserves in 2020 accounted for over 50 years of current production. OPEC holds 70.2% of global reserves. The top countries in terms of reserves are Venezuela (17.5% of global reserves), closely followed by Saudi Arabia (17.2%) and Canada (9.7%).

Gas reserves

Reserves-to-production (R/P) ratios

Years

2020 by region

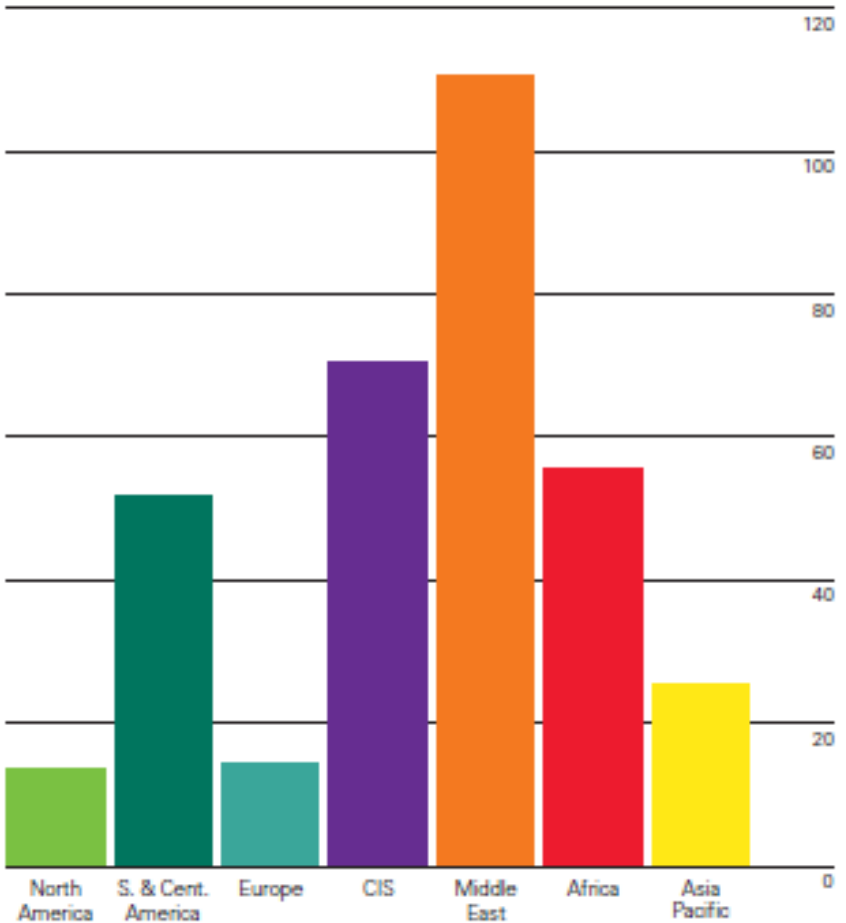

History

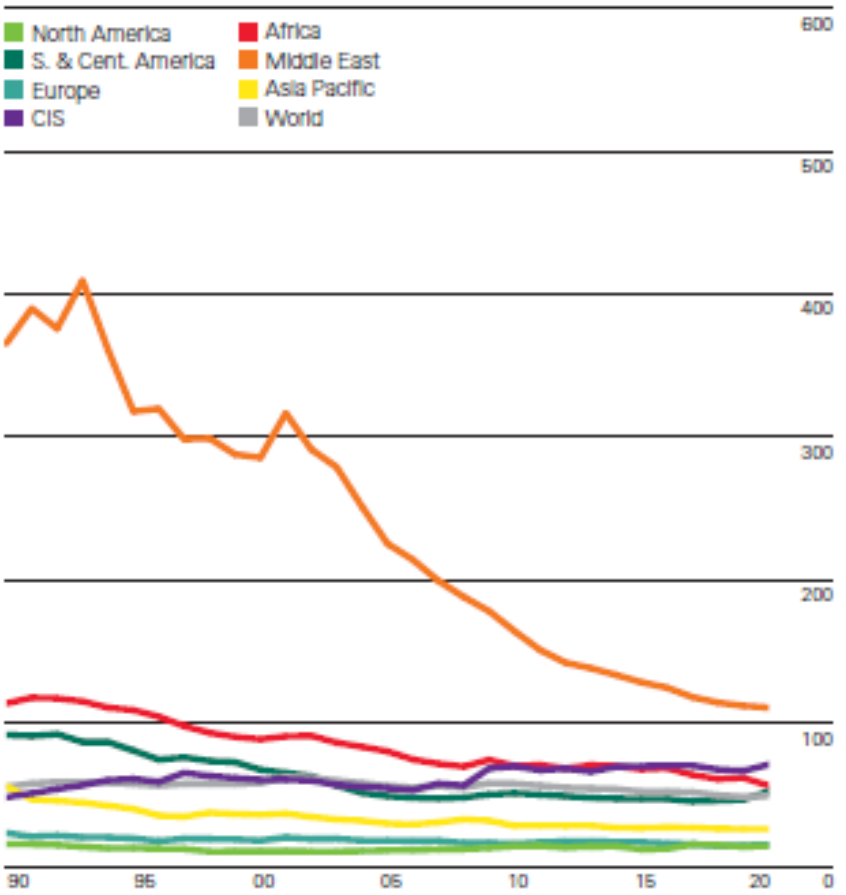

World proved gas reserves decreased by 2.2 Tcm to 188.1 Tcm in 2020. A revision to Algeria (-2.1 Tcm) provided the largest decrease, partially offset by a 0.4 Tcm increase in Canadian reserves. Russia (37 Tcm), Iran (32 Tcm) and Qatar (25 Tcm) are the countries with the largest reserves. The current global R/P ratio shows that gas reserves in 2020 accounted for 48.8 years of current production. The Middle East (110.4 years) and CIS (70.5 years) are the regions with the highest R/P ratio.



Coal reserves

Reserves-to-production (R/P) ratios
Years

2020 by region

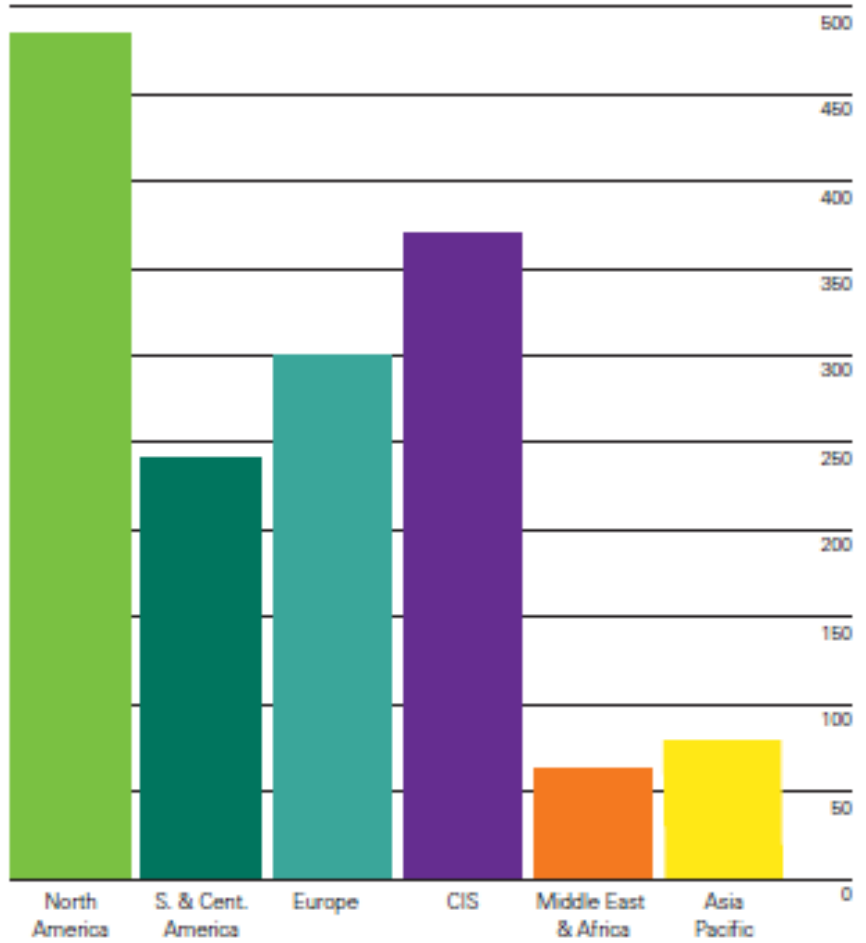

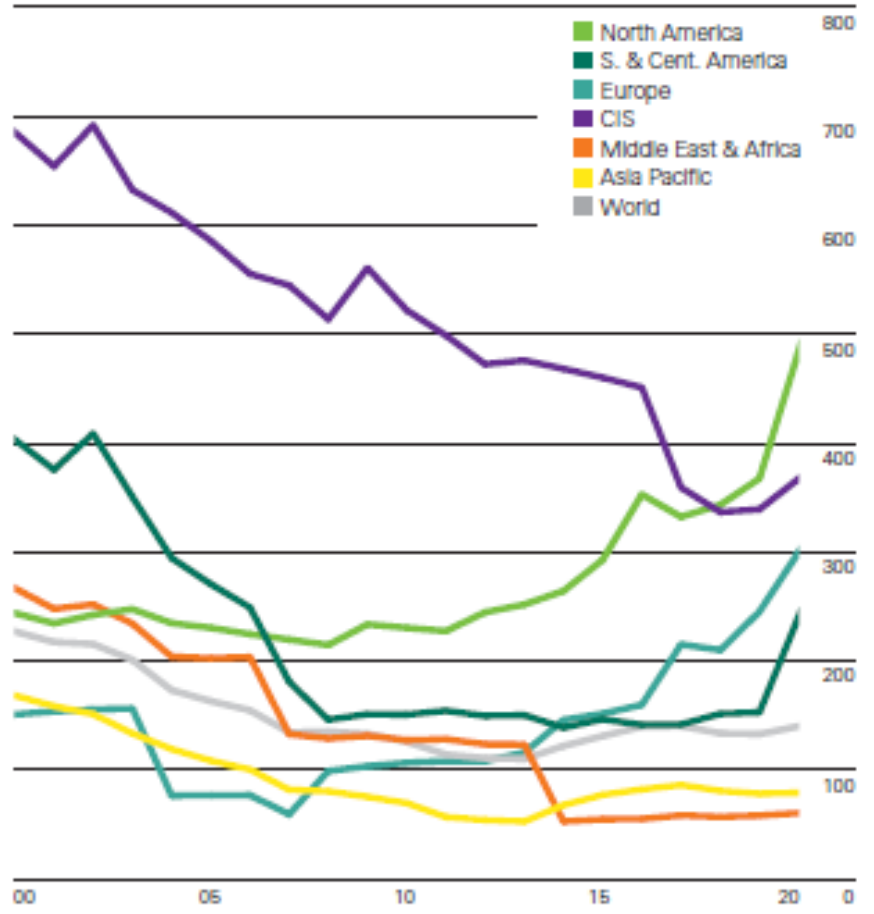

History

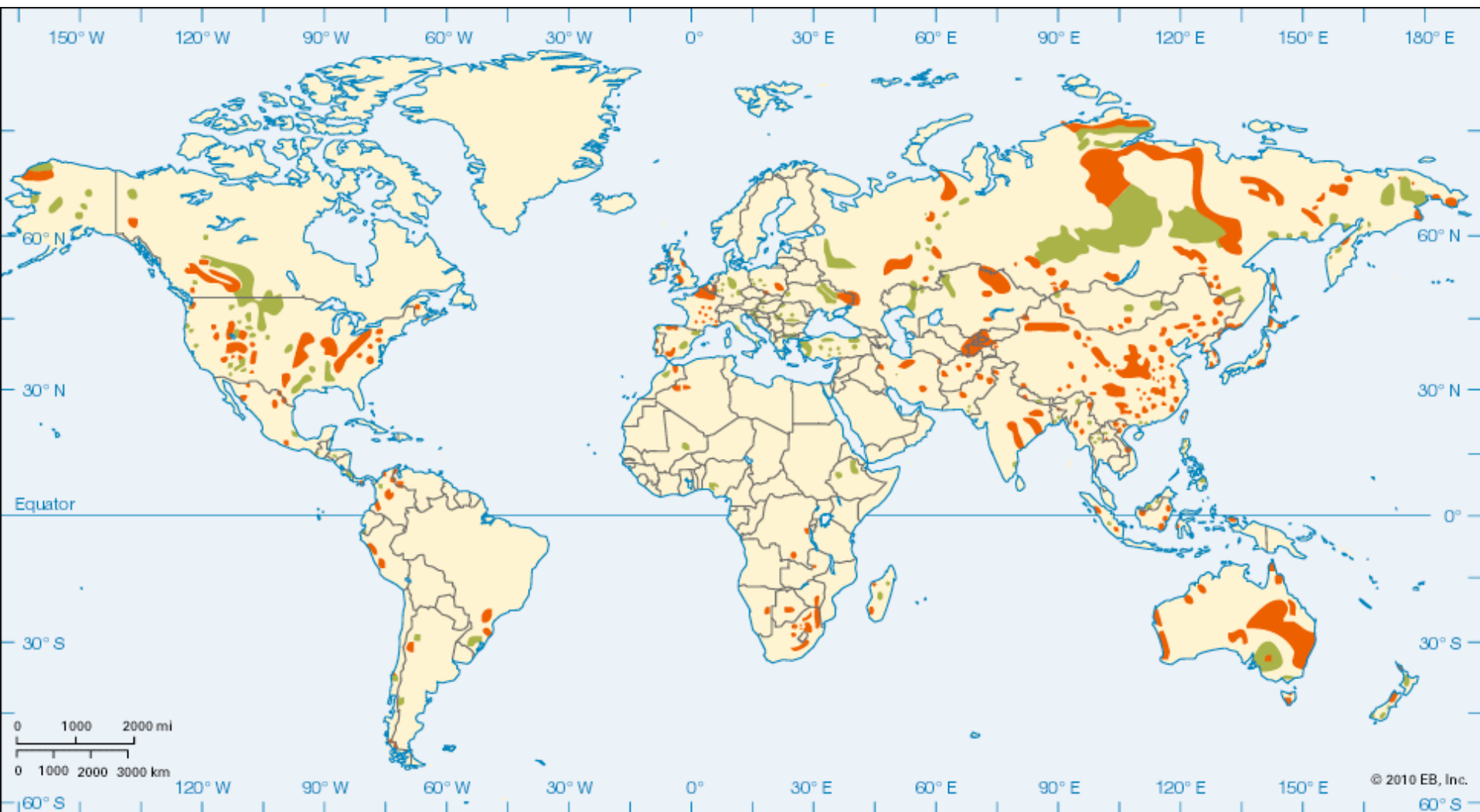

World coal reserves in 2020 stood at 1074 billion tonnes and are heavily concentrated in just a few countries: US (23%), Russia (15%), Australia (14%) and China (13%). Most of the reserves are anthracite and bituminous (70%). The current global R/P ratio shows that coal reserves in 2020 accounted for 139 years of current production with North America (484 years) and CIS (367 years) the regions with the highest ratios.

Coal mines in the world



 Anthracite and Bituminous Coal  Lignite

Coal

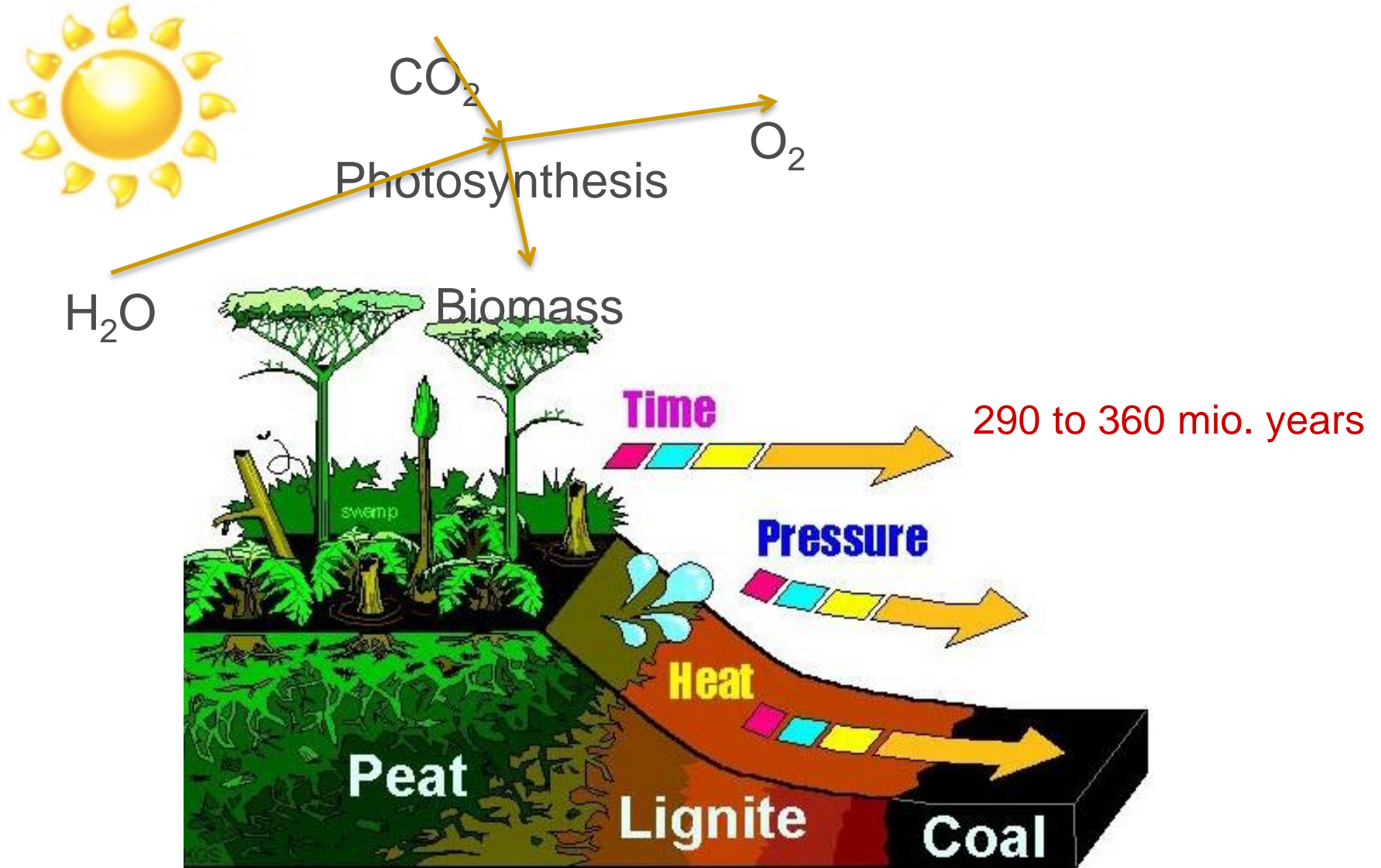

Coal

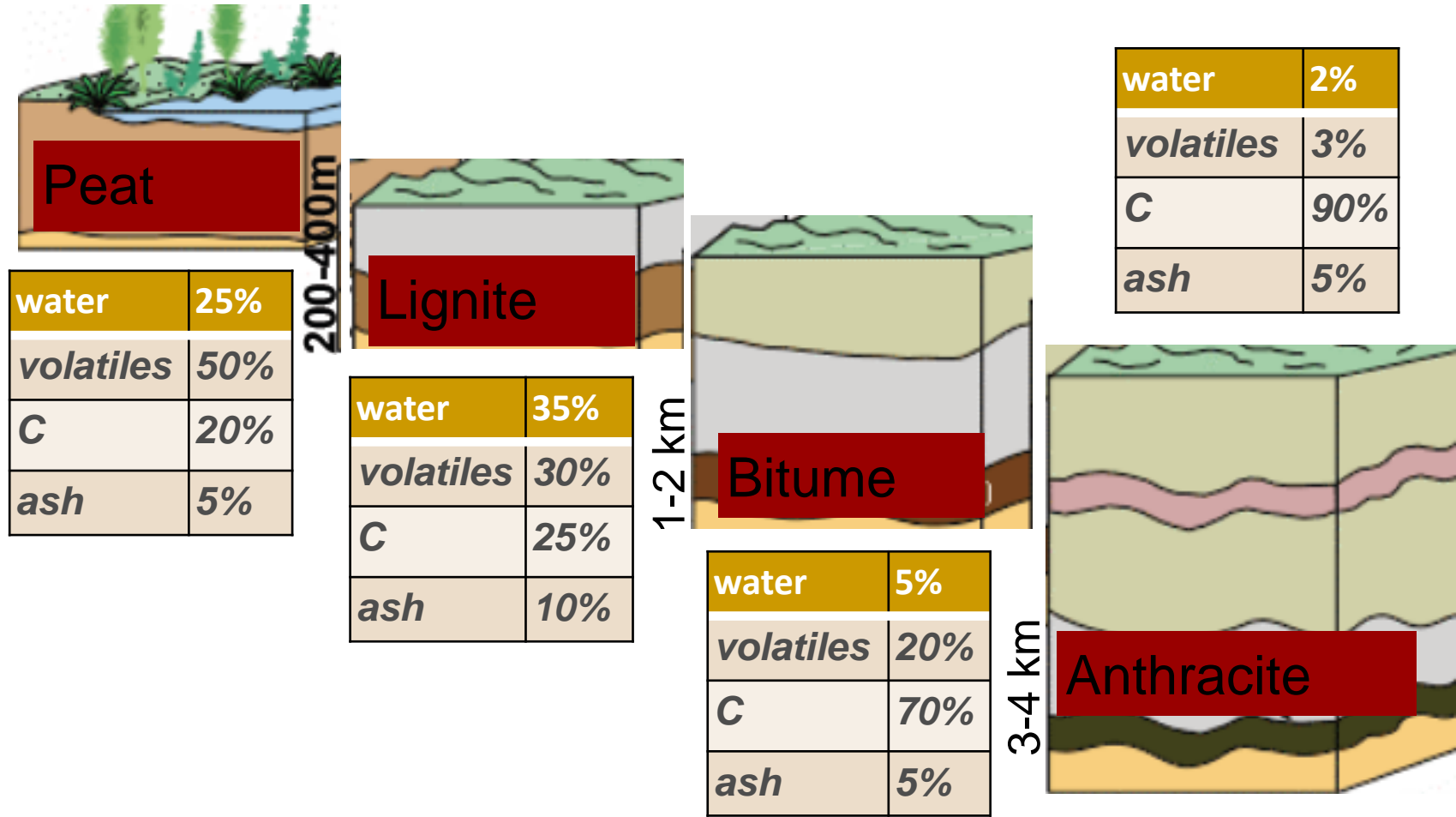

Energy



14GJ/tonne 19GJ/tonne 24-30GJ/tonne 30-32GJ/tonne

Liquid and gas fuels

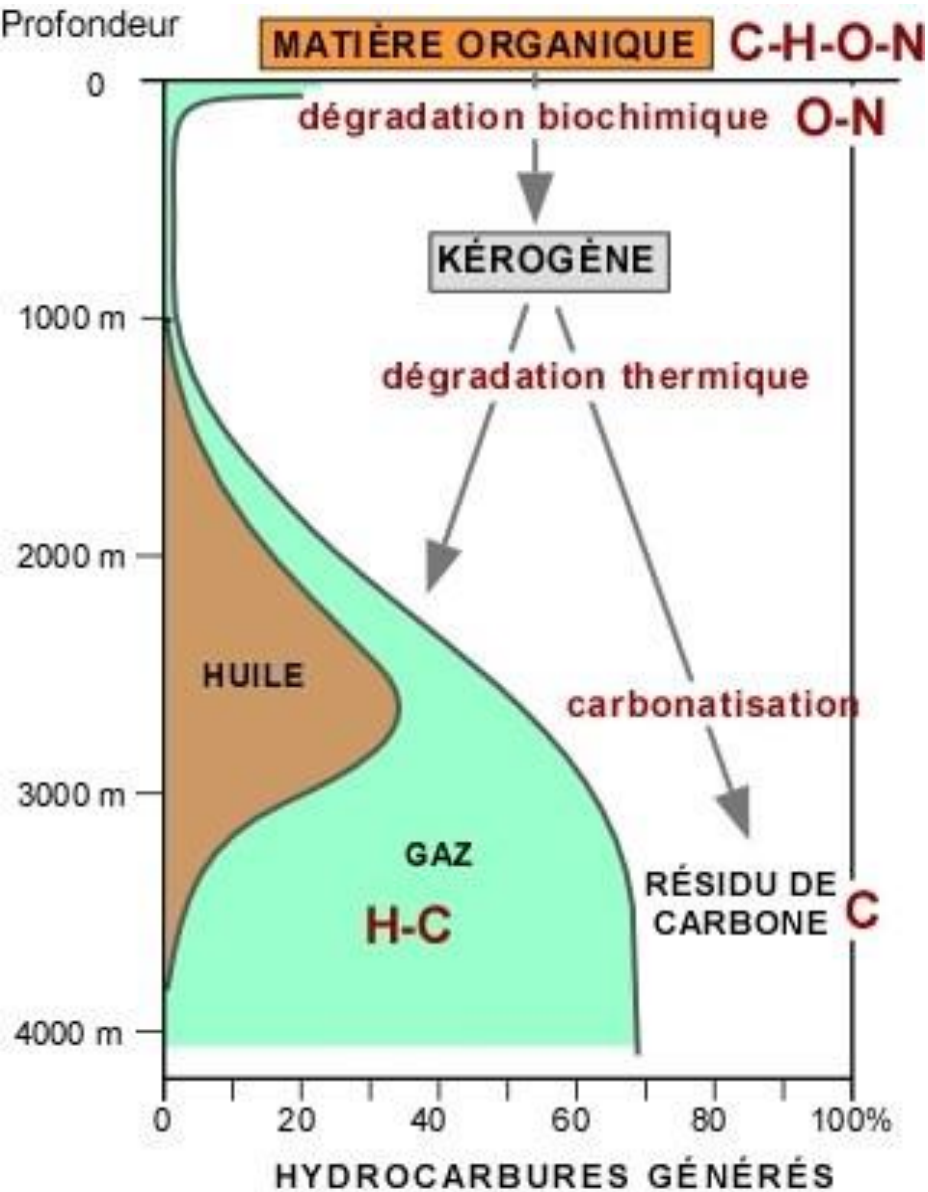

In the first 1 km, bacteria convert organic matter into kerogen (embryonic oil).

> 1 km, burying leads to a gradual transformation of the sediment rock and thermal degradation ($\sim 100^{\circ}\text{C}$) of kerogen.

Between 2 and 3 km, this is where the kerogen produces a lot of oil.

At 3.5 km, less to none oil is produced but lots of gas.

A geological cap captures the oil/gas

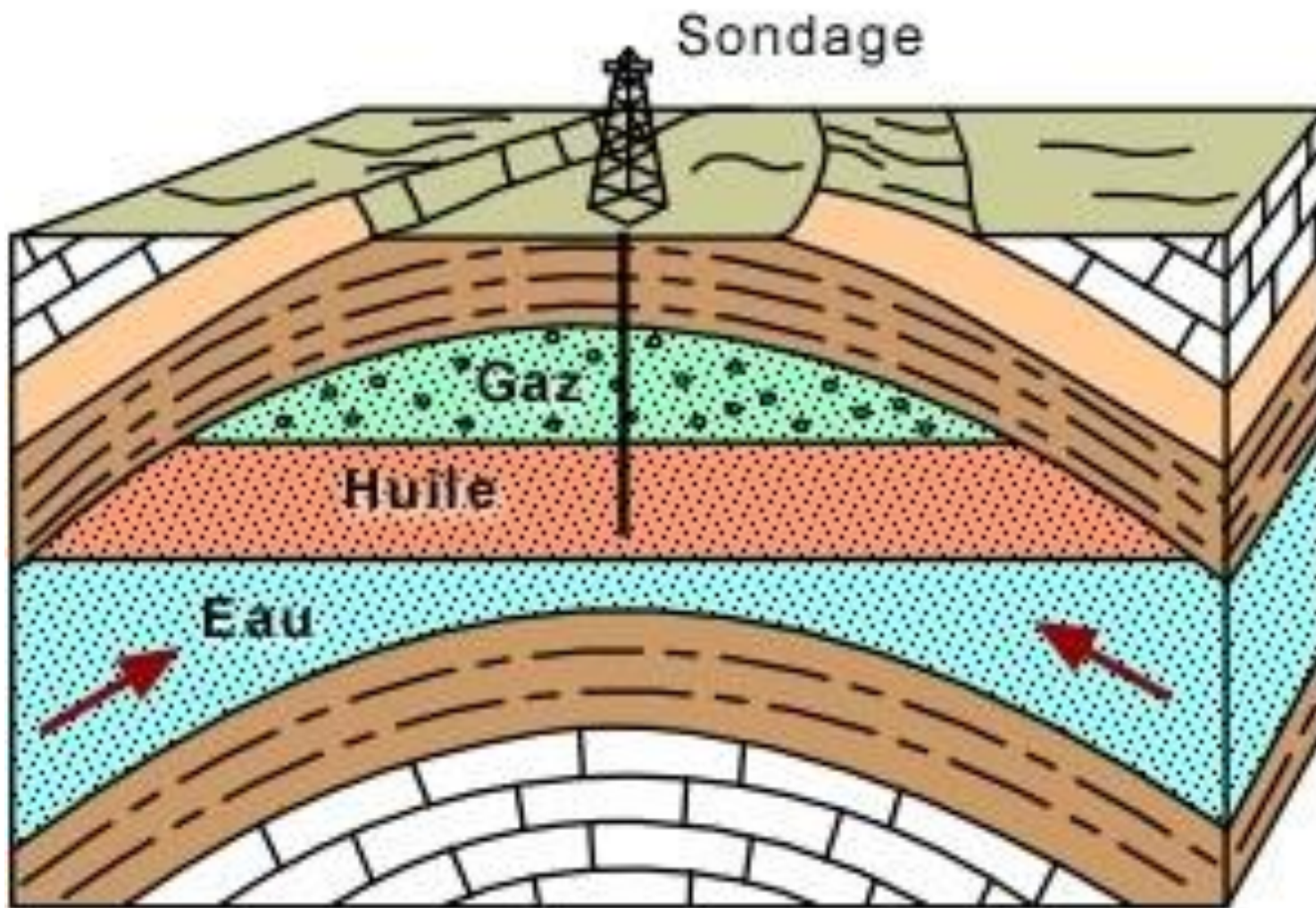

A - Piège structural: anticlinal

Drilling and extraction



Spontaneous extraction from the pressure of the well



Mechanical extraction

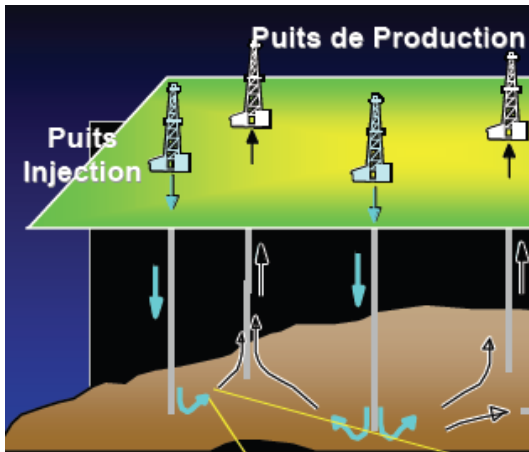

Enhanced oil and gas recovery by water/CO₂ injection
→ CO₂ sequestration

The biggest fields

Field Name	Country	Discovery year	Range of URR [Gb]
Ghawar	Saudi Arabia	1948	66-100
Burgan Greater	Kuwait	1938	32-60
Safaniya	Saudi Arabia	1951	21-36
Bolivar Coastal	Venezuela	1917	14-36
Berri	Saudi Arabia	1964	10-25
Rumalia N&S	Iraq	1953	22
Zakum	Abu Dhabi	1964	17-21
Cantarell Complex	Mexico	1976	11-20
Manifa	Saudi Arabia	1957	17
Kirkuk	Iraq	1927	16
Gashsaran	Iran	1928	12-15
Abqaiq	Saudi Arabia	1941	10-15
Ahwaz	Iran	1958	13-15
Marun	Iran	1963	12-14
Samotlor	Russia	1961	6-14
Agha Jari	Iran	1937	6-14
Zuluf	Saudi Arabia	1965	12-14
Prudhoe Bay	Alaska	1969	13

Field	Country	Discovery Year	Ultimate Recoverable Reserves [Gb]
Kashagan	Kazakhstan	2000	7-9
Azadegan	Iran	1999	6-9
Roncador	Brazil	1996	2.9
Cusiana/Cupiagua	Colombia	1991	1.6
Sihil	Mexico	1999	1.4
Ourhoud	Algeria	1994	1.2
Thunder Horse	US GoM	1999	1-1.5

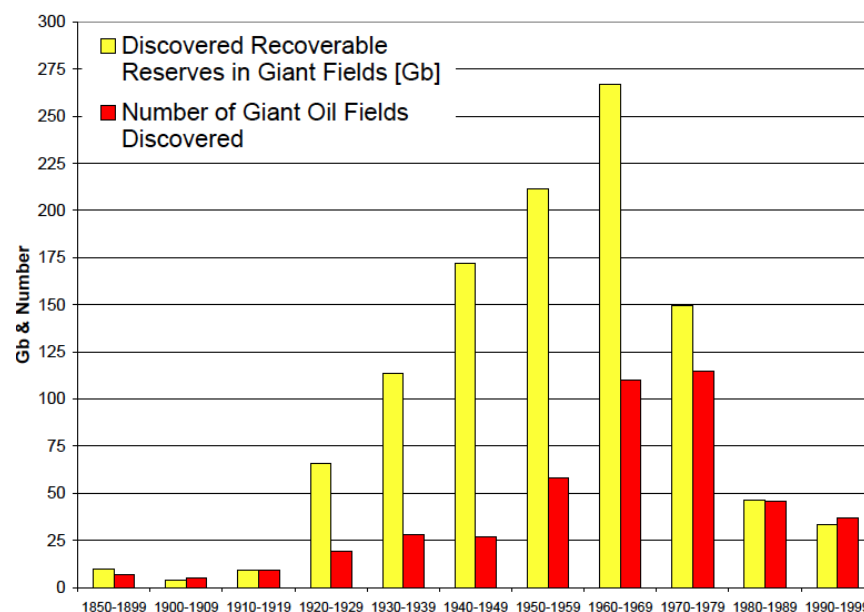

Source: AAPG, UHDSG

Oil refinery

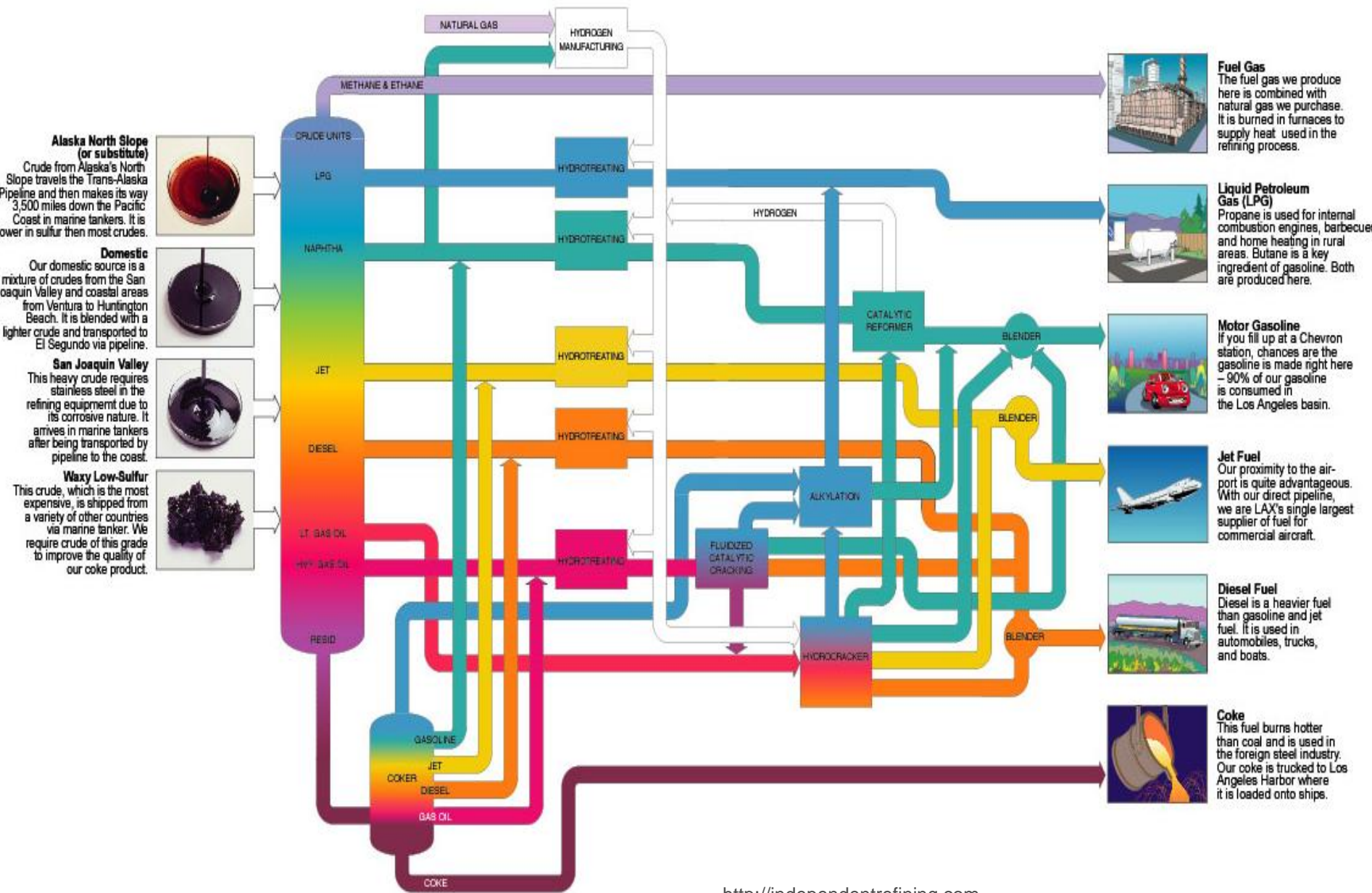

Natural gas

Top gas producing countries

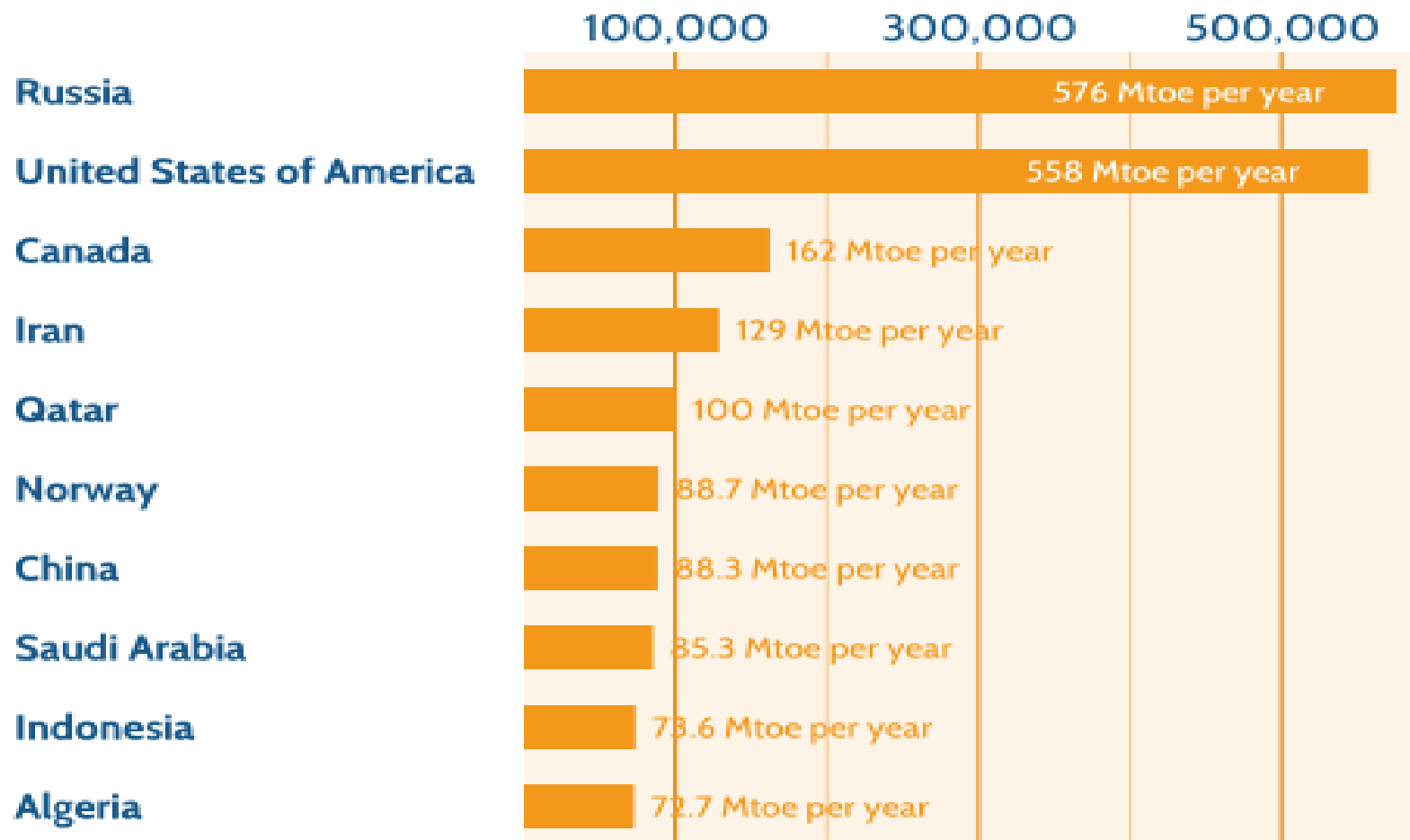

Copyright World Energy Council 2015

Non convention gas and oil

Hydraulic fracking: Oil and Gas

High pressure (500 bar) water

Tensio-active and biocide compounds to ease the extraction

Water is extracted and has to be treated

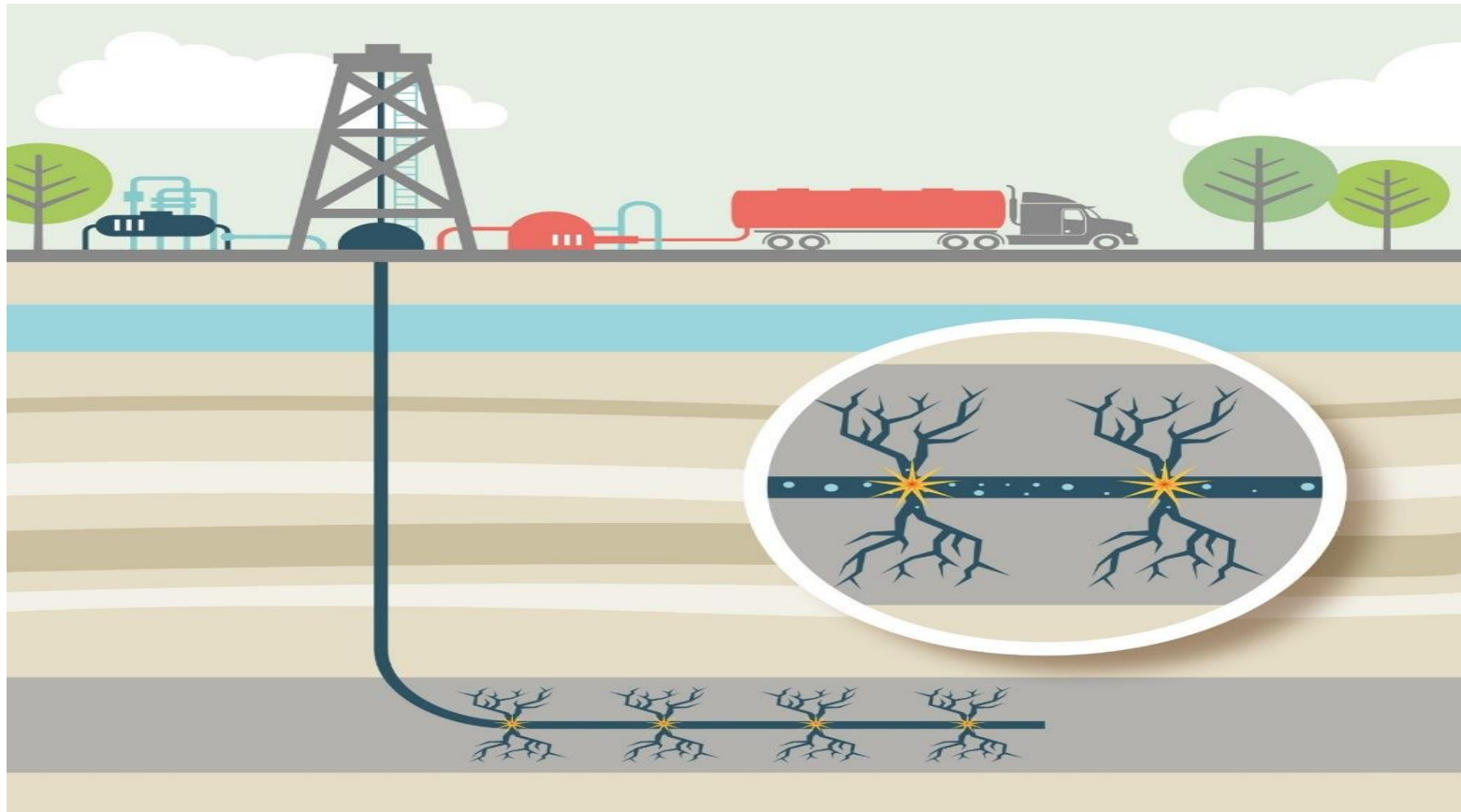

Who consumes the oil?

BP World energy statistics review 2021

Oil: Consumption per capita 2020

GJ per capita

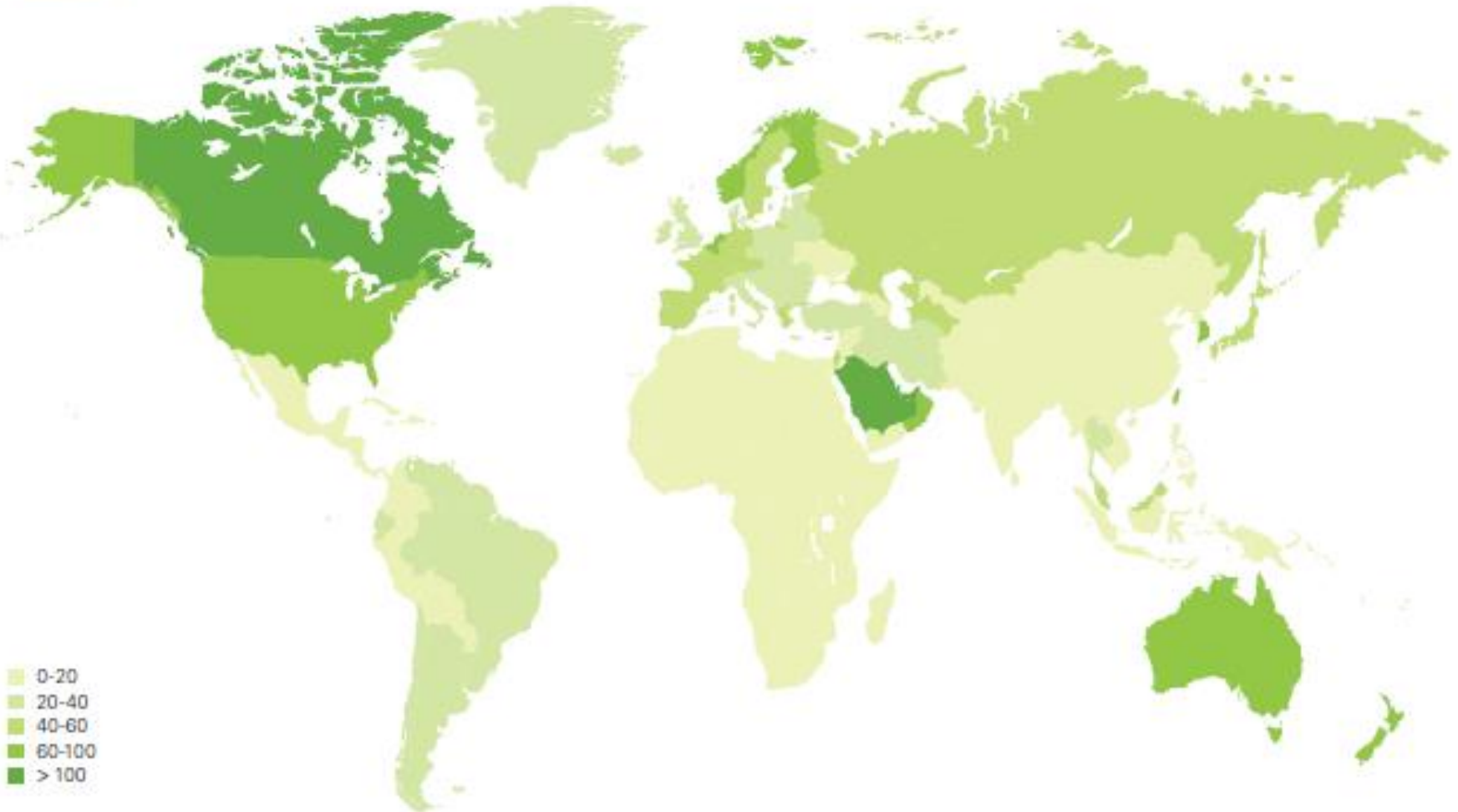

Who consumes the gas?

BP World energy statistics review 2021

Natural gas: Consumption per capita 2020

GJ per capita

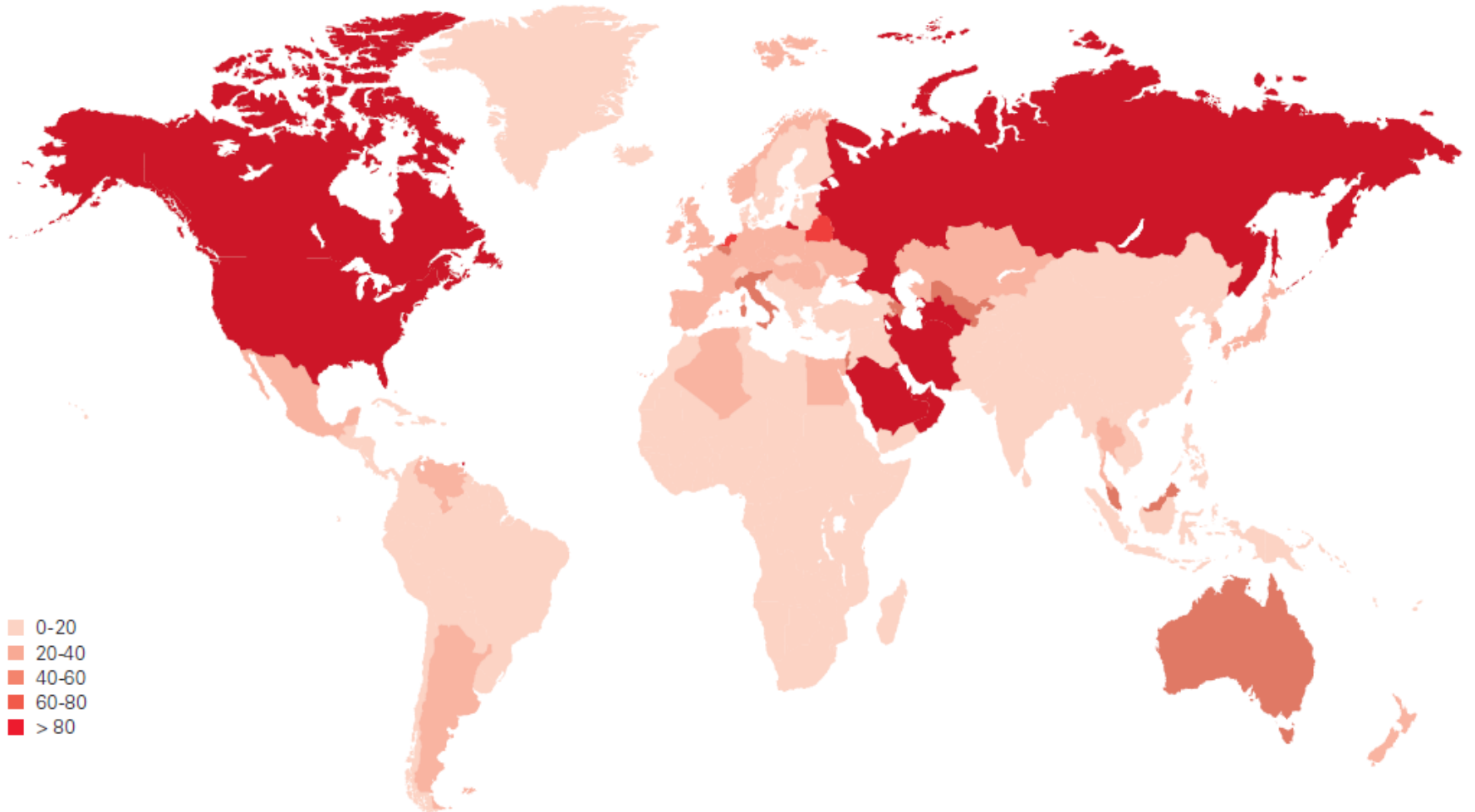

Who consumes the coal?

BP World energy statistics review 2013

Coal consumption per capita 2012 (Toe)

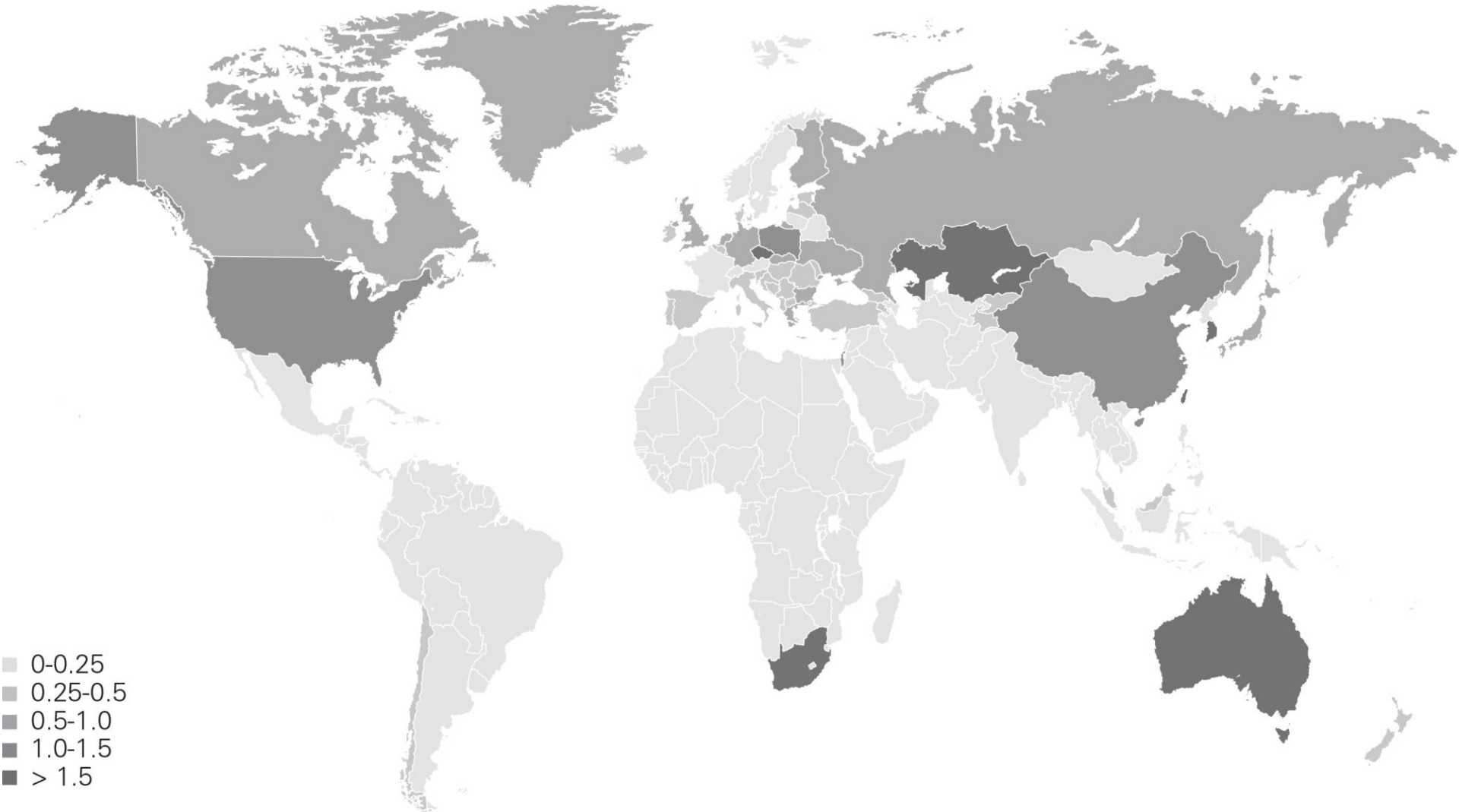

- 0-0.25
- 0.25-0.5
- 0.5-1.0
- 1.0-1.5
- > 1.5

Where is the overall primary energy consumption?

BP World energy statistics review 2013

Primary energy consumption per capita 2012 (Toe)

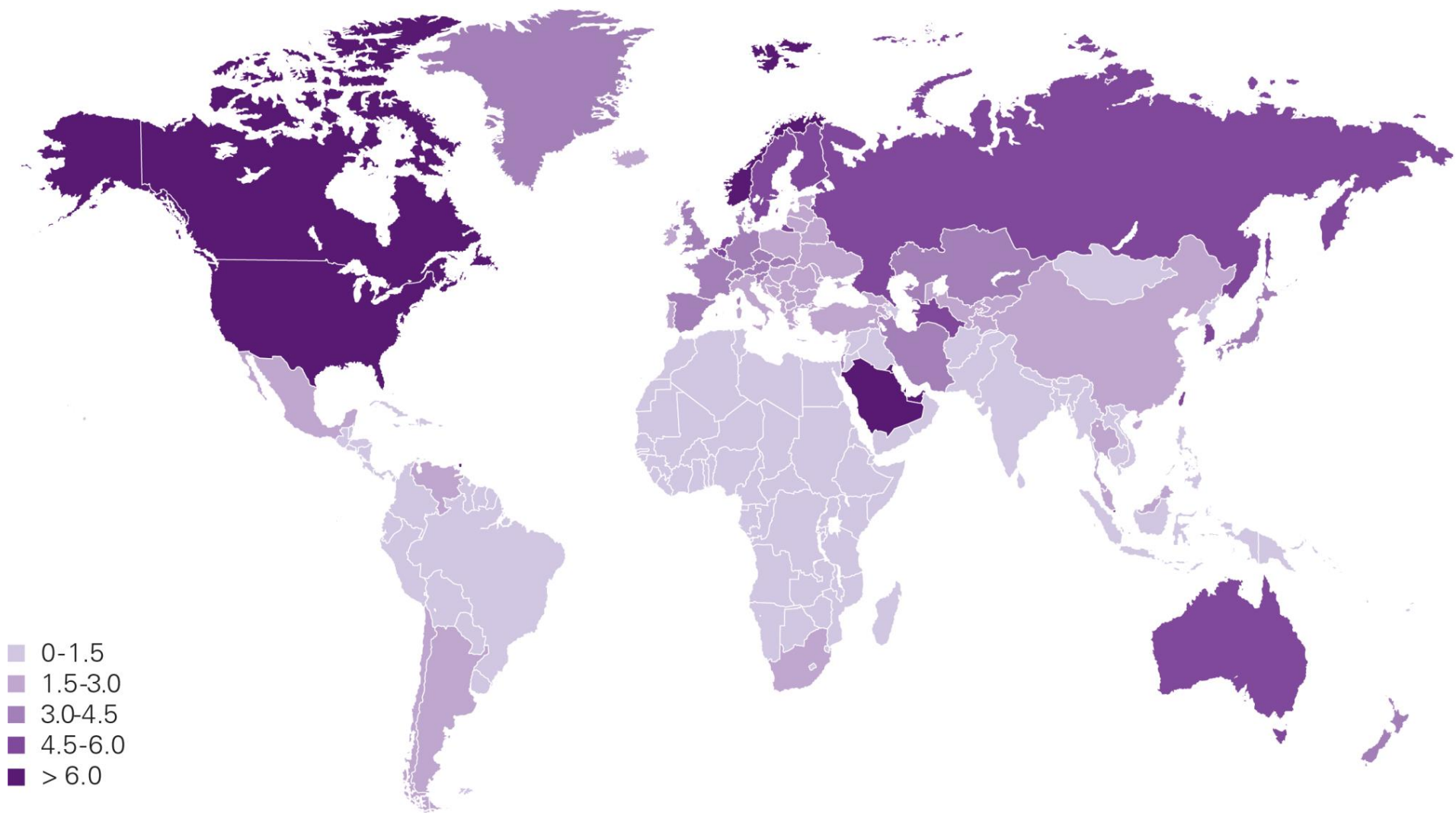

- 0-1.5
- 1.5-3.0
- 3.0-4.5
- 4.5-6.0
- > 6.0

'Reserves' and 'fuel cost'

- The given reserves are proven and valid for current production rates, at present **economics**
- **Ultimate** reserves (physical) could be 10x larger for coal and 4-5x larger for oil and gas, recoverable at higher **cost**, and extending the use to several centuries
- Isn't renewable energy, by contrast, 'free' fuel?
- No! What matters is the **cost of harnessing** any fuel, anywhere (localization, extraction, storage, transport, conversion,...)
- In this way, only direct solar energy that warms your body could be considered free; else, when not considering the cost of harnessing, also gas, oil and coal are free fuels, made by nature!

Time scale for fuel generation and consumption

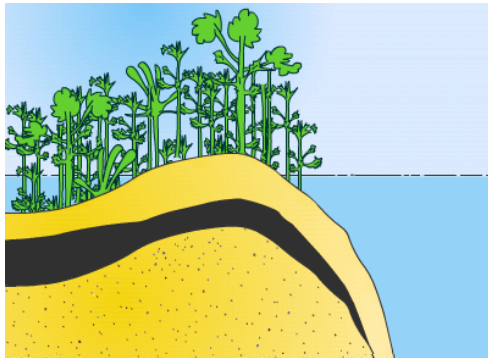

Generation time : 100 - 400 10^6 years

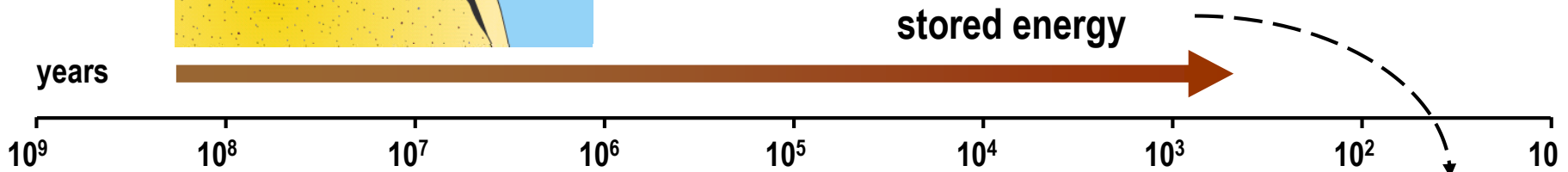

consumption time
 \ll generation time

\Rightarrow non-renewable

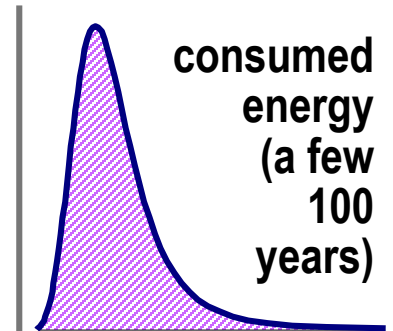
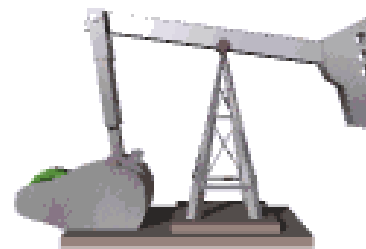

Renewable = sustainable

Fuel generation time \leq fuel consumption time

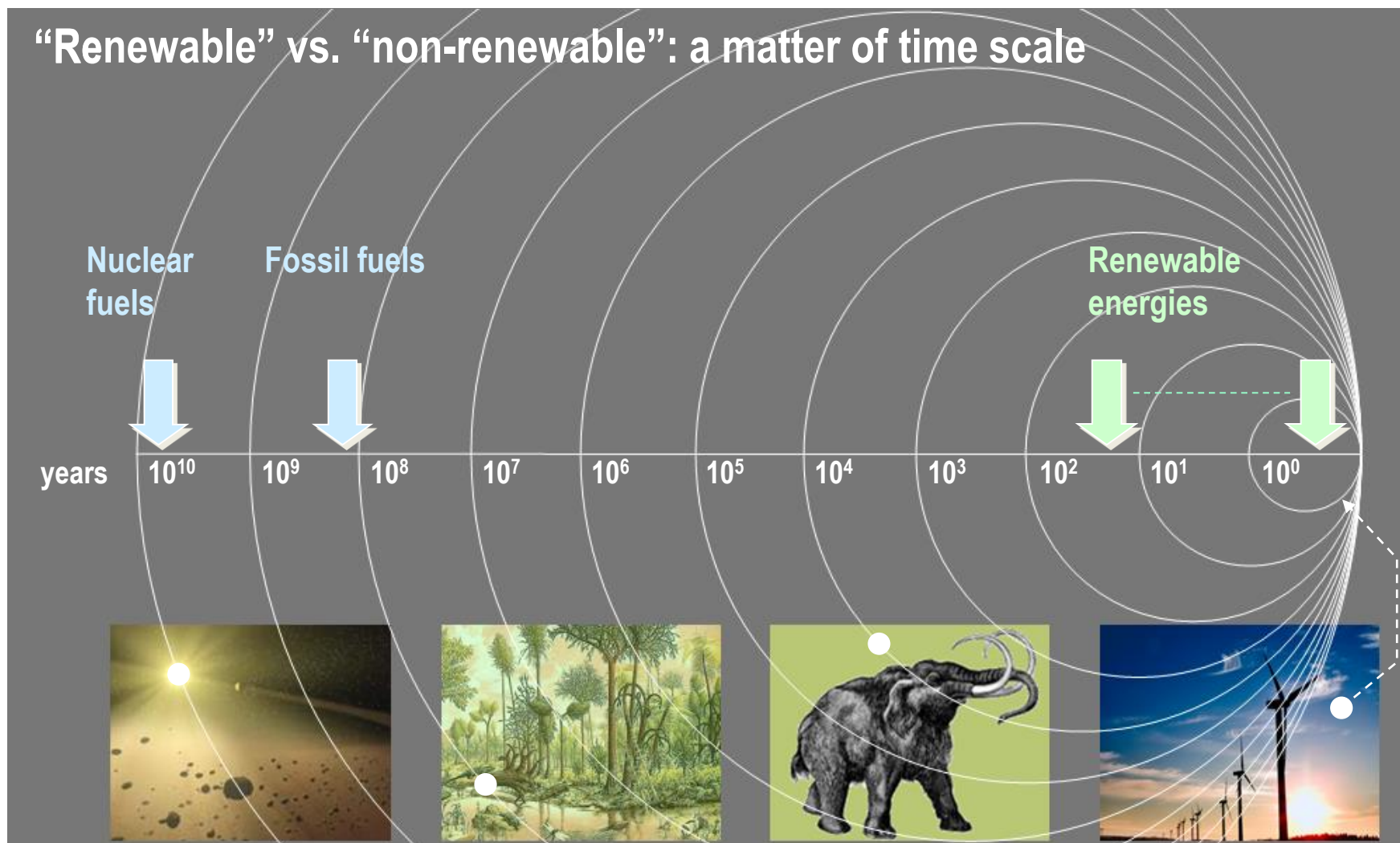

Non renewable = stored energy

Fossil (and nuclear) fuels are like energy **capital**, in the 'bank' for present use. Once used, it's no longer replenished on the life scale of mankind.



Renewable \approx energy fluxes (mostly unstored)

Unlike 'burning energy capital', we have to **harvest** these fluxes on a 'daily' basis for our energy '**income**'.

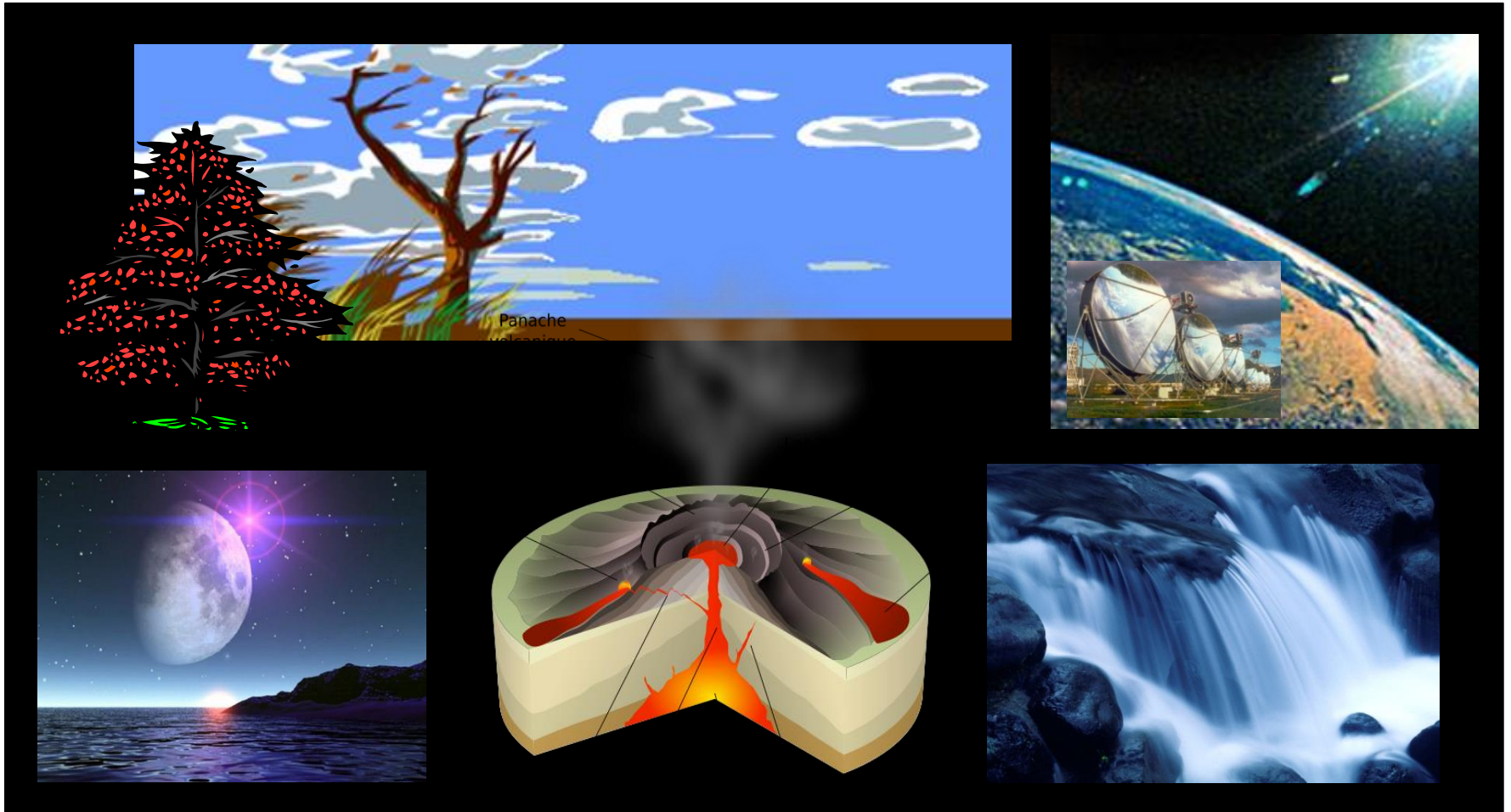

Classification w.r.t. timescale

Instantaneous use
(seconds, minutes)

Short term storage
(days, weeks)

Medium term storage
(months, years)

V. long term storage
(millions of years)

SOLAR – DIRECT

WIND

BIOMASS

OIL

SOLAR – THERMAL

HYDRO

WASTES

GAS

SOLAR – P.V.

WAVES

GEOTHERMAL

COAL

WIND

TIDES

NUCLEAR

HYDRO

GEOTHERMAL

Classification w.r.t. origin

$$E = mc^2$$

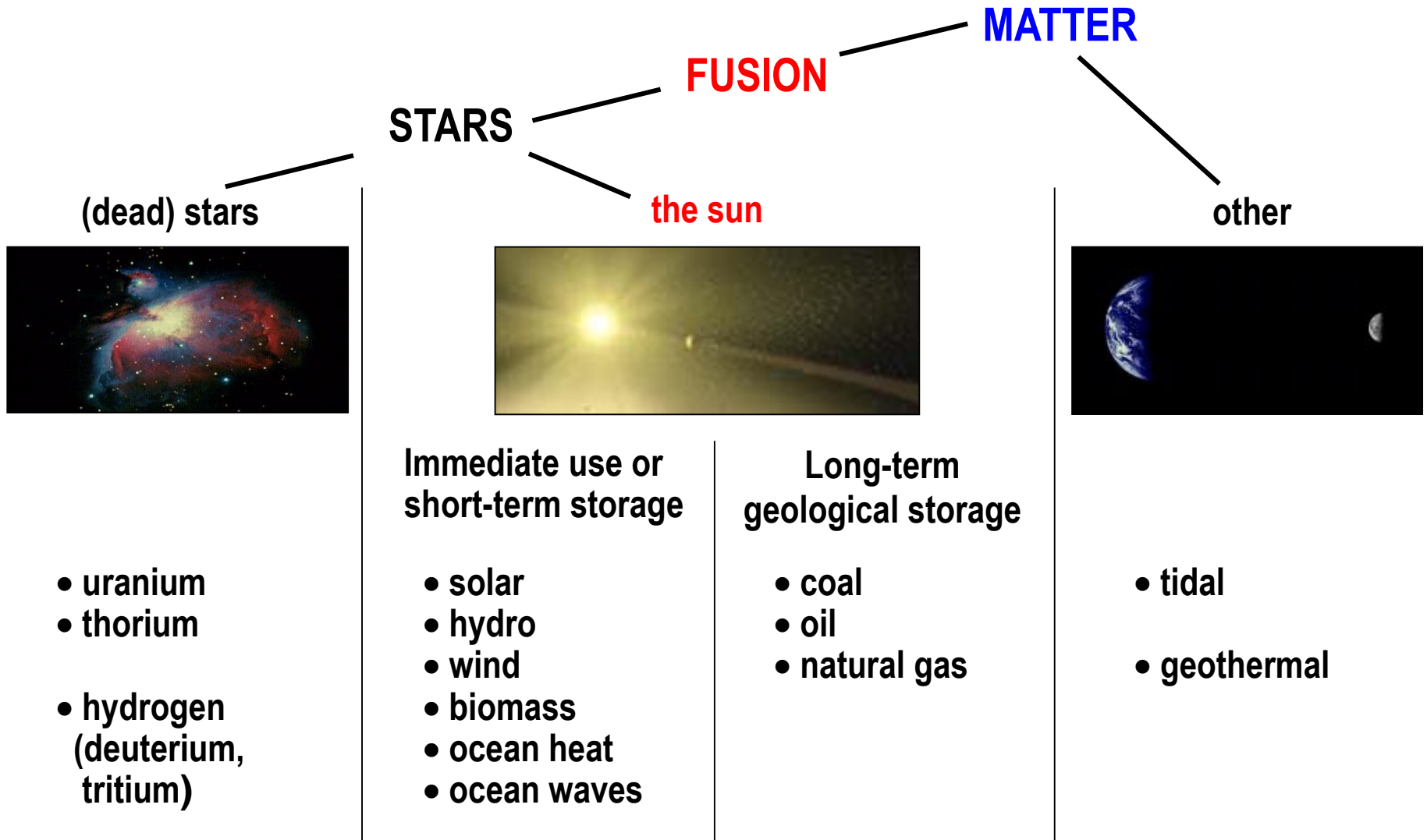

Humankind and energy: ever on the rise

From renewable to fossil energies
 ... and back to renewable ?

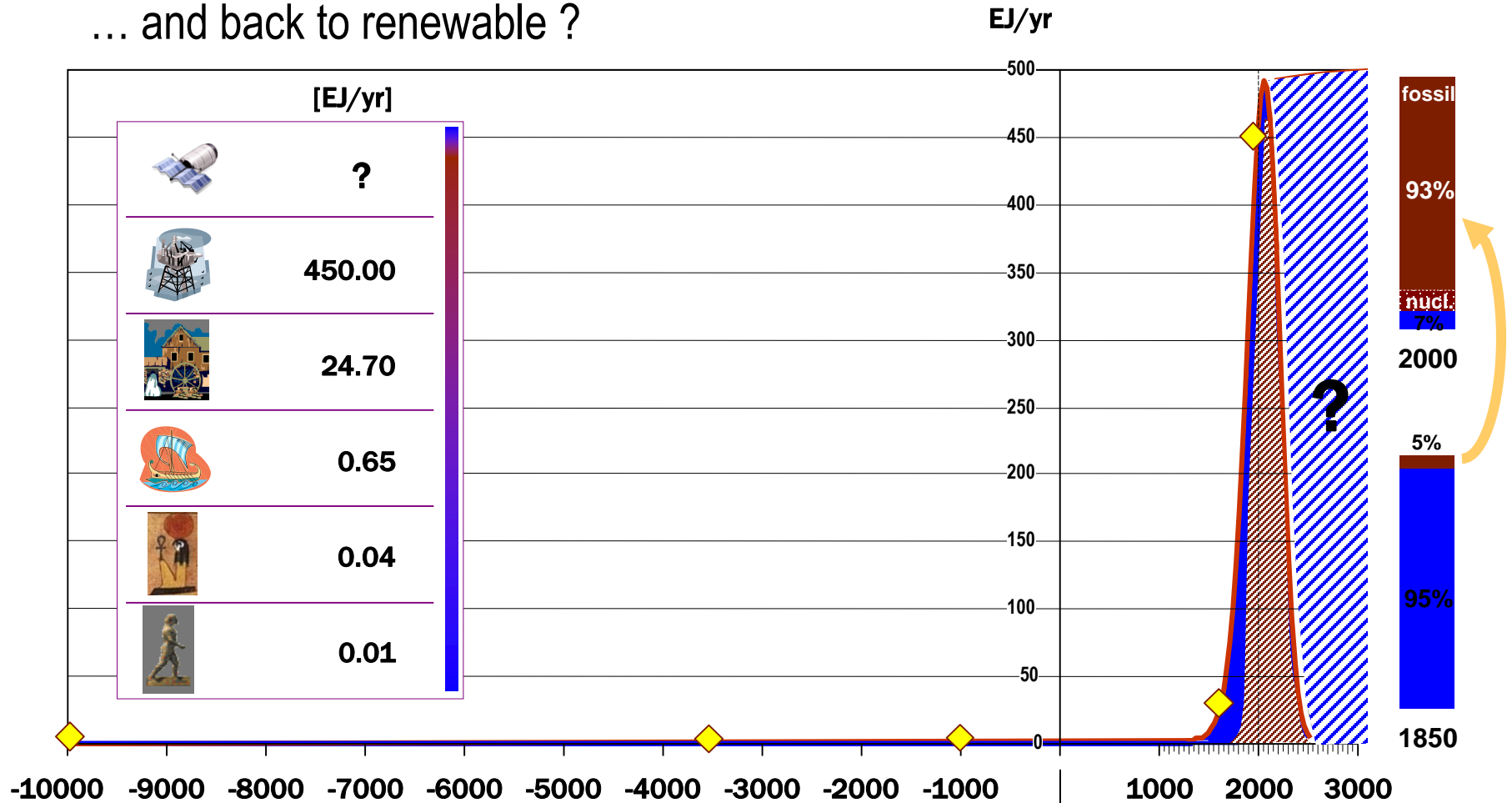

Main drivers for rise in energy demand

Demographic growth...

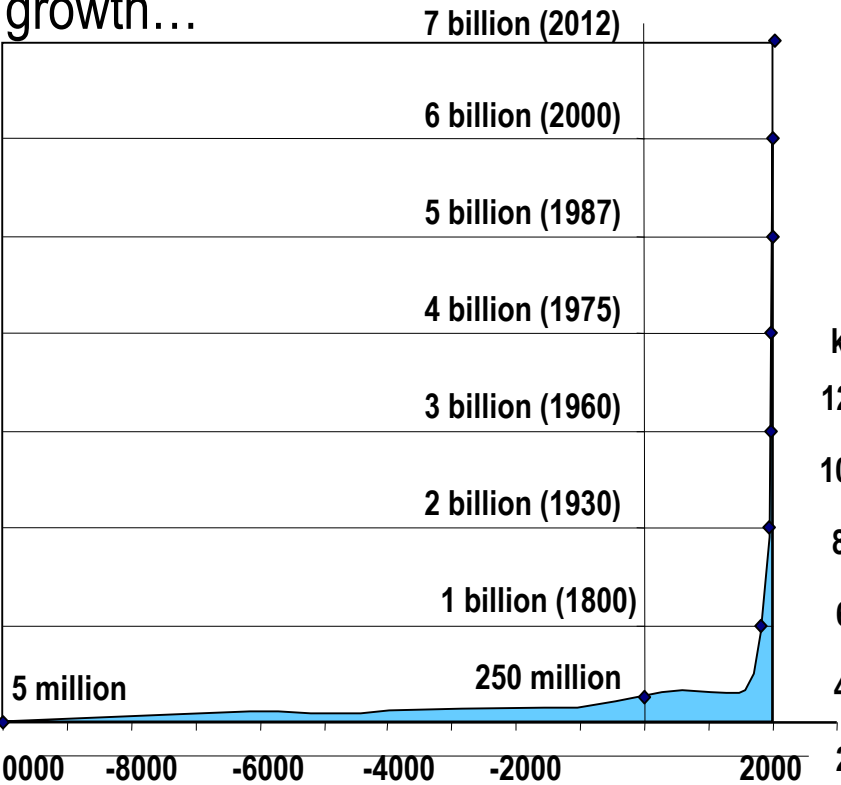

..X..

...improvement of standard of living (e.g. BIP) ...

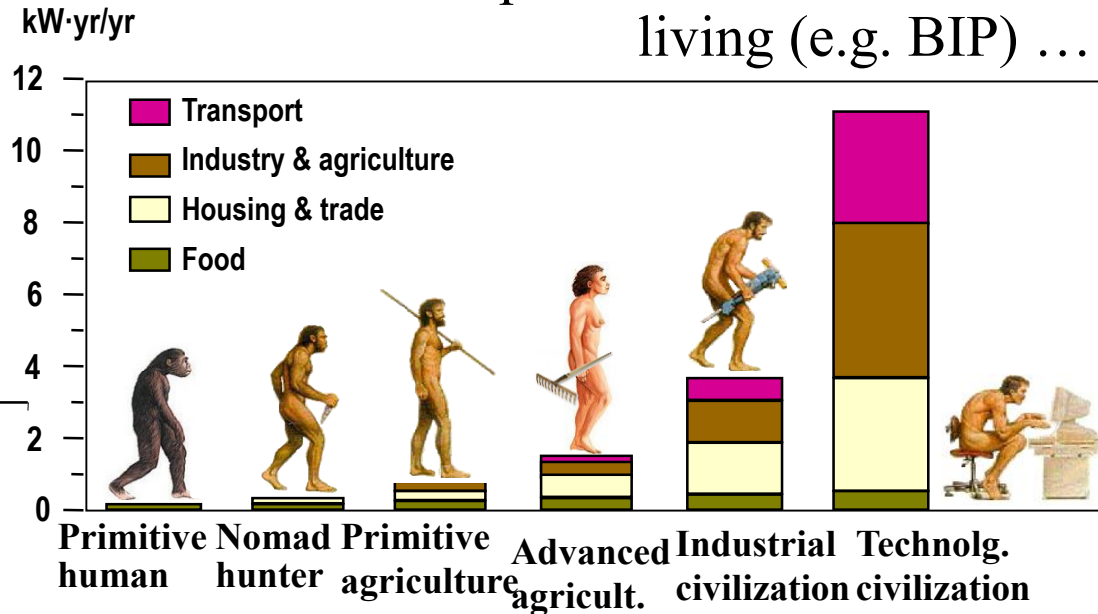

..X..

.. Energy intensity of energy service

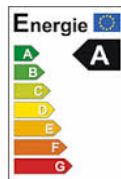

Sustainability

Not only a 'source' issue, but now even more a 'sink' issue !

consumption rate >>> generation rate

emissions rate > 'recovery' rate

Burning of energy capital

Production [10^9 barrels/yr]

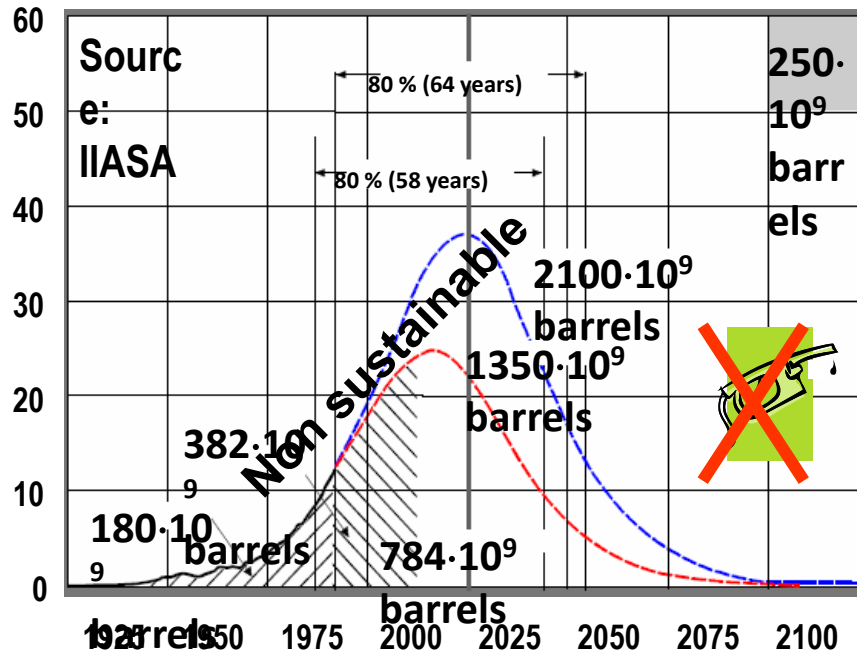

Irreversible damageable impacts on the environment

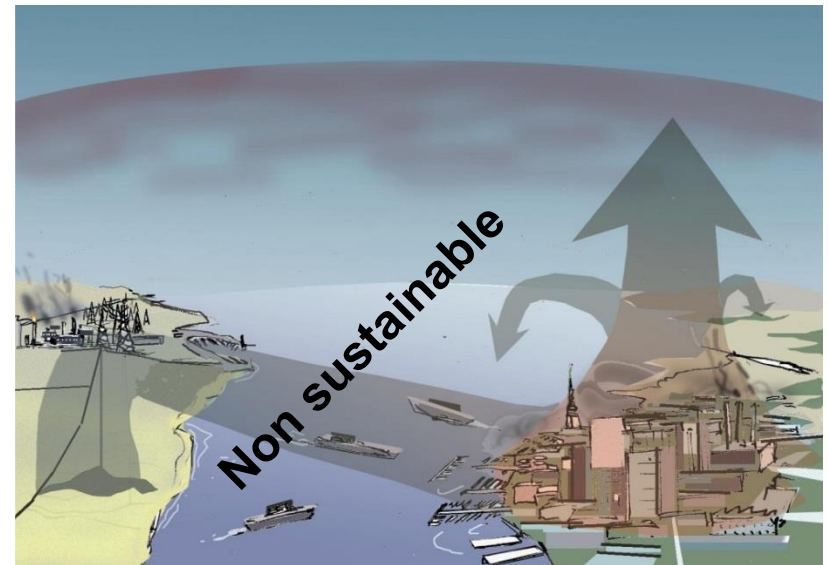

The sink: anthropogenic climate change

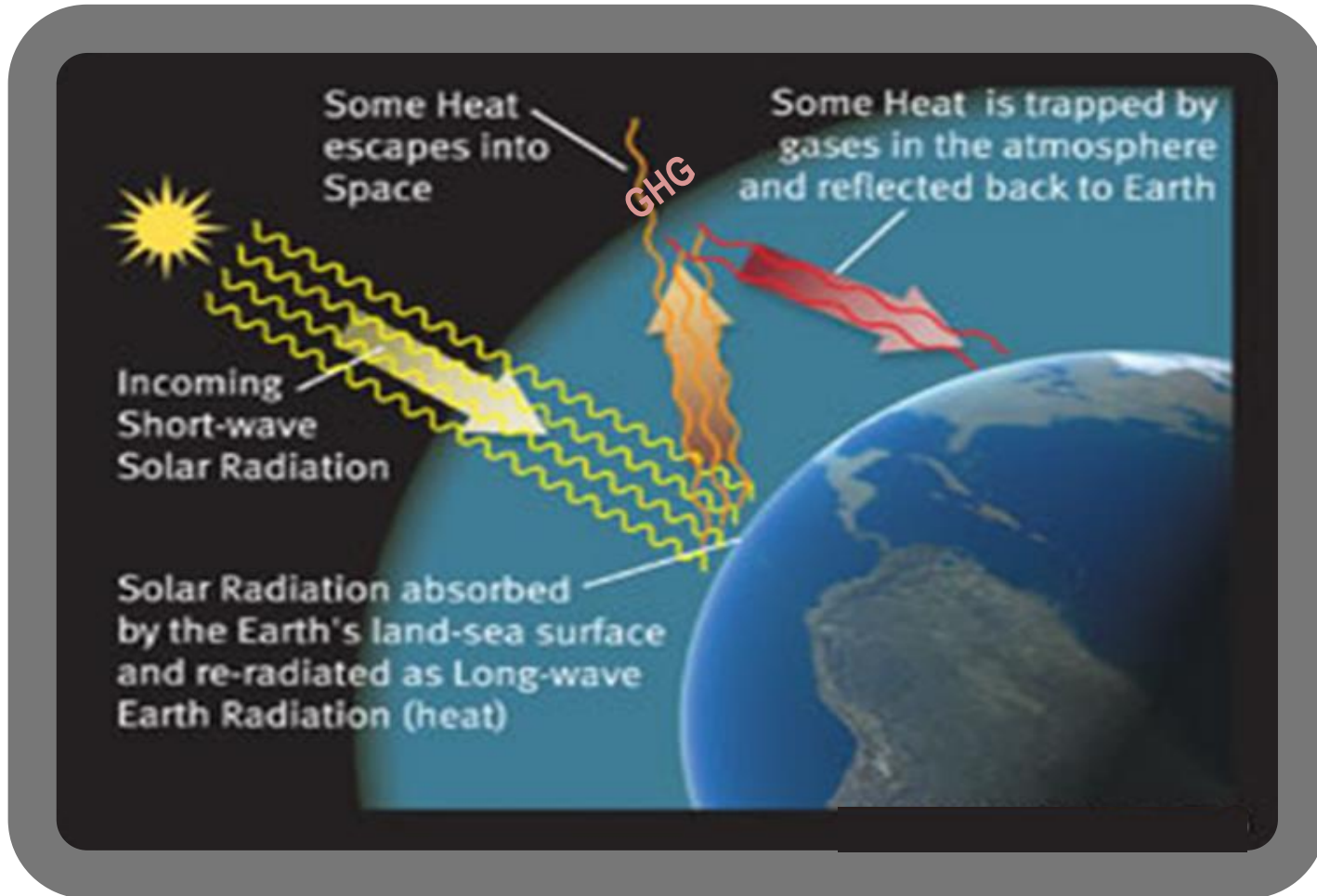

The green house effect

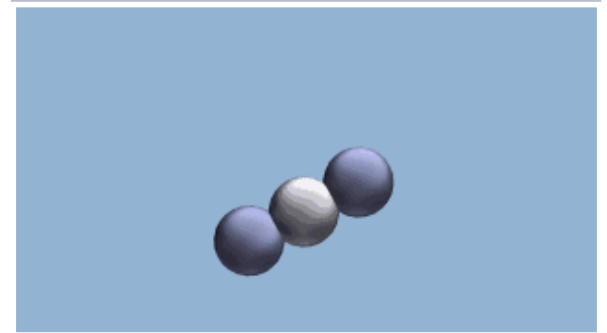
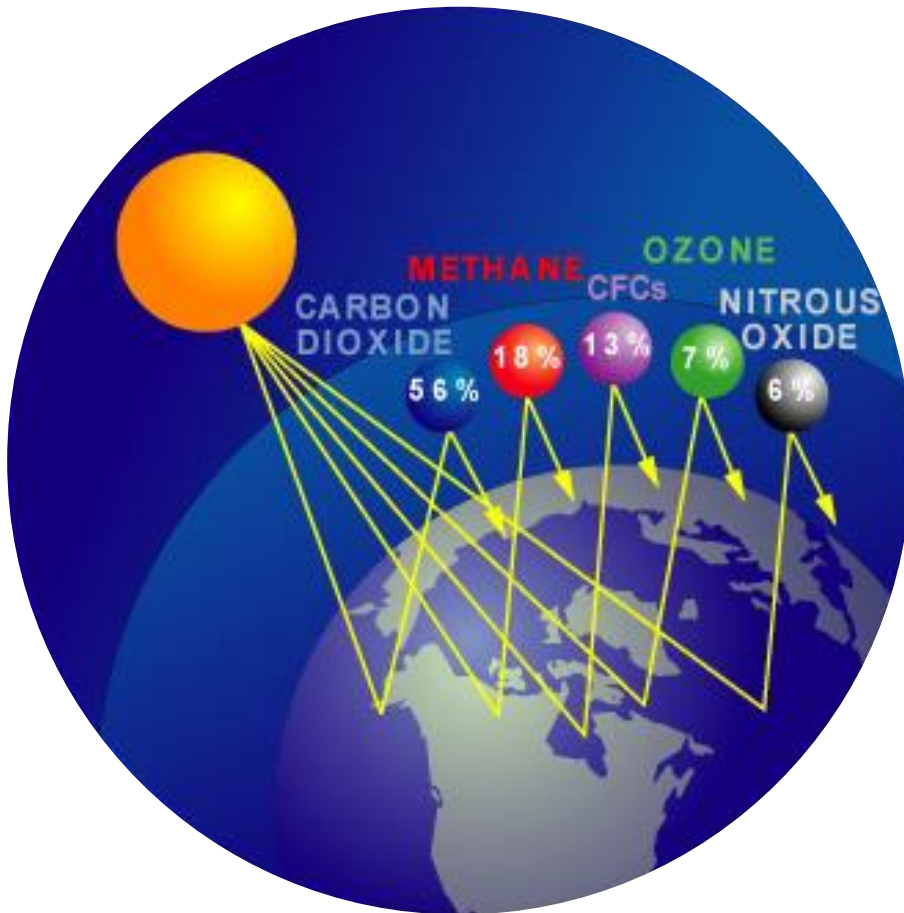

CO₂ absorbs IR radiation in its vibration states. The vibrating molecule re-emits the radiation which is absorbed by another GHG molecule. This absorption - emission - absorption cycle keeps the heat near the surface, effectively insulating the Earth from cold Space.

**relative importance
of anthropogenic
greenhouse gases**

Global warming is for at least half due to energy use

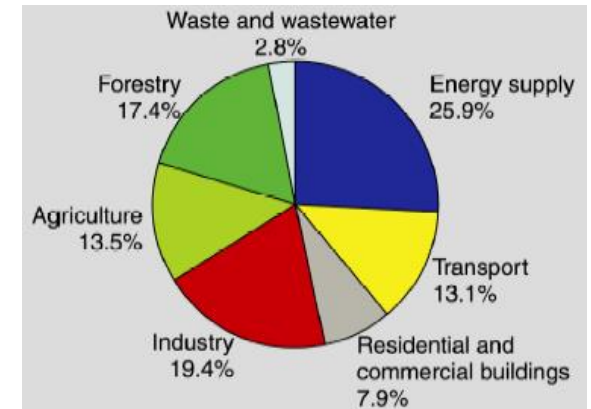
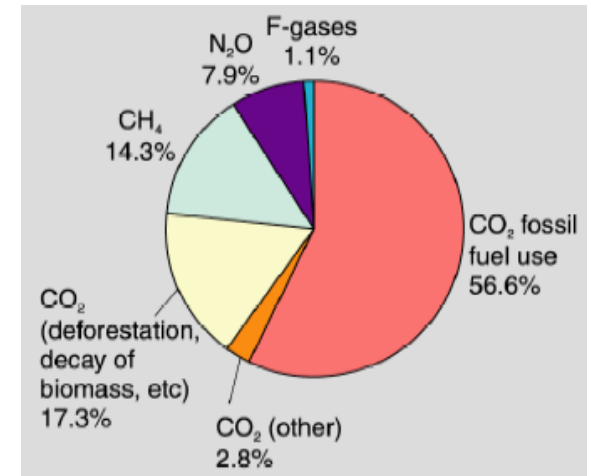
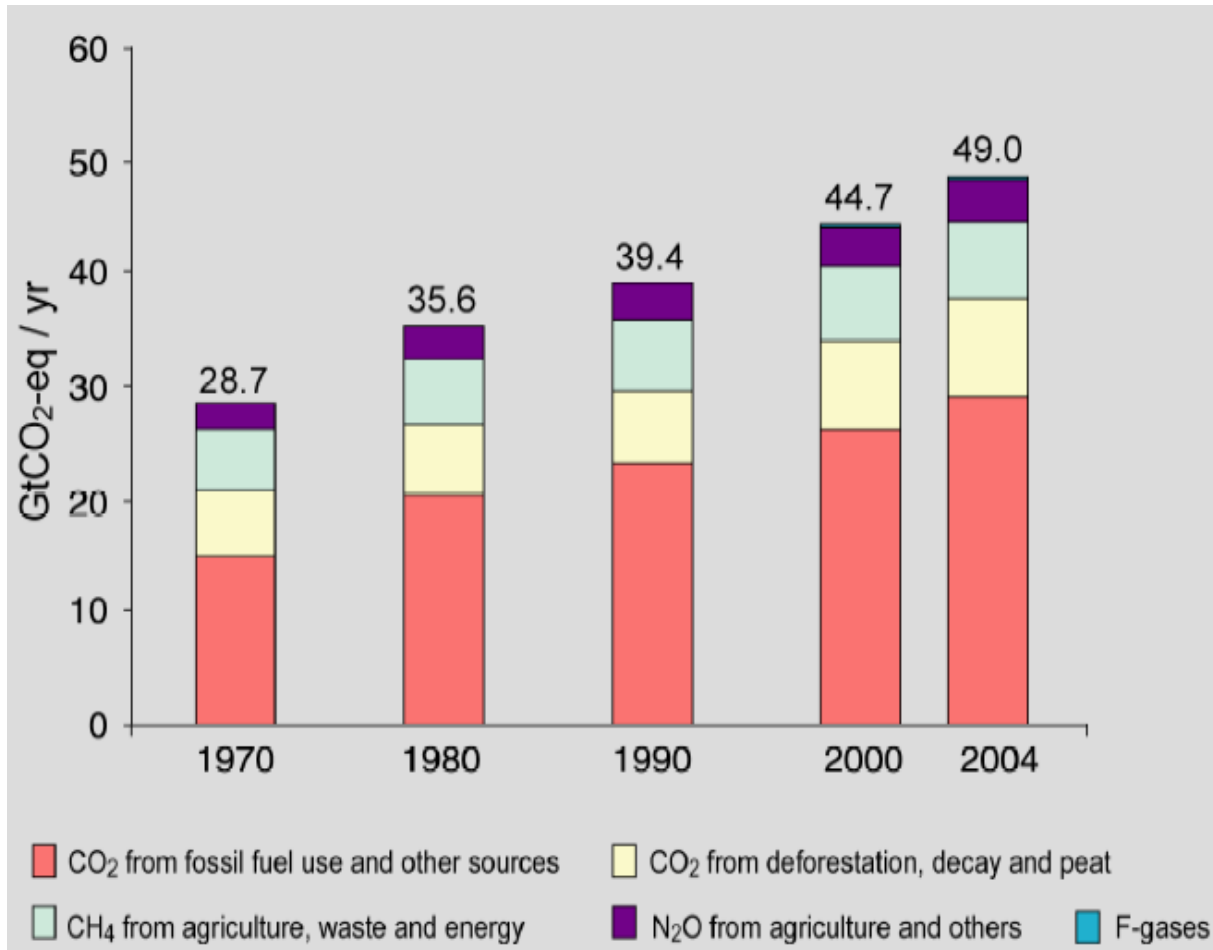

Measured data

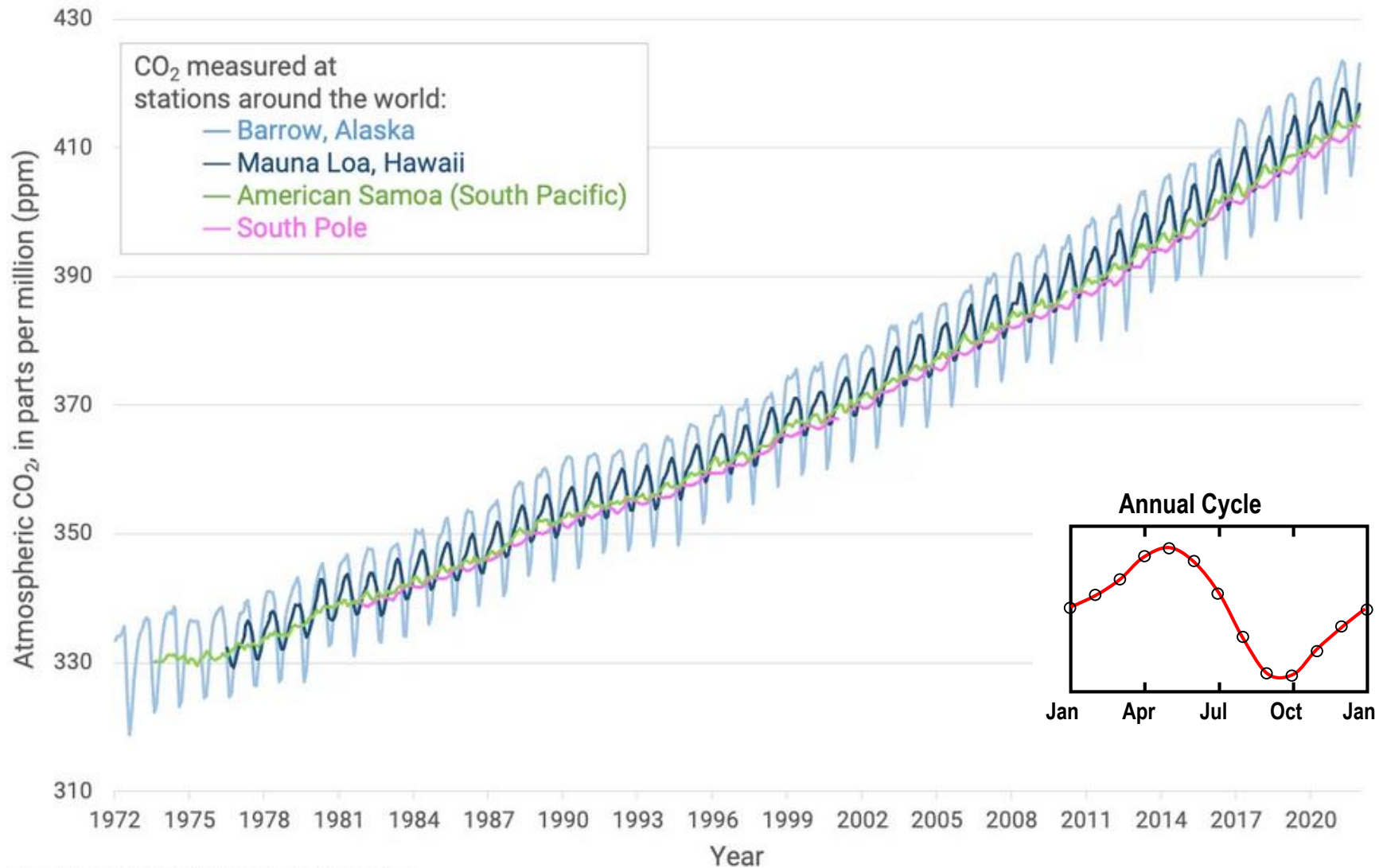

Data from NOAA Global Monitoring Laboratory
Monthly averages from flask samples

CLIMATE.NASA.GOV

CO₂ emissions per capita

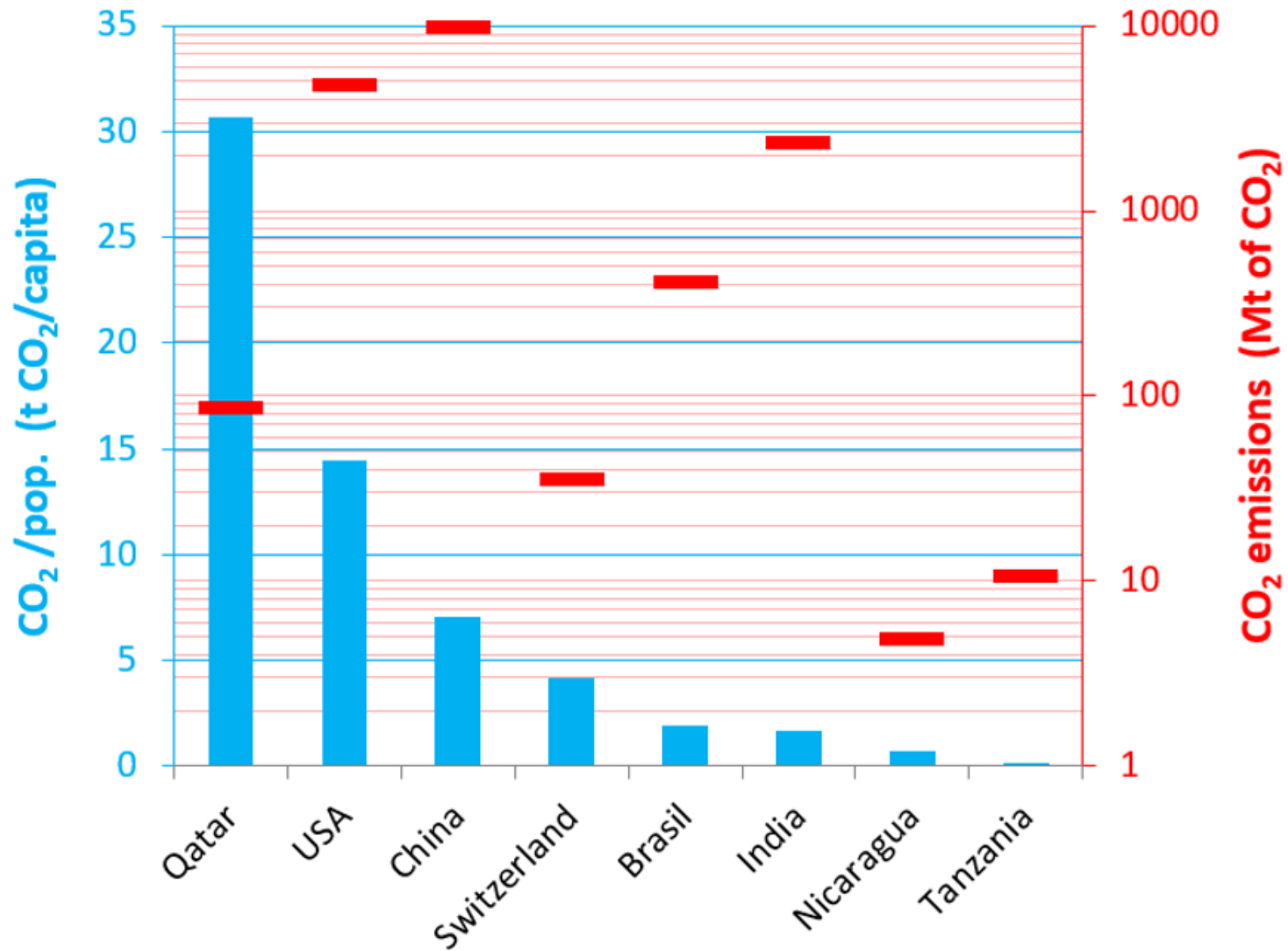

Carbon emissions, CO₂ conc. and temperatures variation

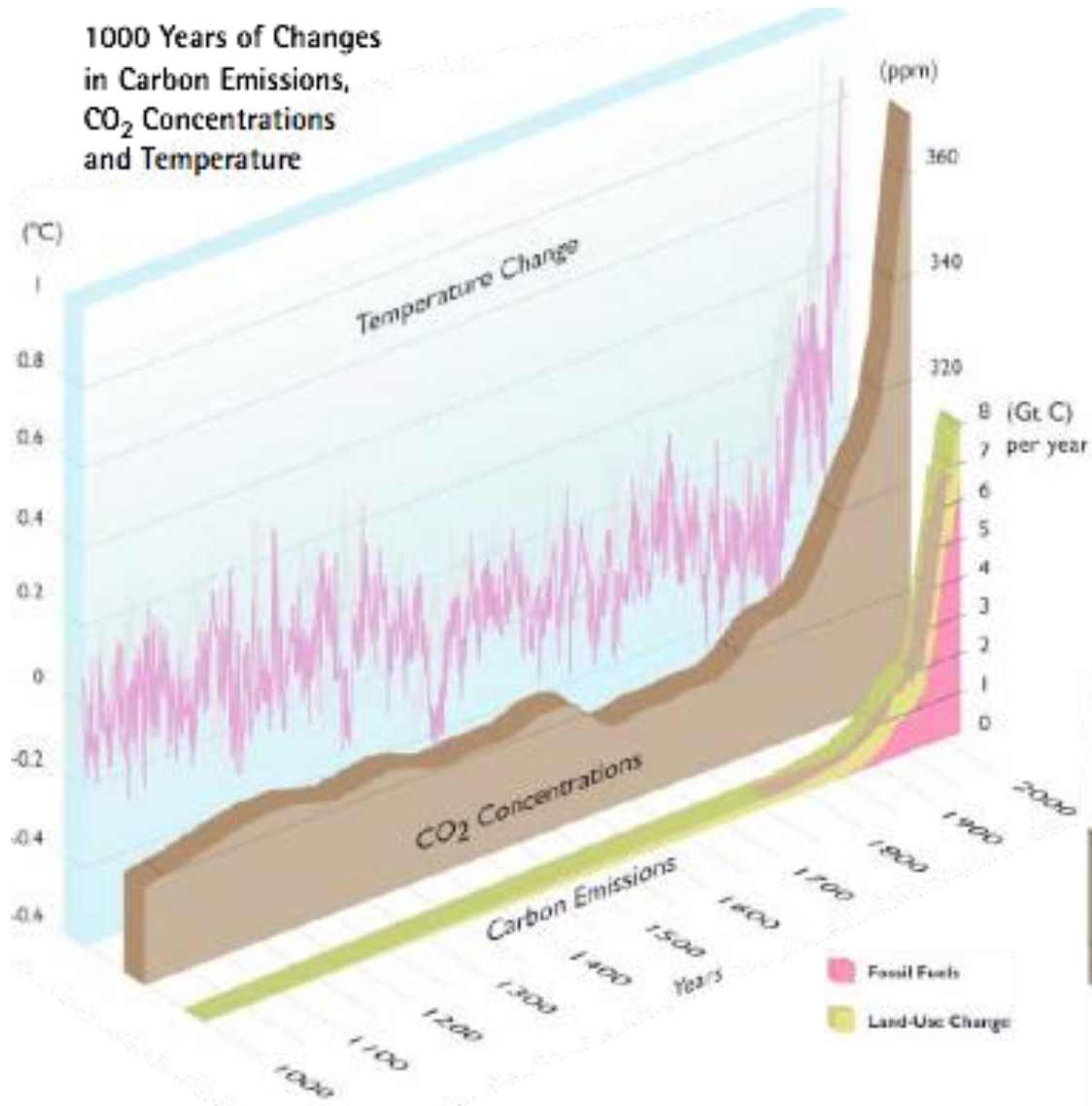

Hassol, 2004

Variation of the sea level (measured by satellite)

- Islands may disappear
- Inland saline water penetration underground



from Denhez,2005

Earlier grape collection!

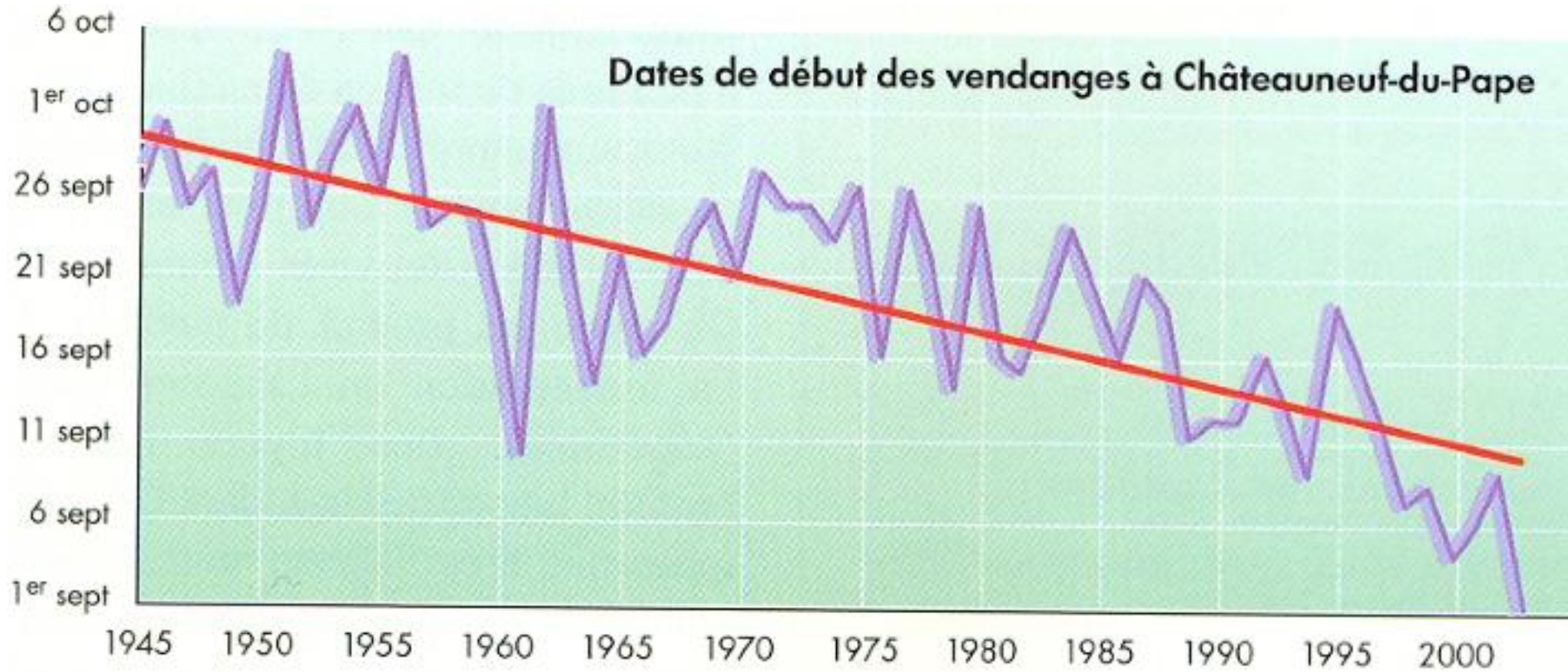

from
Denhez,2005

Source : B. Seguin, Labo INRA Avignon, CNRS, <http://www.cnrs.fr>.

Coal combustion and its impact (Pekin, winter, 2014)

Concentration PM2.5

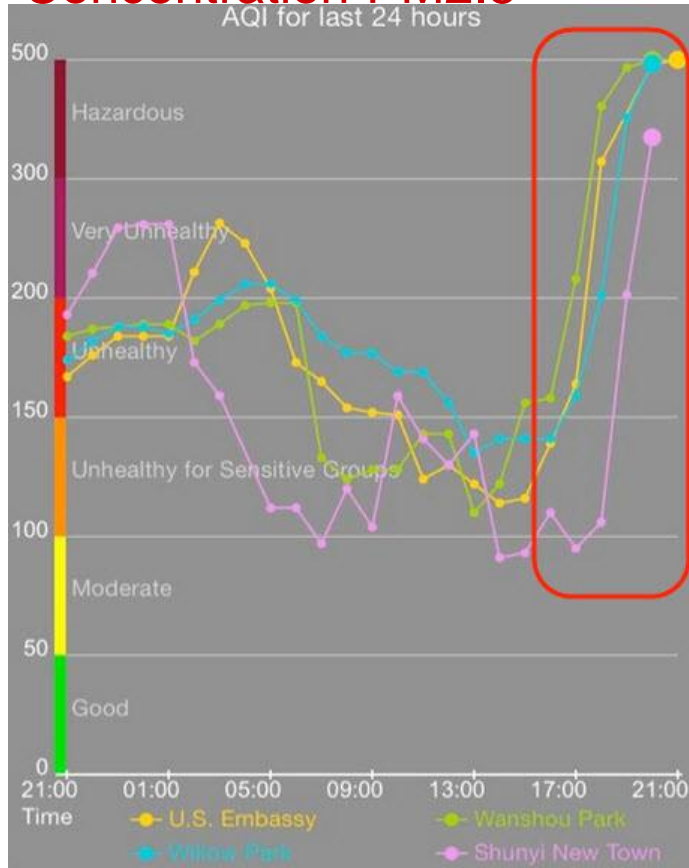

theguardian.com, Tuesday 25 February 2014 - *Chinese scientists have warned that the country's toxic air pollution is now so bad that it resembles a nuclear winter, slowing photosynthesis in plants – and potentially wreaking havoc on the country's food supply.*

Environmental impact

Marcellus field (US)

Land occupation
7-10 years of exploitation



Eau de Fracking

Waste mineralised water



Leakage in the aquifer



Leakage in the atmosphere

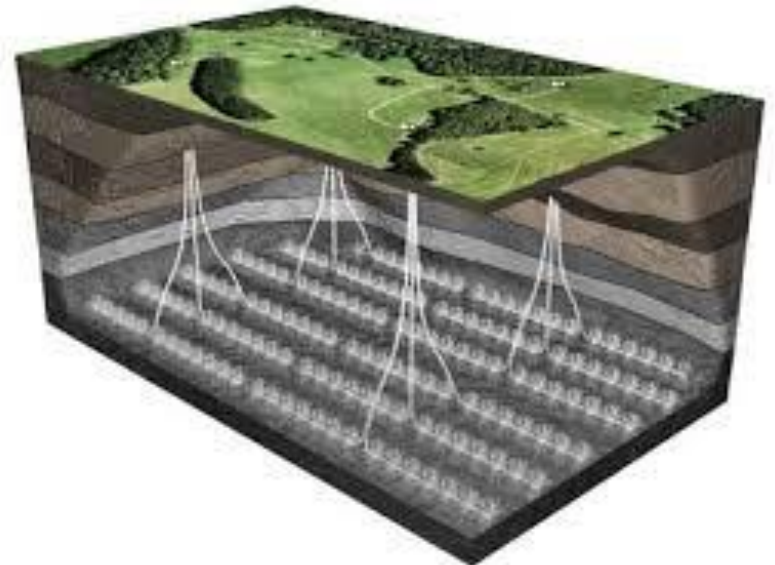

Under ground ? -> Earthquake

Environmental impact

- Importance of life cycle
 - Extraction
 - Treatment
 - Transport
 - Refinery
 - Distribution
 - Combustion

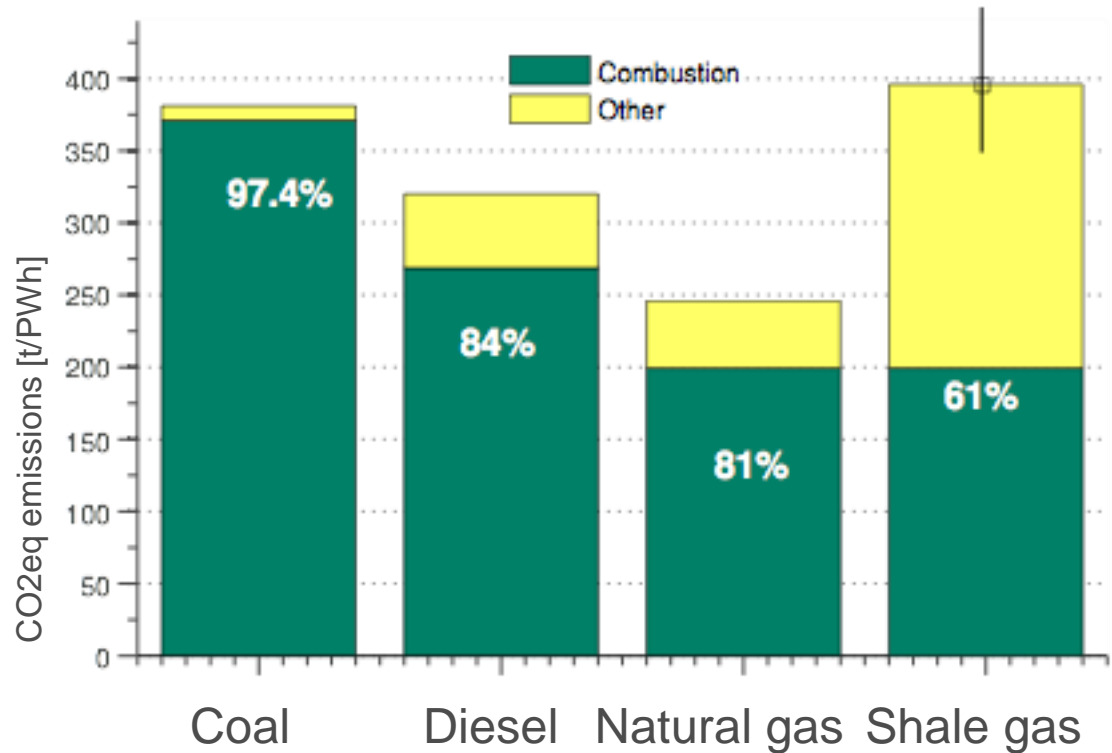

Geopolitical impacts (flows)

Major trade movements 2021

Trade flows worldwide (million tonnes)

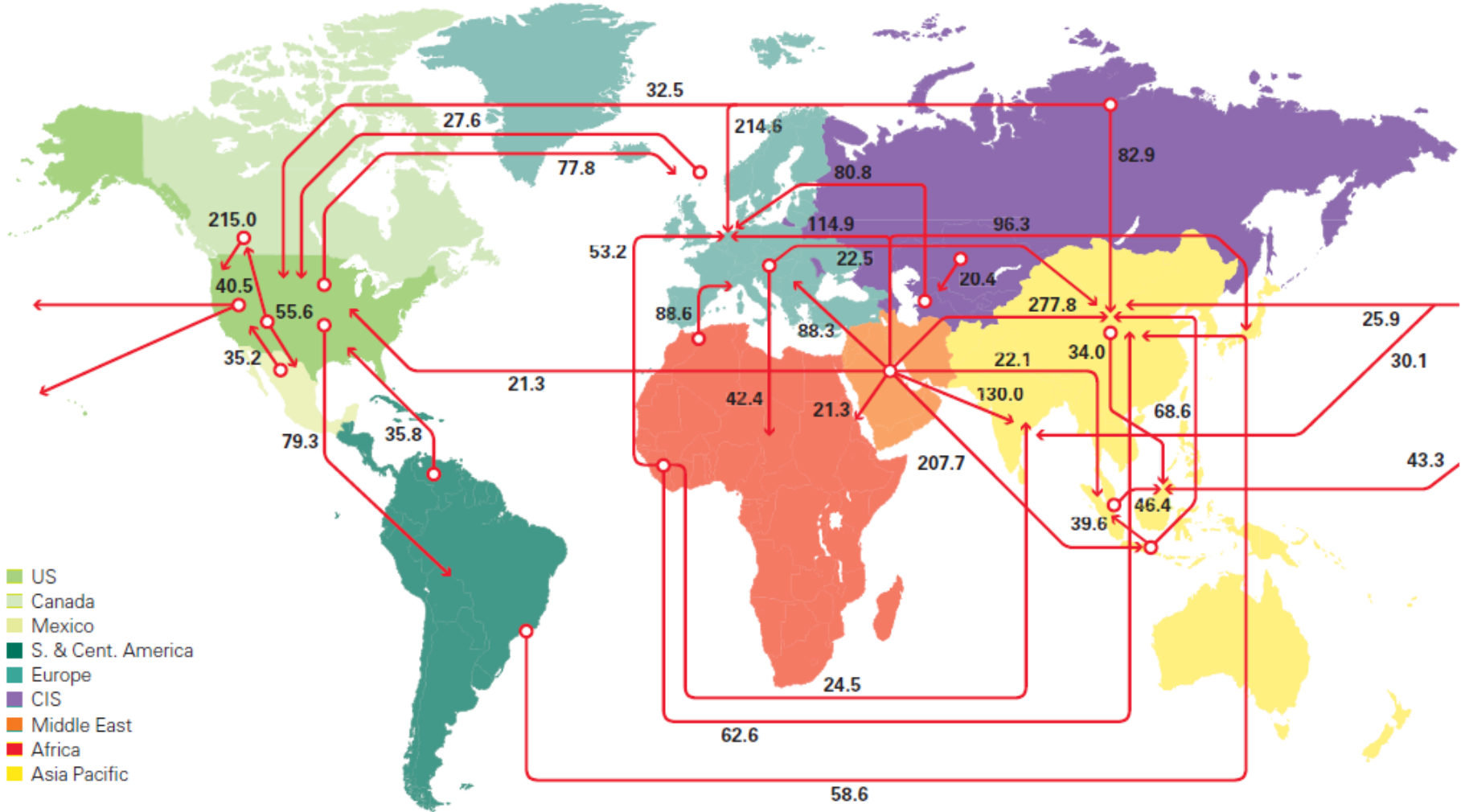

How to mitigate emissions and climate, while keeping the services

Sustainable development: meets needs of present without compromising ability of future generation

Sustainability

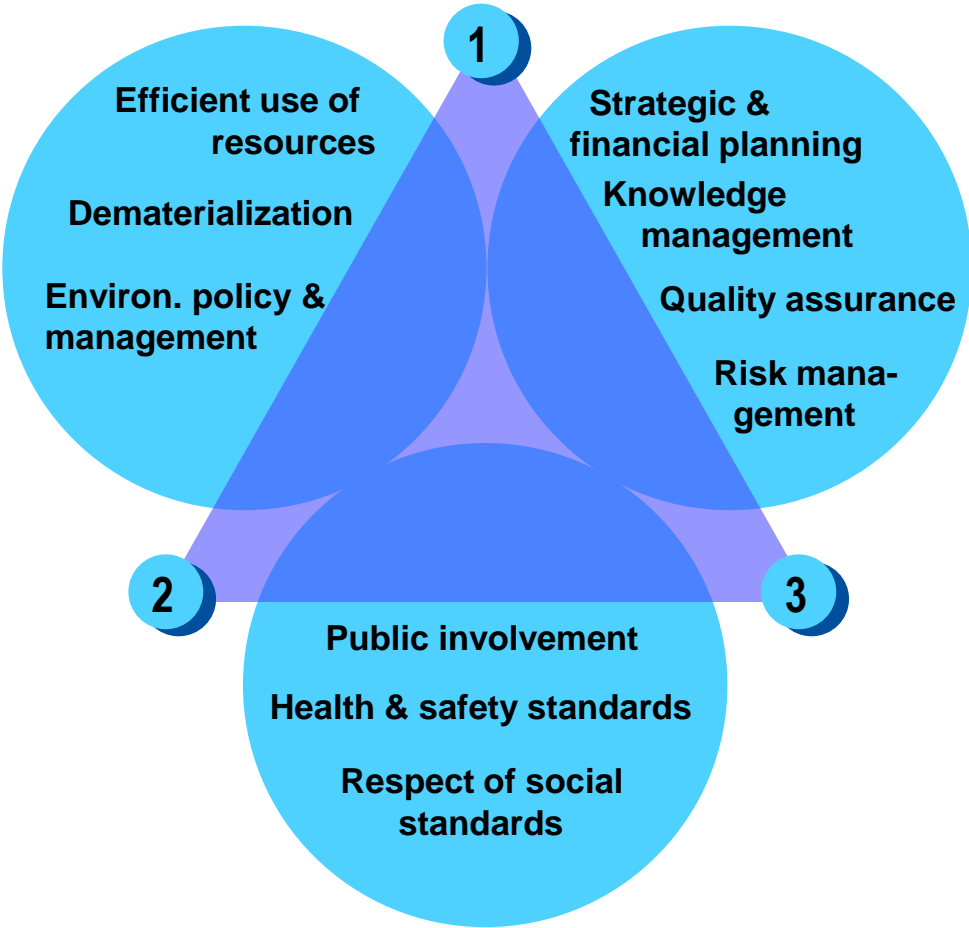

1 Economy

2 Environment

3 Society

→ Need for efficient, economical, renewable, and environmentally friendly energy technologies

Principal measures

1. Efficiency remains important
 - **ALL** technologies
 - Process integration and optimization
2. Decarbonization of energy services
3. Increase of renewable energy utilization
4. Electrification of services
5. Address the storage issue (seasonal; esp. for renewables)
6. Grids (development, management)
7. Consumer awareness; incentives

All are interconnected!

Pathways

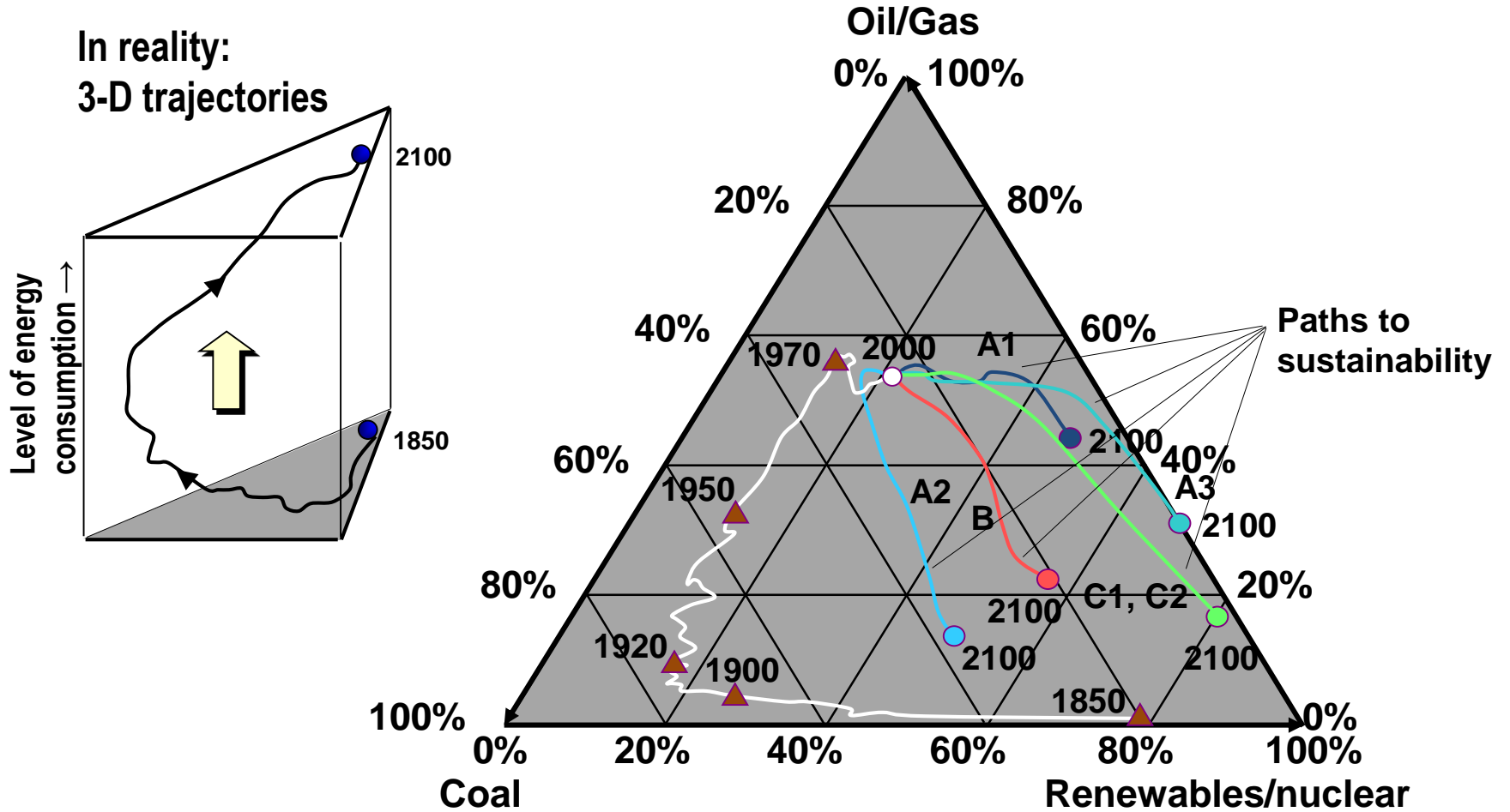

Summary

1. Energy supply is still strongly fossil fuel based
2. Economic fossil reserves suffice for ca. 100 yrs, but the climate issue is more urgent
3. Transition to a sustainable energy economy needed